

1LS-J700 SERIES ULTRA LONG LIFE, GENERAL-PURPOSE COMPACT LIMIT SWITCHES

With on-site mechanical life 3 times that of conventional models, improved reliability drastically reduces minor line interruptions.

- Mechanical life: at least 30 million operations.
- Improved sliding action and corrosion resistance prevents the actuator return failure.
- Wiring to the switch is by connector, to ensure a tight seal. (Conventional G1/2 conduit / switch terminal wiring type is also available.)
- At-a-glance fluorescent setting indication prevents faulty initial setup.
- UL/CSA-certified models available.



APPLICATIONS

- Automobile production facilities and related equipment
- Special-purpose machine tools
- Conveyors
- Automatic assembly machines
- General industrial machinery



CLICK

ORDER GUIDE

Actuator		Operating characteristics			Basic catalog listing *	Options			
		Max. O.F. (operating force)	Max. P.T. (pretravel)	Min. T.T. (total travel)		LED lamp With 12 to 125Vac-dc EC *	Double seal +LED SEC *	Connector +LED EC-PD	Preleaded connector +LED EC-PD03
Name	Shape								
Roller lever type		13.4N	Standard type 20°	Standard travel 50°	1LS-J700	1LS-J700EC	1LS-J700SEC	1LS-J700EC-PD	1LS-J700EC-PD03
			High sensitivity 5°	Standard travel 35°	1LS-J710	1LS-J710EC	1LS-J710SEC	1LS-J710EC-PD	1LS-J710EC-PD03
		8.9N	Standard type 20°	High overtravel 75°	1LS-J720	1LS-J720EC	1LS-J720SEC	1LS-J720EC-PD	—
			High sensitivity 10°	High overtravel 72°	1LS-J730	1LS-J730EC	1LS-J730SEC	1LS-J730EC-PD	1LS-J730EC-PD03

ULTRA LONG LIFE LIMIT SWITCHES

Here is what's different about the 1LS-J700Series

1. Breakdown of trouble in conventional limit switches

The following shows the results of investigation and analysis of the causes of trouble in products returned for repair to Yamatake from the field.

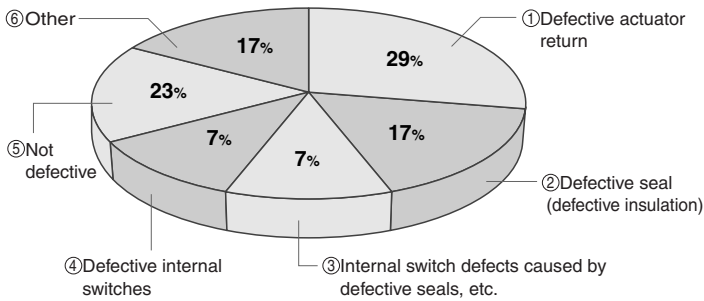

The ultra long life limit switch 1LS-J700Series adopts countermeasures for the following five of these causes:

- ① Defective actuator return
- ② Defective seal (defective insulation)
- ③ Internal switch defects caused by defective seals, etc.
- ④ Defective internal switches
- ⑤ Not defective (but setup was faulty, due often to low visibility of O.T. indicator)

These modifications have resulted in an ultra long life that could not be achieved with conventional limit switches.

2. Countermeasures

The following table summarizes the requirements related to the above causes, and outlines the countermeasures that have been adopted.

Cause of trouble	Requirements	Implemented countermeasures
① Defective actuator return	Improvement of sliding action of operating head components, improvement of corrosion resistance, improvement of lubricant quality and quantity.	Moving parts on the operating head were SUS-nitrided and treated with special coating. Specially coated O-ring was used. Lubricant was changed.
②・③ Defective seals	Improvement of seal around the shaft. Improvement of switch body cover and conduit seal.	Shaft seal was double-sealed (V-ring + O-ring). Terminal connections with open covers were eliminated, and an internal loaded connector was used.*2
④ Defective internal switches	Improvement of internal switch life.	Two internal moving springs were used.
⑤ Low visibility of O.T. indicator	Modification of setting indication function*1	The root of the shaft was capped with a rubber cap with indication slit, and fluorescent marking is visible through the slit.

Notes:

*1. Conventional limit switches are equipped with an operation pointer for indicating the appropriate O.T. (overtravel). However, as this pointer is difficult to see when actually setting operation, generally setting is performed by an operation indicator lamp. For this reason, a phenomenon occurs where there is little margin in the initial setup during mounting with respect to O.P. (operating position), and the switch does not turn ON even though the dog arrives at the switch operation position and presses the lever. As a result of investigating, we found that a large number of normal limit switches were returned for repair for this reason. As a countermeasure, the O.T. indication was changed to an easy-to-view fluorescent type.

*2. Conventional terminal connection type and G1/2 conduit types where the cover is opened for wiring to the switch terminal are also available.

3. Structure of Ultra Long Life Limit Switches

Overall switch

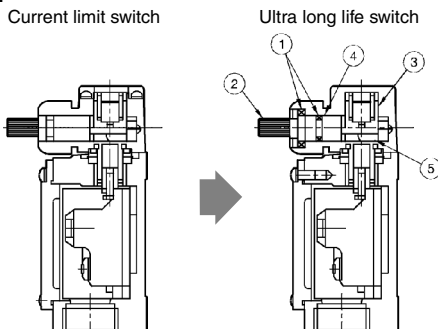

The slide-action and corrosion resistance of moving parts inside the operating head were improved.

- ① The seal of the moving head was improved by double-sealing the shaft with both V-ring and O-ring.
- ②③ Slide-action was improved and corrosion when immersed in water was prevented by treating the operating shaft and other moving parts with SUS nitriding and special coating.
- ④ Friction was reduced by a special coating on the shaft O-ring.
- ⑤ Lubricant with higher fluidity and better resistance to extreme pressure was used.

The life of the moving parts was lengthened by the above modifications.

●Setting indicator pointer

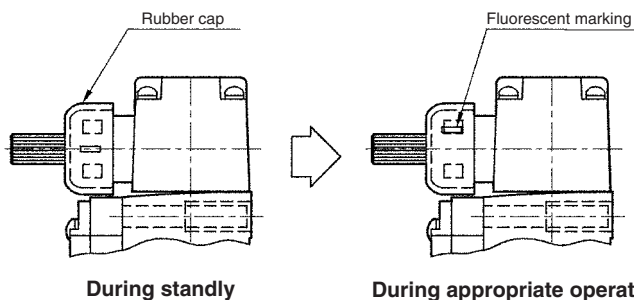

In this design, the shaft root is capped with a slitted black rubber cap. When the lever is flipped down and reaches the appropriate O.T. (overtravel), the fluorescent marking can be seen through the slit. This modification enables easy confirmation from a distance and facilitates initial setup.

4. Evaluation Results

Mechanical life was improved considerably, as seen below.

Estimated life under actual operating conditions		Results of proprietary accelerated mechanical life test	
		Minimum life	Lifespan at 3,000 operations/day
Current LS Example: 1LS1-J	Approx. 3 million operations	2 million operations	2 to 3 years
Ultra long life LS Example: 1LS-J700	Approx. 13 million operations	Min. 6 million operations	8 to 9 years

PERFORMANCE

Catalog listing		1LS-J70□	1LS-J71□	1LS-J72□	1LS-J73□	
External standards	Compliance	JIS C 4508, JIS C 8201-5-1				
	Certification	UL/CSA*1				
Structure	Contact form	2-circuit double break				
	Terminal type	M4 screw (switch terminal screw)				
	Contact type	Silver rivet				
	Protective structure	IP67(IEC529)				
Electrical performance	Electrical rating	See Table 1.				
	Dielectric strength	Between non-continuous terminals (same polarity): 1,000V, 50/60Hz for 1 minute Between each terminal and non-live metal part: 2,000V, 50/60Hz for 1 minute				
	Insulation resistance	Max. 100MΩ (by 500Vdc megger)				
	Initial contact resistance	Contact	Max. 50mΩ (6 to 8Vdc, thermal current 1A, voltage drop method)			
		Connector	Max. 40mΩ (excluding fixed resistance of cable, etc.)			
Recommended min. contact operating voltage/current	24Vdc 10mA					
Mechanical performance	Actuator strength	Withstands load 5 times O.F. (operating direction for 1 minute)				
	Impact resistance	300m/s ²	200m/s ²	300m/s ²		
		Contact opening for 1ms max. in free position and total travel position				
	Vibration resistance	1.5mm peak-to-peak amplitude, frequency 10 to 55Hz, for 2 continuous hours Contacts open for 1ms max. in free position and total travel position.				
	Allowable operating speed	1LS-J70□, 1LS-J72□, 1LS-J73□: 1.7mm/s to 0.5m/s (At min. speed, instability of contacts lasts 0.1s or less.) 1LS-J71□: 0.4mm/s to 0.5m/s (At max. speed, there is no actuator damage.)				
	Operating frequency	Max. 120 operations/minute				
Life	Cable pullout strength	Min. 100N				
	Mechanical life	Min. 30 million operations (at 1/3 to 2/3 of the rated overtravel)				
Ambient operating conditions	Electrical life	See Table 2.				
	Temperature	-10 to +70°C (freezing not allowed*2)				
Recommended tightening torque	Humidity	Max. 98% RH*3				
	Body	5 to 6N·m (M5 hexagon socket head bolt)				
	Cover	1.3 to 1.7N·m (M4 screw)				
	Head	0.8 to 1.2N·m (M3.5 screw)				
	Lever	4 to 5.2N·m (M5 screw)				
Terminal screw	1.3 to 1.7N·m (M4 binding head machine screw with toothed washer)					

Notes:

*1. Some models do not fall under this category.

*2. With the double seal type (S type), 0 to +70°C for 1LS-J71□, and -5 to +70°C for other models

*3. Max. 95% RH for connector and preloaded connector types

● Table 1. Electrical rating

Type of indicator lamp	None		12 to 125Vac/dc LED	
	Catalog listing	Electrical rating	Catalog listing	Electrical rating
Standard	1LS-J700 1LS-J720	125, 250, 480Vac 10A 125Vac 1/2HP 250Vac 1HP 125Vdc 0.8A 250Vdc 0.4A	1LS-J700EC 1LS-J720EC	125Vac 5A 125Vdc 0.8A
Standard with double seal	—	—	1LS-J700SEC 1LS-J720SEC	125Vac 5A 125Vdc 0.8A
High sensitivity	1LS-J710 1LS-J730	125, 250, 480Vac 10A 125Vac 1/2HP 250Vac 1HP 125Vdc 0.8A 250Vdc 0.4A	1LS-J710EC 1LS-J730EC	125Vac 5A
High sensitivity with double seal	—	—	1LS-J710SEC 1LS-J730SEC	125Vac 5A
DC connector and preleaded connector types	—	—	1LS-J7□0EC-PD 1LS-J7□0EC-PD03	30Vdc 3A

● Table 2. Electrical life

Internal switch	Load	Life	
Standard load type	Rated load	Min. 500,000 operations	125Vac 10mA, 30Vdc 10mA
Low current load type	Rated load	Min. 2 million operations	Min. 30 million operations

● Circuit diagram

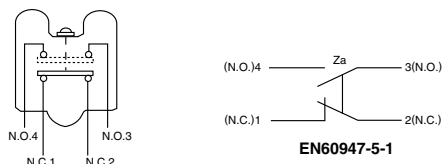

INDICATOR LAMP SPECIFICATIONS

Option	No indicator lamp	Neon lamp, 100/200Vac	AC-DC LED, 12 to 125V
Catalog listing	1LS-J7□□□	1LS-J7□□□E	1LS-J7□□□EC
Lamp cover front side	—		
Circuit diagrams			
Notes	—	To ensure lighting of the neon lamp, use 75Vac min.	The voltage indicator lamp (red LED) is 12 to 125V. The indicator lamp operates on either AC or DC power.
Lamp cover catalog listing (replacement part)	—	LS-29PA1	LS-29PAEC
Specifications	Operating voltage	100 to 200Vac	12 to 125V, AC or DC
		100Vac	200Vac
	Thermal current	Approx. 0.5mA	Approx. 1.5mA
Resistance	—	100kΩ	33kΩ

EXTERNAL DIMENSIONS

(unit: mm)

Basic dimensions

Without indicator lamp 1LS-J7□□□□

With indicator lamp 1LS-J7□□□□EC

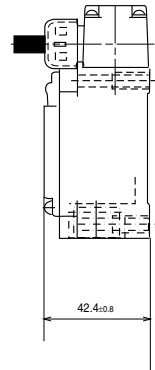
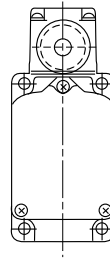
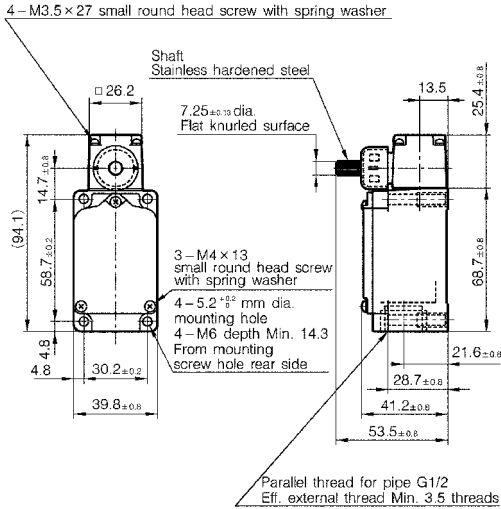

Actuator mounting dimensions and connector dimensions

Standard roller lever mounting connector (quick removal) type

Adjustable roller lever mounting preloaded connector type

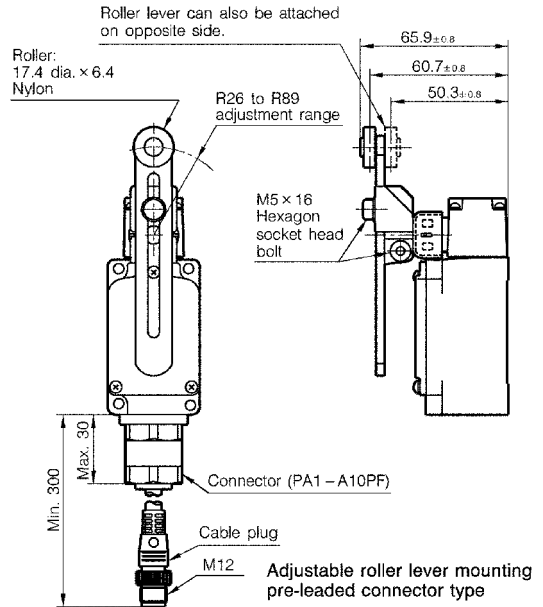
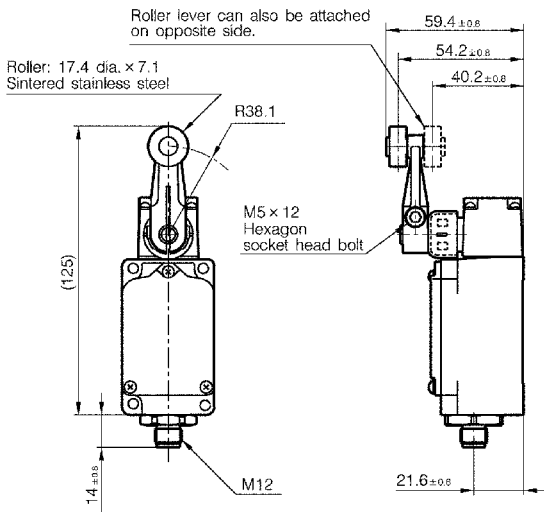

OPERATING CHARACTERISTICS

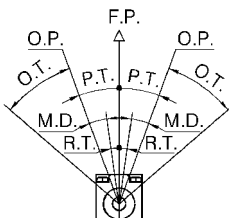

Catalog listing		1LS-J70□□□□ standard travel	1LS-J71□□□□ standard travel high	1LS-J72□□□□ high overtravel	1LS-J73□□□□ high overtravel high
Characteristics		general characteristics	sensitivity characteristics	general characteristics	sensitivity characteristics
Operating characteristics*	O.F. (operating force) max.	13.4N	13.4N	8.9 N	8.9 N
	R.F. (release force) min.	2.2N	2.2N	0.98N	0.98N
	P.T. (pretravel)	Max. 20°	5 ⁺² ₀	Max. 20°	10 ⁺³ ₀
	M.D. (movement differential) max.	12°	3°	12°	5°
	O.T. (overtravel) min.	30°	30°	55°	62°
R.T. (return operation)	Min. 5°	—	Min. 5°	—	
Pointer position angle		25° to 45°	16° to 36°	25° to 45°	16° to 36°

*Operating characteristics, O.F. and R.F. values were obtained at a standard roller lever length of 38.1mm.

ABOUT OPERATION SETTINGS

There is a slit window in the rubber cap mounted on the operation shaft. When the shaft rotates and reaches the appropriate operation range, a fluorescent marking appears in this window to indicate that the switch is in a stable operating position.

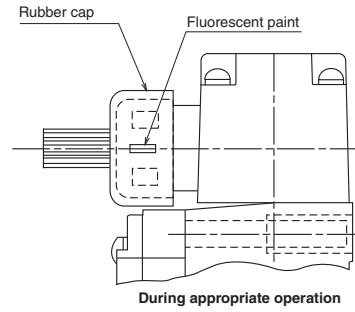

CONNECTOR PIN LAYOUT

1LS-J7□□□□-P□□

Catalog listing codes	Pin layout	Circuit diagrams		Note (applies only to models with indicator lamp)
		Without indicator lamp	With indicator lamp EC	
PD PD03				<p>The switch is assembled so that lamps light when the actuator is in the FREE position. The lamps can be made to light in the PUSH position by attaching the bracket on the rear side of the cover in the opposite direction.</p>

●4-lead type

Connector		Internal switch
Contact No.	Lead color	Terminal No.
1	Red	No.1
2	Green	No.2
3	Black	No.3
4	White	No.4

The contact assignments of limit switches comply with Nippon Electric Control Equipment Industries Association standards (NECA 4202).

CABLE WITH CONNECTOR

Be sure to use PA5 Series cables with connector to connect preleaded type connectors and connector type limit switches.

PA5 Series cable with connector

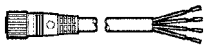
Shape	Power supply	Cable properties	Cable length	Catalog listing	Lead colors
	DC	Oil-resistant, flexible; UL2464; flame-resistant; EN-compliant	2m	PA5-4ISX2MK-E	1: brown, 2: white, 3: blue, 4: black
			5m	PA5-4ISX5MK-E	1: brown, 2: white, 3: blue, 4: black
	AC		2m	PA5-4JSX2MK-E	1: brown, 2: white, 3: blue, 4: black
			5m	PA5-4JSX5MK-E	1: brown, 2: white, 3: blue, 4: black

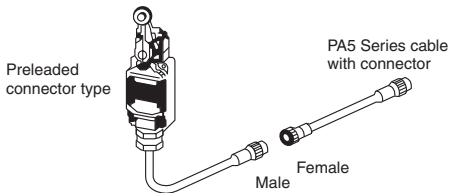



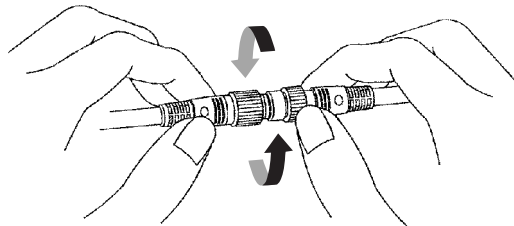

Tightening the connector

Align the grooves and rotate the fastening nut on the PA5 connector by hand until it fits tightly with the connector on the limit switch side.

limit switch side PA5 side



For AC		For DC	
Switch side (male)	Connector side (female)	Switch side (male)	Connector side (female)
			

※ The shape of the connector plugs and sockets is different for AC and DC cables, which are not mutually compatible.

CONNECTOR SPECIFICATIONS*1

Item	Specification details	
Operating voltage/current	For AC: min. 5V 5mA, max. 250V 3A For DC: min. 5V 5mA, max. 125V 3A	
Insulation resistance	Max. 100MΩ (by 500Vdc megger)	
Dielectric strength	1,500Vac for 1 minute (between contacts, and between contact and connector housing)	
Initial contact resistance	Max. 40mΩ (with 3A current to connected male and female connectors. Semiconductor lead-specific resistance not included.)	
Mating/unmating force	0.4 to 4.0 N per contact	
Mating cycles	50	
Connector nut tightening torque	Min. 0.8N·m *2	
Cable pullout strength	Min. 100 N	
Vibration resistance	10 to 55Hz, 1.5mm peak-to-peak amplitude, for 2 hours each in X, Y and Z directions	
Impact resistance	300m/s ² , 3 times each in X, Y and Z directions	
Protective structure	IP67	
Ambient operating temperature	-10 to +70°C	
Ambient storage temperature	-20 to +80°C	
Ambient operating humidity	Max. 95% RH	
Material	Contacts	Gold-plated brass
	Contact holder	Glass-lined polyester resin
	Housing	Polyester elastomer
	Coupling	Brass (DC type: Ni-plated. AC type: orange-colored)
	O-ring	NBR

*1. Specifications assume the use of a Yamatake connector (PA5 Series).

*2. The recommended tightening torque is 0.4 to 0.6N·m. If the connector is not tightened firmly, IP67 protection may be lost, or the connector may come loose. Tighten firmly by hand.

PRECAUTIONS FOR USE

1. Connecting switches that have indicator lamps

1.1 Series connection

Up to six switches can be connected in series when the power is 100V. The brightness of the LED lamp is fixed regardless of the power, since light is generated by a built-in fixed-current diode.

1.2 PC connection possible

The leakage current when the limit switch is not operating is a maximum of 0.6mA. The PC will not malfunction due to dim lighting of the LED. Moreover, a fixed-current diode is built in to ensure a fixed LED brightness regardless of the power voltage.

2. Handling of connector and preleaded connector switches

2.1 Tightening the fixing cap ring and outside screw lock ring

If the screw of the mating part is made of resin, the threads can easily be damaged when the connector is first tightened. When assembling the connector, align the center of the cores, push in as far as possible, and then turn to tighten.

Be sure to tighten fully by hand. The recommended tightening torque is 0.4 to 0.6N·m. Use of a tightening tool may damage the connector. If the connector is not tightened firmly, IP67 protection may be lost, or the connector may come loose.

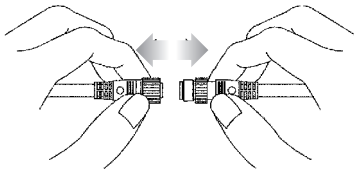

2.2 Inserting and removing connectors

Before inserting or removing connectors, be sure to turn the power OFF. When removing, hold the connector itself—do not pull by the cable.

2.3 Cautions when bending cables

The minimum bend radius (R) of the cable is 80mm. Allow sufficient cable for bends.

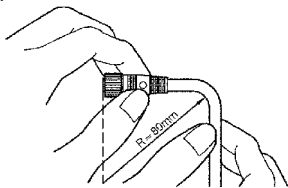

2.4 Installation of connector type switches

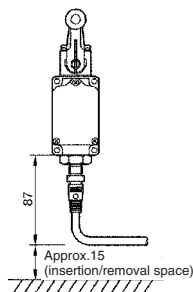

(unit: mm)

2.5 Cautions when replacing connectors

When removing connectors to replace the switch or cable, wipe the connector and the surrounding area thoroughly to remove any water.

After removing the connector, do not allow it to be immersed in chemicals or powder, or to be dropped. If the connector is immersed in a fluid, allow it to fully dry before connecting again. If the connector is dropped in powder, wipe it off completely before connecting again. Failure to observe these precautions may result in a short circuit or a failed connection.

3. Other

3.1 Protective structure

- IP67 protection does not assure complete waterproofing. Switch should not be in constant contact with water.
- Avoid use where external force is applied at all times on the connecting section of the connector.
- Do not use the body as a step or place heavy objects on top of it.

3.2 Ensuring a good seal

- When general-purpose limit switches are used in locations subject to splashing by water, oil, dirt and dust, or chips, water or oil sometimes enters the switch from the conduit due to capillary action. For this reason, be sure to use a sealed connector compatible with the cable.
- When the screws in the head or covers are loosened to change the operating direction of the switch, or the relationship between switch operation and the indicator lamp (lamp ON during switch standby / during switch operation), tighten the screws to the recommended tightening torque to ensure a good seal.

<Recommended tightening torque>

Cover: 1.3 to 1.7N·m (M4 screw)

Head: 0.8 to 1.2N·m (M3.5 screw)

3.3 Attaching switches

- Tighten each of the parts on the limit switch according to the appropriate tightening torques listed in the performance tables. Overtightening damages screws and other parts. On the other hand, insufficient tightening of screws lowers the effectiveness of the seal and reduces various performance characteristics.
- Do not leave or use covers and conduit parts open. Water, dirt, or dust may enter, which causing malfunction.
- Prevent impact to the lever body and head. Failure to do so might deform the actuator or cause defective switch return.
- Do not use silicone rubber electrical lead insulation, silicone adhesive or grease containing silicone. Doing so might result in defective electrical conductivity.

3.4 Wiring

- Do not perform wiring with the power ON. Doing so might cause electric shock, or the machine may start unexpectedly, causing an accident.
- Use crimp-type terminal lugs with covered insulation for electrical leads to prevent contact with covers and housings. If a crimp-type terminal lug contacts a cover, the cover may no longer shut or a ground fault may occur.
- Use sealed connectors (PA1 Series, etc. sold separately) or flexible tubing (PA3 Series) with IP67 or equivalent seal for conduits.
- Firmly tighten covers and conduits. If covers and conduits are not sufficiently tightened, the seal will be impaired and switch performance will no longer be assured.

3.5 Adjusting switches

- Do not apply excessive force (5 times O.F.) to the actuator beyond the total travel position. Doing so might damage the switch.
- Keep overtravel between 1/3 to 2/3 of the rated value. Small overtravel might cause the contacts to rattle due to vibration and impact, or may result in defective contact.