

DC 2-wire Thin Proximity Sensors

FL2F Series

This DC 2-wire Type Compact Proximity Sensor Takes up Little Mounting Space and can be Directly Connected to Programmable Controllers and N.C. Units.

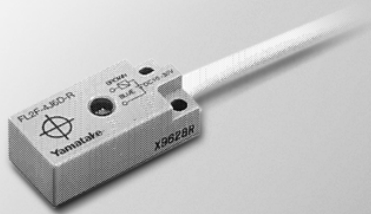

- Reduced wiring costs
- Stable sensing area displayed by setting indicator (on N.O. output type only)
- High-speed response (1.5kHz)
- High seal capabilities (IP67)
- Enhanced circuit protection (surge absorption, load short-circuit, reverseconnection)



CLICK

ORDER GUIDE

- Standard (pre-leaded) model (cord length 1m)

Actuation method	Appearance		Sensing distance	Sensing face	Operation mode	Setting indication	Catalog listing
	Sensor package style	Dimensions					
High-frequency oscillating type (unshielded)		15 × 10 × 32	4mm	Side	N.O.	○	FL2F-4J6D-R
					N.C.	—	FL2F-4K6-R

SPECIFICATIONS

Item	Catalog listing	FL2F-4□□6□-R
Actuation method		High-frequency oscillating type (unshielded)
Rated supply voltage		12/24Vdc
Rated sensing distance		4 ± 0.4mm
Usable setting distance		0 to 3.2mm
Standard target object		18 × 18mm, 1mm thick iron
Differential travel		15% max. of sensing distance
Operating voltage range		10 to 30Vdc
Leakage current		1mA max.
Control output		Switching current: 4 to 100mA max., voltage drop: 3.3V max., Output, dielectric strength: 30Vdc
Response frequency		1.5kHz
Hysteresis		0.05mm max.
Temperature characteristics		± 10% max. for the range of -25 to +70°C when +25°C is taken as standard, temperature in sensing distance
Supply voltage characteristics		± 1% max. with ± 15% voltage fluctuation with rated supply voltage as standard voltage in sensing distance
Indicator lamps		N.O. type: Operation indication: Lights (red or green) at output Setting indication: Lights (green) in stable sensing area N.C. type: Operation indication: Goes out (red) in sensing area
Operating temperature range		-25 to +70°C
Storage temperature range		-25 to +70°C
Storage humidity range		35 to 95% RH
Insulation resistance		50MΩ min. (by 500Vac megger)
Dielectric strength		500Vac, 50/60Hz for 1 minute
Vibration resistance		10 to 55Hz, 1.5mm peak-to-peak amplitude, 2 hrs in X, Y and Z directions
Shock resistance		490m/s ² 10 times in X, Y and Z directions
Protection		IP67 (IEC standard)
Weight		Approx. 40g
Circuit protection		Surge absorption, load short-circuit protection, reverse connection protection
Wiring method		Pre-leaded
Case material		ABS resin

ABOUT SETTING INDICATION

The proximity sensor can detect objects reliably by bringing the proximity sensor close to the target object and setting the sensor at the position where the indicator lamp changes from red to green.

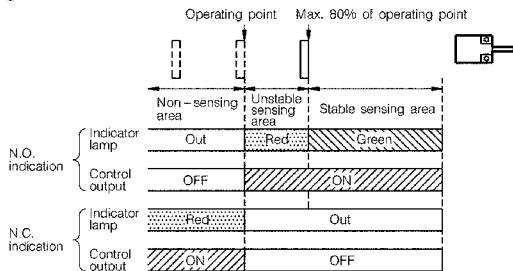

Note:

When the target object is made of a different material such as aluminum, copper and stainless steel to the standard target object (iron), the setup point where the indicator lamp changes color is shorter than 80% maximum.

WIRING DIAGRAM

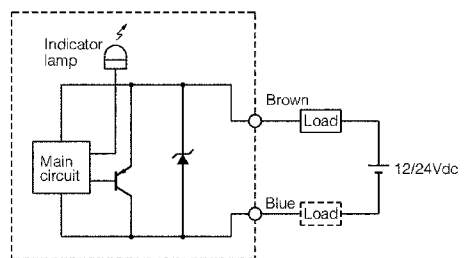

The load can be connected to either of the power supplies.

SENSING AREA DIAGRAM (typical example)

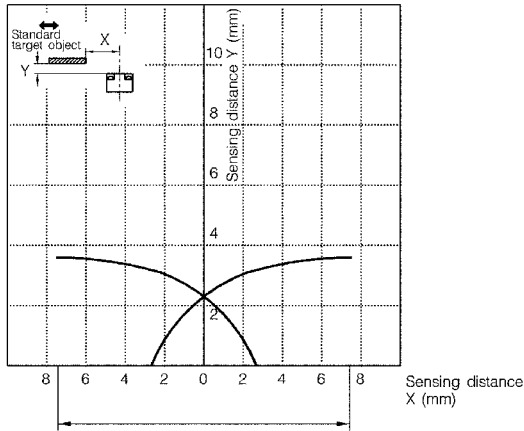

SENSING DISTANCE ACCORDING TO MATERIAL & SIZE OF OBJECT (typical example)

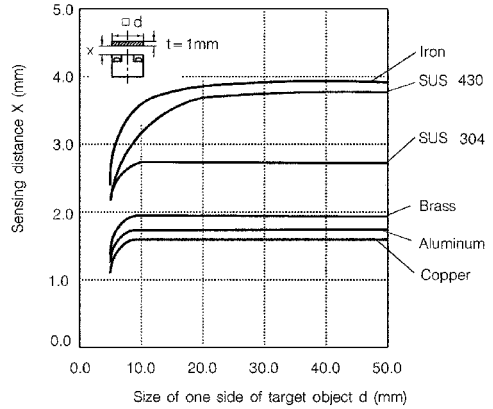

VOLTAGE DROP CHARACTERISTICS (typical example)

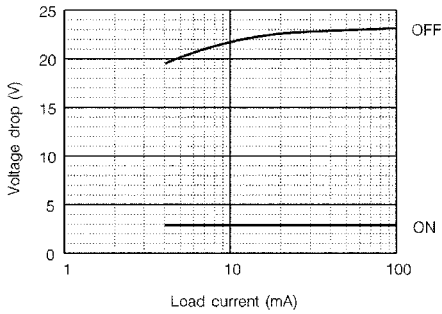

LEAKAGE CURRENT CHARACTERISTICS (typical example)

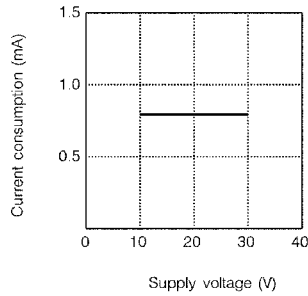

EXTERNAL DIMENSIONS

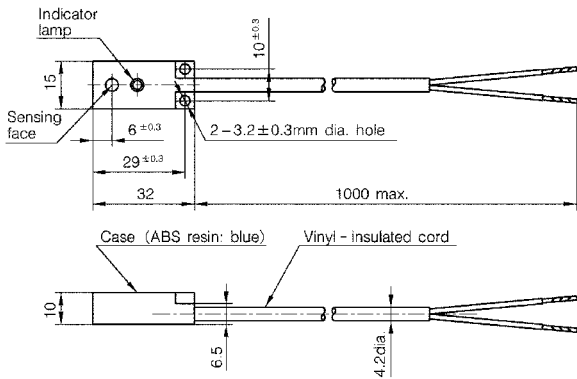

Vinyl-insulated cord (oil-resistant, bend-resistant type: 0.3mm², 60/0.08, 2-core) 4.2mm dia.

PRECAUTIONS

● Mounting

Tighten the screws to the torque shown below.

Catalog listing	Allowable tightening torque (N·m)	Recommended screw diameter
FL2F-4□6□-R	0.5	M3

● Influence of surrounding metal

Metal other than the object surrounding the sensor may influence operating characteristics. Maintain the following space between the sensor and surrounding metal.

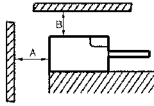

Note:
Shaded areas indicate surrounding metal other than the target object.

Catalog listing	A (mm)	B (mm)
FL2F-4□6□-R	10	20

● Mutual interference prevention

When mounting proximity sensors in parallel or facing each other, mutual interference may cause the sensor to malfunction. Maintain at least the spaces indicated in the figures above.

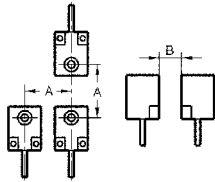

Catalog listing	A (mm)	B (mm)
FL2F-4□6□-R	30	40

● Cautions during series or parallel connection

(1) Series connection (AND connection)

- When connecting two or more proximity sensors in series, erroneous output (1 to 3ms) may occur without the rated current being supplied to each of the sensors. For this reason, series connection of proximity sensors is not recommended. However, if proximity sensors must be connected in series, a resistor of 10kΩ must be provided in parallel to each of the sensors. However, note that the maximum leakage current in a series connection will be 3.5mA.

Operation lag also will occur, resulting in increased voltage drop, and the operation indicator lamp will not light.

Operation lag = 40ms × (number of series connections - 1)

Voltage drop = voltage drop of single sensor × number of series connected sensors

(2) Parallel connection (OR connection)

- When connecting two or more proximity sensors in parallel, leakage current increases as follows, and may result in faulty load restore.

(Leakage current = Leakage current of single sensor × number of series connected sensors)

- When two or more sensors turn ON in a parallel connection, one (or some) of the sensors may not indicate operation. This is not an abnormality.

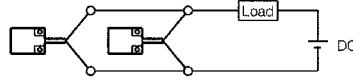

● Relay loads

The voltage drop of the FL2F Series is 3.3V. Pay attention to this voltage drop when using a relay load. (With 12Vdc relays, switching is not possible.)

● Operation at power ON

After the power is turned ON, it takes 40ms or less until the proximity sensor is ready for sensing.

When the load and the proximity sensor use different power supplies, be sure to turn the proximity sensor ON before turning the load ON.

● Influence of leakage current

Minimal current flows as leakage current for operating the circuits even when the proximity sensor is OFF.

Take sufficient care when restoring connected loads.

● Minimum cord bending radius (R)

The minimum bending radius (R) of the cord is 3 times cord diameter, take care not to excessively bend the cord beyond this radius. Also, do not excessively bend the cord within 30mm of the cord lead-in port.