

# DC 2-Wire Cylindrical Long-Distance No-Polarity Proximity Sensors C

## FL7M Series

Rigid structure reduces damage from collision with workpiece.

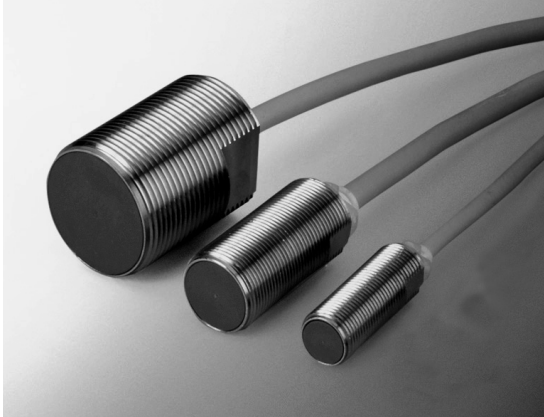

- Long sensing distance  
(M12: 4mm, M18: 8mm, M30: 15mm)
- DC 2-wire sensor with no polarity reduces wiring costs and wiring errors
- Stable sensing area is shown by the setting indicator
- Rigid housing allows higher mounting torque
- Firefly glow indicator can be seen from any direction
- Lowest current consumption in the industry: 0.55mA
- Sealed to IP67G





CLICK

### ORDER GUIDE

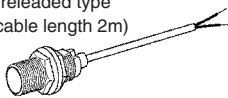
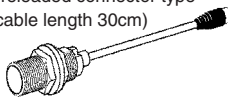
#### ● Main unit

Exterior		Sensing distance	Operation mode	Setting indicator	Oil-resistant cable	Catalog listing
Appearance	Size(O.D.)					
Firefly indicator Preleaded type (cable length 2m) 	M12	4mm	N.O.	●	●	FL7M-4W6
			N.C.		●	FL7M-4Y6
	M18	8mm	N.O.	●	●	FL7M-8W6
			N.C.		●	FL7M-8Y6
	M30	15mm	N.O.	●	●	FL7M-15W6
			N.C.		●	FL7M-15Y6
Firefly indicator Preleaded connector type (cable length 30cm) 	M12	4mm	N.O.	●	●	FL7M-4W6-CN03
			N.C.		●	FL7M-4Y6-CN03
	M18	8mm	N.O.	●	●	FL7M-8W6-CN03
			N.C.		●	FL7M-8Y6-CN03
	M30	15mm	N.O.	●	●	FL7M-15W6-CN03
			N.C.		●	FL7M-15Y6-CN03

● Accessories (sold separately)

Name	Appearance	O.D.	Catalog listing
Mounting bracket		For M12	<b>FL-PA112</b>
		For M18	<b>FL-PA118</b>
		For M30	<b>FL-PA130</b>
Protective cover		For M12	<b>FL-PA12</b>
		For M18	<b>FL-PA18</b>
		For M30	<b>FL-PA30</b>
Spatter-guarded protective cover		For M8	<b>FL-PA08W</b>
		For M12	<b>FL-PA12W</b>
		For M18	<b>FL-PA18W</b>
		For M30	<b>FL-PA30W</b>

## SPECIFICATIONS

Catalog listing	FL7M-4□6	FL7M-8□6	FL7M-15□6
Actuation method	High-frequency oscillation (shielded)		
Rated sensing distance	4 ±0.4mm	8 ±0.8mm	15 ±1.5mm
Usable sensing distance	0 to 3.2mm	0 to 6.4mm	0 to 12mm
Standard target object	12 x 12mm, 1mm thick iron	18 x 18mm, 1mm thick iron	30 x 30mm, 1mm thick iron
Differential travel	15% max. of sensing distance		
Rated supply voltage	12/24Vdc		
Operating voltage range	10 to 30Vdc		
Leakage current	0.55mA max.		
Output operational mode	DC 2-wire, transistor output		
Control output	Switching current 3 to 100mA, voltage drop 5.0V max. (with 100mA switching current, 2m cable), output dielectric strength 30Vdc		
Operating frequency	1,000Hz	500Hz	300Hz
Temperature drift	±10% of sensing distance max. for the -25 to +70°C range, taking +25°C as standard temp.		
Supply voltage drift	±1% of sensing distance max. with 15% voltage fluctuation, taking rated supply voltage as standard voltage		
Indicator lamps	N.O. type: Operation indication: lights up (orange or green) when output ON Setting indication: lights up (green) in stable sensing area N.C. type: Operation indication: orange light goes out in sensing area		
Operating temperature	-25 to +70°C		
Storage temperature	-40 to +80°C		
Insulation resistance	50MΩmin. (by 500Vdc megger)		
Dielectric strength	1,000Vac, 50/60Hz for 1 minute		
Vibration resistance	10 to 55Hz, 1.5mm peak-to-peak amplitude, 2 hrs each in X, Y and Z directions		
Shock resistance	980m/s <sup>2</sup> 10 times each in X, Y and Z directions		
Protective structure	IP67 (IEC standard), IP67G (JEM standard)		
Weight (preleaded type)	Approx. 60g	Approx. 130g	Approx. 230g
Circuit protection	Surge absorption, load short-circuit protection, reverse connection protection circuit		
Wiring method	preleaded, Preleaded connector		
Material	Sensor	Ni-plated brass	
	Case	PBT	
	Sensing face	Nylon	
	Bushing	Elastomer	
	Cable protector	Polyester elastomer	
	Connector	Housing	Glass-lined polyester resin
	Holder	Gold-plated brass	
	Contacts		

## USING THE SETTING INDICATOR

The proximity sensor can be set up to detect objects reliably by bringing the sensor progressively closer to the target object and installing the sensor at the point where the indicator lamp (N.O. indication) changes from red to green.

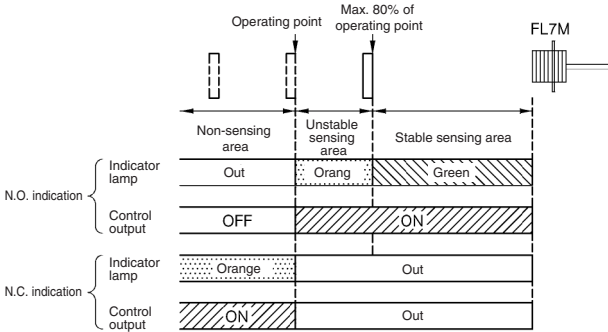

\*When the target object is made of different material (such as aluminum, copper or stainless steel) from the standard target object (iron), the distance at which the indicator lamp changes color is shorter than the 80% maximum.

## SENSING AREA (typical)

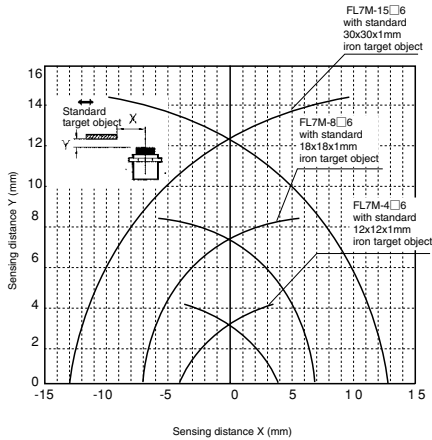

## SENSING DISTANCE ACCORDING TO MATERIAL AND SIZE OF OBJECT (typical)

FL7M-4□6

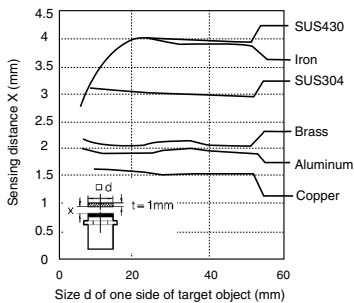

FL7M-8□6

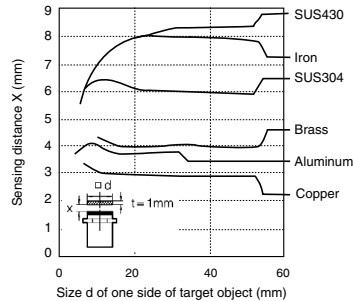

FL7M-15□6

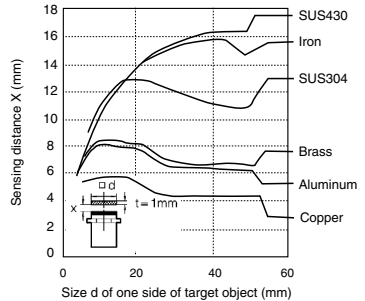

## VOLTAGE DROP (typical)

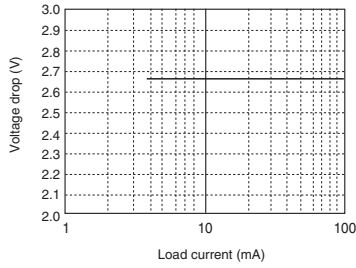

## LEAKAGE CURRENT (typical)

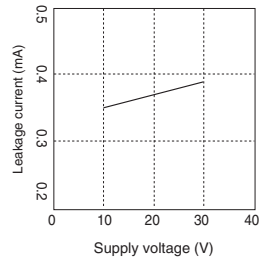

## EXTERNAL DIMENSIONS

(unit: mm)

\*Long sensing distance no-polarity sensors have projecting resin as shown below.

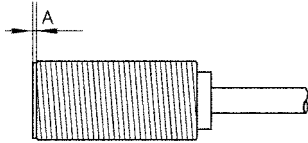

Catalog listing	Dimension A (mm)
FL7M-4□6	0.6
FL7M-8□6	0.6
FL7M-15□6	1.0

### Prelead type

#### FL7M-4□6

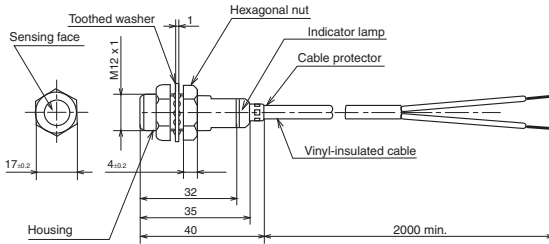

\*The FL7M-4□6 has a 0.6mm projection of resin on the sensing face.  
Vinyl-insulated cable (oil-resistant: 0.3mm<sup>2</sup>, 27/0.12, 2-core), dia. 4.1.  
Cap color: blue.

#### FL7M-8□6

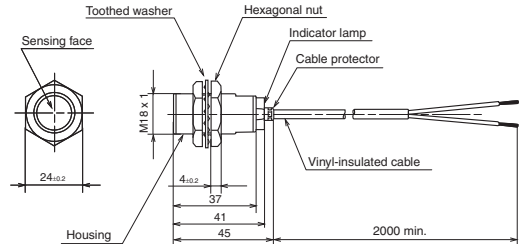

\*The FL7M-8□6 has a 0.6mm projection of resin on the sensing face.  
Vinyl-insulated cable (oil-resistant: 0.5mm<sup>2</sup>, 20/0.18, 2-core), dia. 5.7mm.  
Cap color: blue.

#### FL7M-15□6

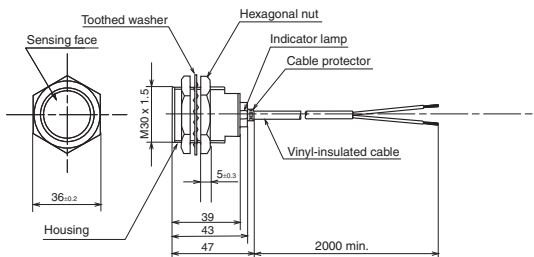

\*The FL7M-15□6 has a 1.0mm projection of resin on the sensing face.  
Vinyl-insulated cable (oil-resistant: 0.5mm<sup>2</sup>, 20/0.18, 2-core), dia. 5.7mm.  
Cap color: blue.

### Prelead connector type

#### FL7M-4□6-CN03

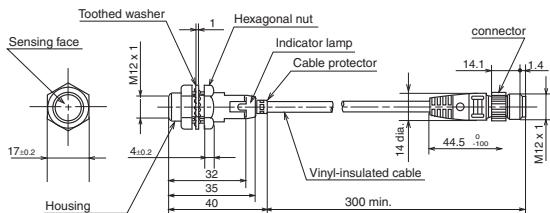

\*The FL7M-4□6 has a 0.6mm projection of resin on the sensing face.  
Vinyl-insulated cable (vibration-resistant, oil-resistant: 0.3mm<sup>2</sup>, 27/0.12, 2-core), dia. 4.1mm. Cap color: blue.

#### FL7M-8□6-CN03

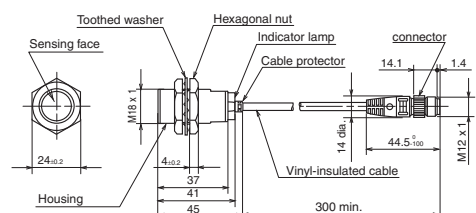

\*The FL7M-8□6 has a 0.6mm projection of resin on the sensing face.  
Vinyl-insulated cable (vibration-resistant, oil-resistant: 0.5mm<sup>2</sup>, 20/0.18, 2-core), dia. 5.7mm. Cap color: blue.

**FL7M-15□6□-CN03**

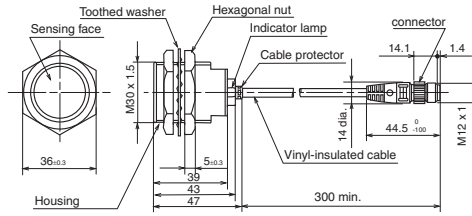

\*The FL7M-15□6□ has a 1.0mm projection of resin on the sensing face.  
 Vinyl-insulated cable (vibration-resistant, oil-resistant: 0.5mm<sup>2</sup>, 20/0.18, 2-core), dia. 5.7mm.  
 Cap color: blue.

**MOUNTING BRACKET (sold separately)**

Mounting brackets are made of polyacetal resin.  
 Two screws and two washers are provided for each bracket.

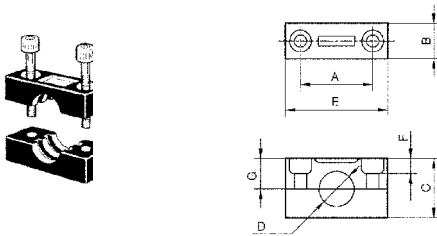

FL-PA118 and FL-PA130 screw holes are oblong.

Catalog listing	Dimensions (mm)							Screw size	
	A	B	C	D	E	F	G	Dia.	Neck
FL-PA112	25	12	20	12dia.	36	6	9.5	M4	25
FL-PA118	30/32	15	30	18dia.	45	7.5	14.5	M5	35
FL-PA130	40/45	15	50	30dia.	60	10	24.5	M5	55

**Allowable tightening torque of bracket screws**

Catalog listing	Max. torque (N·m)
FL-PA112	0.98
FL-PA118	1.5
FL-PA130	1.5

**PROTECTIVE COVER (sold separately)**

Protective covers made of polyacetal resin are available for shielded models.  
 Select a model according to the sensor's external dimensions.

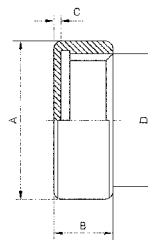

Catalog listing	Dimensions (mm)			
	A	B	C	D
FL-PA12	14dia.	5	0.5	M12 x 1
FL-PA18	21dia.	6	0.5	M18 x 1
FL-PA30	33dia.	8	1.5	M30 x 1.5

**SPATTER-GUARDED PROTECTIVE COVER (sold separately)**

Spatter-guarded protective covers made of fluorine resin and designed especially for shielded sensors are available.  
 Select a model according to the sensor's external dimensions.

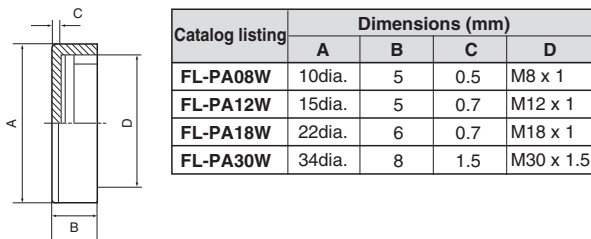

Catalog listing	Dimensions (mm)			
	A	B	C	D
FL-PA08W	10dia.	5	0.5	M8 x 1
FL-PA12W	15dia.	5	0.7	M12 x 1
FL-PA18W	22dia.	6	0.7	M18 x 1
FL-PA30W	34dia.	8	1.5	M30 x 1.5

## WIRING DIAGRAMS

### Preloaded type

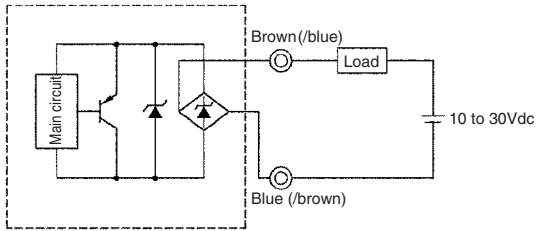

### Preloaded connector type (N.C.)

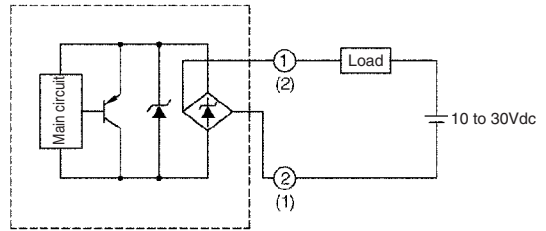

### Preloaded connector type (N.O.)

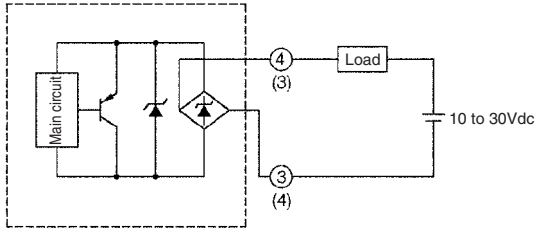

- The load may be connected to either pole.
- The LED operates normally during a load short circuit, so check the wiring if the output is wrong.
- Fasten connectors tightly by hand.

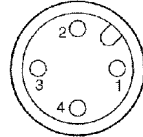

## CONNECTOR SPECIFICATIONS \*1

Item	Specifications
Insulation resistance	Max. 100MΩ (by 500Vdc megger)
Dielectric strength	1,500Vac for 1 minute (between contacts, and between contact and connector housing)
Initial contact resistance	Max. 40mΩ (with 3A current to connected male and female connectors. Semiconductor lead-specific resistance not included.)
Mating/unmating force	0.4 to 4.0 N per contact
Mating cycles	50
Connector nut tightening torque	Min. 0.8N·m*2
Cable pullout strength	Min. 100 N
Vibration resistance	10 to 55Hz, 1.5mm peak-to-peak amplitude, for 2 hours each in X, Y and Z directions
Impact resistance	300m/s <sup>2</sup> , 3 times each in X, Y and Z directions
Protective structure	IP67
Ambient operating temperature	-10 to +70°C
Ambient storage temperature	-20 to +80°C
Ambient operating humidity	Max. 95% RH
Material	Contacts: Gold-plated brass Contact holder: Glass-lined polyester resin Housing: Polyester elastomer Coupling: Ni-plated brass O-ring: NBR



\*1: Specifications assume Yamatake male/female connectors.

\*2: The recommended torque is 0.4 to 0.6N·m. If fastened poorly, the IP67 protection is lost, or looseness occurs. Fasten the connector securely by hand.

## CABLE WITH CONNECTOR

Be sure to use PA5 Series cables with connector to connect preleaded type connectors and connector type limit switches.

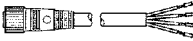
### ● PA5 Series cable with connector

Shape	Power supply	Cable properties	Cable length	Catalog listing	Lead colors
	DC	Oil-resistant, flexible; UL2464; flame-resistant; EN-compliant	2m	PA5-4ISX2MK-E	1: brown, 2: white, 3: blue, 4: black
			5m	PA5-4ISX5MK-E	1: brown, 2: white, 3: blue, 4: black
			2m	PA5-4ILX2MK-E	1: brown, 2: white, 3: blue, 4: black
			5m	PA5-4ILX5MK-E	1: brown, 2: white, 3: blue, 4: black

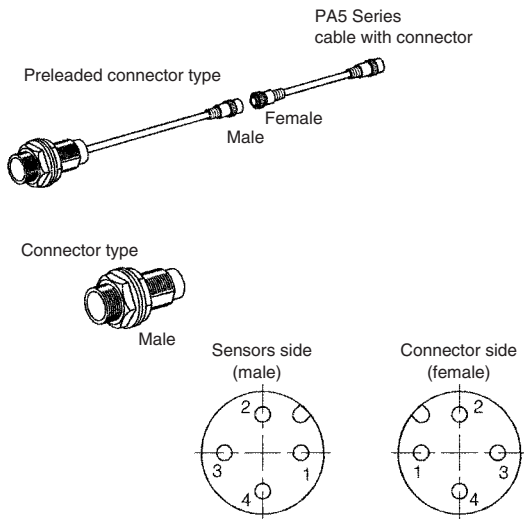

### ● Tightening the connector

Align the grooves and rotate the fastening nut on the PA5 connector by hand until it fits tightly with the connector on the sensors side.

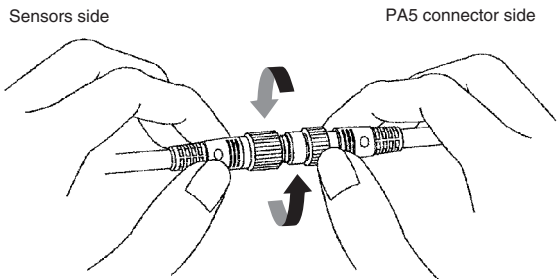

## PRECAUTIONS FOR USE

### 1.1 Mounting

The allowable tightening torque varies according to the distance from the sensing face.

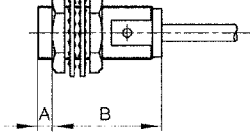

Catalog listing	Length A (mm)	Max. tightening torque (N-m)	
		A	B
FL7M-4□6	10	20	30
FL7M-8□6	0	—	70
FL7M-15□6	0	—	150

\*The table shows the allowable tightening torque when toothed washers (provided) are used.

### 1.2 Influence of surrounding metal

Metal other than the target object surrounding the sensor may influence operating characteristics. Leave space between the sensor and surrounding metal as shown below.

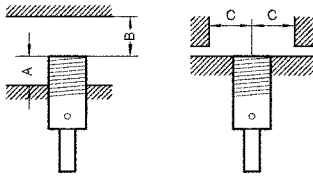

Shaded areas indicate surrounding metal other than the target object.

A: Distance from sensing face of proximity sensor to mounting surface

B: Distance from surface of iron plate to sensing face of proximity sensor.

Dimensions in parentheses apply if a hexagonal nut is attached to the front.

C: Distance from surface of iron plate to center of proximity switch when A=0

Catalog listing	A(mm)	B(mm)	C(mm)
FL7M-4□6	2.5( 5.5)	12	9
FL7M-8□6	3.5( 6.5)	24	13.5
FL7M-15□6	6 ( 10 )	45	22.5

### 1.3 Mutual interference prevention

When mounting proximity sensors either parallel to or facing each other, mutual interference may cause the sensor to malfunction. Maintain at least the distances indicated in the figures below.

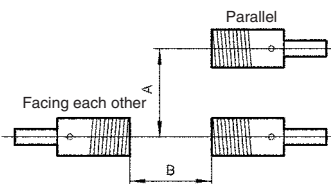

Catalog listing	A(mm)	B(mm)
FL7M-4□6	25	25
FL7M-8□6	40	50
FL7M-15□6	90	110

### 1.4 Cautions for series or parallel connection

#### Series connection (AND switching circuit)

When connecting two or more proximity sensors in series, erroneous output (1 to 3ms) may occur without the rated current being supplied to each of the sensors. For this reason, series connection of proximity sensors is not recommended. However, if proximity sensors must be connected in series, a resistor of 10kΩ must be put in parallel to each of the sensors. Note that the maximum leakage current in a series connection will be 3.5mA. Operation lag also will occur, resulting in increased voltage drop, and the operation indicator lamp will not light.

Operation lag =

40ms x (No. of sensors in series - 1)

Voltage drop =

Voltage drop of single sensor x No. of sensors in series

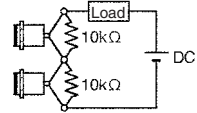

#### Parallel connection (OR switching circuit)

• If two or more proximity sensors are connected in parallel, total leakage current increases according to the following formula, and may result in the load not turning OFF. (Leakage current = Leakage current of single sensor x No. of sensors in parallel)

• When two or more sensors in parallel turn ON, one (or more) of their operating indicators may not light up. This is normal.

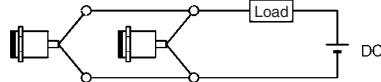

### 1.5 Relay loads

The voltage drop of these FL7M sensors is 5V. Pay attention to this voltage drop when using a relay load. (With 12Vdc relays, switching is not possible.)

### 1.6 Operation upon power ON

After the power is turned ON, it takes at most 40ms until the proximity sensor is ready for sensing. If the load and the proximity sensor use different power supplies, be sure to turn the proximity sensor ON before turning the load ON.

### 1.7 Influence of leakage current

A minimal current flows as leakage current for operating the circuits even when the proximity sensor is OFF. Keep this in mind when turning off connected loads.

### 1.8 Minimum cable bend radius (R)

The minimum bend radius (R) of the cable is 3 times the cable diameter. Take care not to bend the cable beyond this radius. Also, do not excessively bend the cable within 30mm of the cable lead-in port