

# DC 2-Wire Unshielded Cylindrical Proximity Sensors

# FL7M Series

Unshielded sensors achieve especially long sensing distances

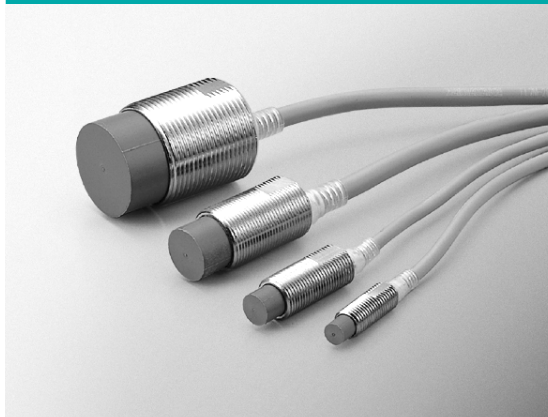

### Long sensing distance

(2 times the sensing distance of a regular FL7M)

DC 2-wire no-polarity function reduces wiring costs

Stable sensing area is shown by the setting indicator

Firefly glow indicator lamp can be seen from any direction



Sealed to IP67G





CLICK

## ORDER GUIDE

### Main unit

Exterior		Sensing distance (mm)	Operation mode	Setting indicator	Oil-resistant cable	Catalog listing
Appearance	Size (O.D.)					
(Firefly indicator) Preleaded type (2m cable) 	M8	4mm	N.O.	●	●	FL7M-4J6ND
			N.C.	●	●	FL7M-4K6N
	M12	8mm	N.O.	●	●	FL7M-8J6ND
			N.C.	●	●	FL7M-8K6N
	M18	14mm	N.O.	●	●	FL7M-14J6ND
			N.C.	●	●	FL7M-14K6N
	M30	20mm	N.O.	●	●	FL7M-20J6ND
			N.C.	●	●	FL7M-20K6N
(Firefly indicator) Preleaded connector type (30cm cable) 	M8	4mm	N.O.	●	●	FL7M-4J6ND-CN03
	M12	8mm	N.O.	●	●	FL7M-8J6ND-CN03
	M18	14mm	N.O.	●	●	FL7M-14J6ND-CN03
	M30	20mm	N.O.	●	●	FL7M-20J6ND-CN03

### Accessories (sold separately)

Name	Appearance	O.D.	Catalog listing
Mounting bracket		For M12	FL-PA112
		For M18	FL-PA118
		For M30	FL-PA130
Protective cover		For M12	FL-PA12
		For M18	FL-PA18
		For M30	FL-PA30
Spatter-guarded protective cover		For M8	FL-PA08W
		For M12	FL-PA12W
		For M18	FL-PA18W
		For M30	FL-PA30W

## SPECIFICATIONS

Catalog listing		FL7M-4□6N□ (-CN03)	FL7M-8□6N□ (-CN03)	FL7M-14□6N□ (-CN03)	FL7M-20□6N□ (-CN03)
Actuation method		High-frequency oscillation (unshielded)			
Rated sensing distance		4 ±0.4mm	8 ±0.8mm	14 ±1.4mm	20 ±2mm
Usable sensing distance		0 to 3.2mm	0 to 6.4mm	0 to 11.2mm	0 to 16mm
Standard target object		20 x 20 x 1mm iron	30 x 30 x 1mm iron	30 x 30 x 1mm iron	54 x 54 x 1mm iron
Differential travel		15% max. of sensing distance	10% max. of sensing distance		
Rated supply voltage		12/24Vdc			
Operating voltage range		10 to 30Vdc			
Leakage current		0.8mA max.			
Control output		3 to 100mA			
Switching current		3 to 100mA			
Voltage drop		3V max. (at 100mA switching current with 2m cable),			
Output dielectric strength		30Vdc			
Operating frequency		1kHz	800Hz	400Hz	100Hz
Temperature drift (% of sensing distance, taking +25° as standard temp.)		±15% max., in the -25 to +70° range	±10% max., in the -25 to +70° range		±10% max., in the -10 to +60° range
Supply voltage drift		±1% max. of sensing distance, taking rated supply voltage as standard voltage			
Indicator lamps		N.O. type: Operation indication: lights up (orange or green) upon output Setting indication: lights up (green) in stable sensing area N.C. type: Operation indication: orange light goes out in sensing area			
Operating temperature		-25 to +70°			-10 to +60°
Insulation resistance		50MΩmin. (by 500V megger)			
Dielectric strength		1000Vac, 50/60Hz for 1 minute			
Vibration resistance		10 to 55Hz, 1.5mm peak-to peak amplitude, 2 hrs each in X, Y and Z directions			
Shock resistance		980m/s <sup>2</sup> 10 times each in X, Y and Z directions			
Protective structure		IP67 (IEC standard), IP67G (JEM standard)			
Weight	Preleaded type (main unit + standard 2m cable)	Approx. 45g	Approx. 55g	Approx. 130g	Approx. 180g
	Preleaded connector type (main unit + 30cm cable)	Approx. 30g	Approx. 40g	Approx. 70g	Approx. 110g
Circuit protection		Surge absorption, load short-circuit protection, reverse connection protection circuit			
Wiring method		preleaded (standard 2m cable), Preleaded connector (30cm cable)			
Material	Sensor	Case	SUS	Ni-plated brass	
		Sensing face	PBT		
Connector	Connector	Housing	-CN03: polyester elastomer		
		Holder	PBT		
		Contact	-CN03: gold-plated brass		

## USING THE SETTING INDICATOR

The proximity sensor can be set up to detect objects reliably by bringing the sensor progressively closer to the target object and installing the sensor at the point where the indicator lamp (N.O. indication) changes from red to green.

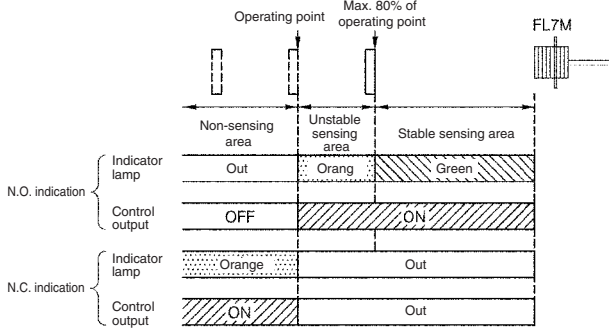

Note: When the target object is made of a different material (such as aluminum, copper or stainless steel) from the standard target object (iron), the distance at which the indicator lamp changes color is shorter than the 80% maximum.

## SENSING AREA (typical)

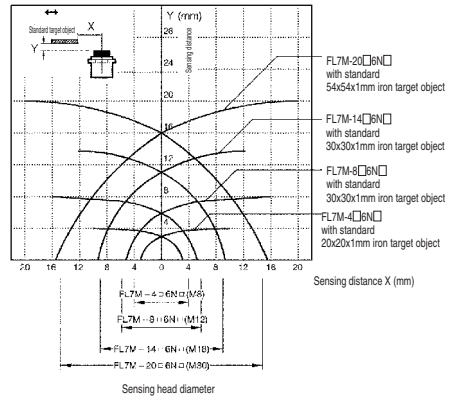

## SENSING DISTANCE ACCORDING TO MATERIAL AND SIZE OF OBJECT (typical)

FL7M-4□6N□

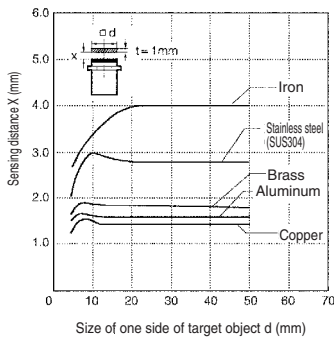

FL7M-8□6N□

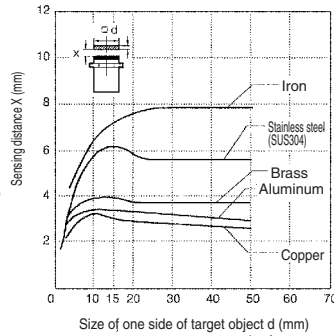

FL7M-14□6N□

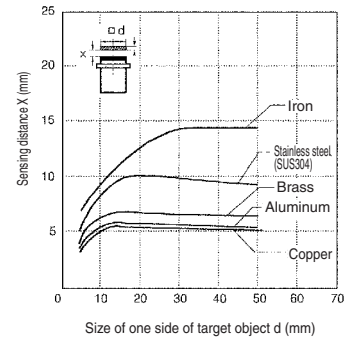

FL7M-20□6N□

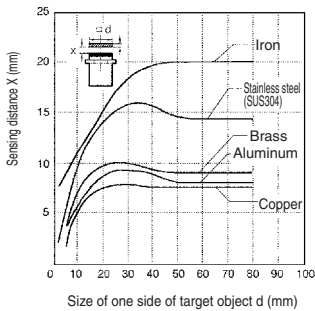

## VOLTAGE DROP (typical)

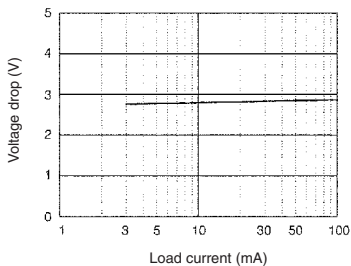

## LEAKAGE CURRENT (typical)

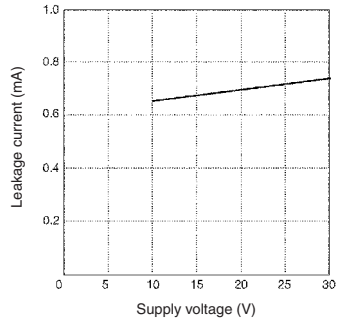

# EXTERNAL DIMENSIONS

(unit: mm)

## Prelead type

**FL7M-4□6N□**

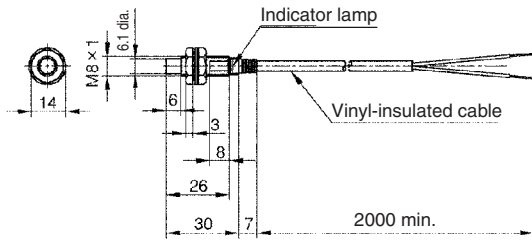

Vinyl-insulated cable (oil-resistant: 0.3mm<sup>2</sup>, 60/0.08, 2-core), dia. 4.  
Cap color: blue.

**FL7M-8□6N□**

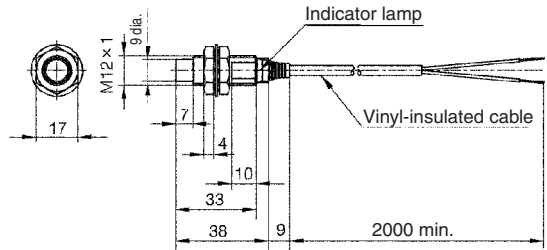

Vinyl-insulated cable (oil-resistant: 0.3mm<sup>2</sup>, 60/0.08, 2-core), dia. 4.  
Cap color: blue.

**FL7M-14□6N□**

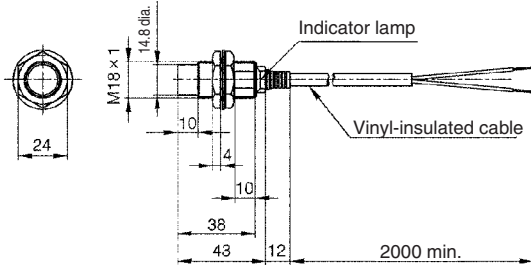

Vinyl-insulated cable (oil-resistant: 0.5mm<sup>2</sup>, 45/0.12, 2-core), dia. 6.  
Cap color: blue.

**FL7M-20□6N□**

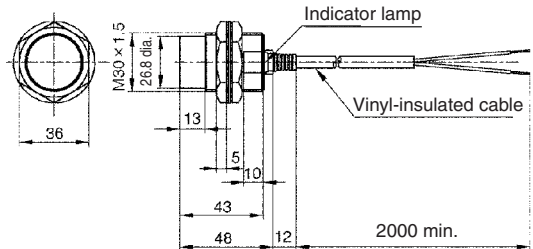

Vinyl-insulated cable (oil-resistant: 0.5mm<sup>2</sup>, 45/0.12, 2-core), dia. 6.  
Cap color: blue.

## Prelead connector type

**FL7M-4□6N□-CN□□**

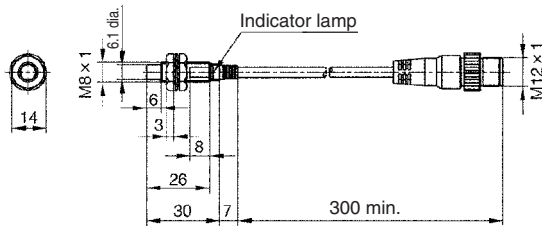

Cap color: blue.

**FL7M-8□6N□-CN□□**

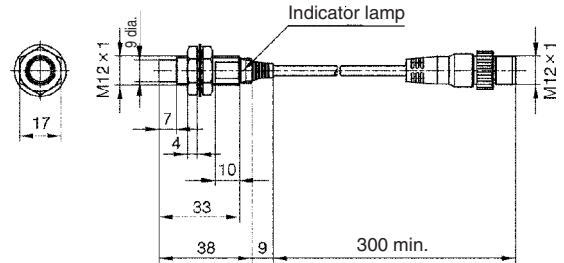

Cap color: blue.

**FL7M-14□6N□-CN□□**

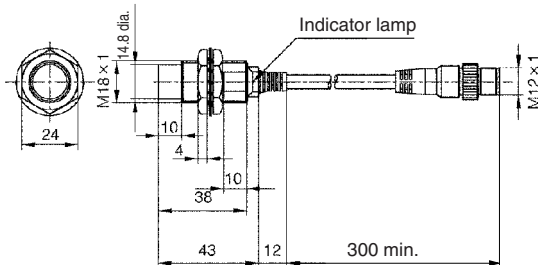

Cap color: blue.

**FL7M-20□6N□-CN□□**

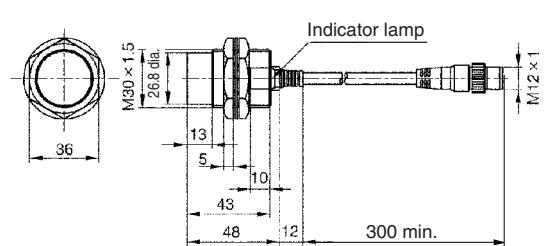

Cap color: blue.

## MOUNTING BRACKET (sold separately)

Mounting brackets are made of polyacetal resin.

Two screws and two washers are provided for each bracket.

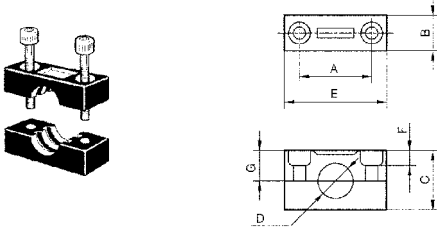

FL-PA118 and FL-PA130 screw holes are oblong.

Catalog listing	Dimensions (mm)							Screw size	
	A	B	C	D	E	F	G	Dia.	Neck
FL-PA112	25	12	20	12dia.	36	6	9.5	M4	25
FL-PA118	30/32	15	30	18dia.	45	7.5	14.5	M5	35
FL-PA130	40/45	15	50	30dia.	60	10	24.5	M5	55

### Allowable tightening torque of bracket screws

Catalog listing	Max. torque (N-m)
FL-PA112	0.98
FL-PA118	1.5
FL-PA130	1.5

## WIRING DIAGRAMS

### Preleaded type

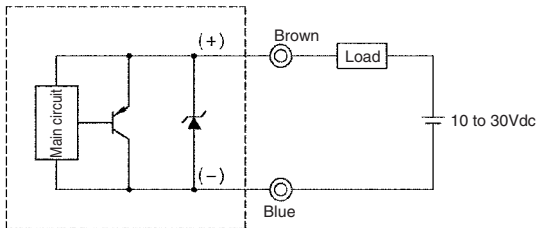

### Preleaded connector type (N.C.)

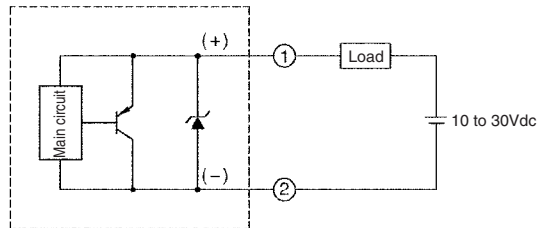

### Preleaded connector type (N.O.)

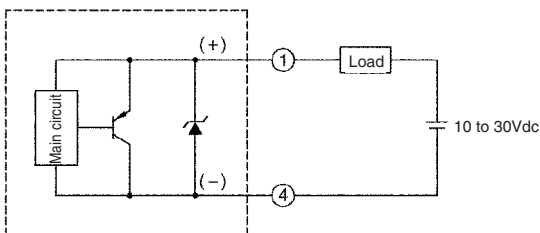

- The load may be connected to either pole.
- A load must be used when power is supplied to the sensor. Although there is short-circuit protection, a combination of a short circuit and wrong wiring can permanently damage the sensor.
- The LED operates normally during a load short circuit, so check the wiring if the output is wrong.
- Fasten connectors tightly by hand.

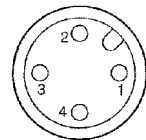

## CONNECTOR SPECIFICATIONS \*1

Item	Specifications
Insulation resistance	Max. 100MΩ(by 500Vdc megger)
Dielectric strength	1,500Vac for 1 minute (between contacts, and between contact and connector housing)
Initial contact resistance	Max. 40mΩ (with 3A current to connected male and female connectors. Semiconductor lead-specific resistance not included.)
Mating/unmating force	0.4 to 4.0 N per contact
Mating cycles	50
Connector nut tightening torque	Min. 0.8N·m*2
Cable pullout strength	Min. 100 N
Vibration resistance	10 to 55Hz, 1.5mm peak-to-peak amplitude, for 2 hours each in X, Y and Z directions
Impact resistance	300m/s <sup>2</sup> , 3 times each in X, Y and Z directions
Protective structure	IP67
Ambient operating temperature	-10 to +70°C
Ambient storage temperature	-20 to +80°C
Ambient operating humidity	Max. 95% RH
Material	Contacts: Gold-plated brass Contact holder: Glass-lined polyester resin Housing: Polyester elastomer Coupling: Ni-plated brass O-ring: NBR

\*1: Specifications assume Yamatake male/female connectors.

\*2: The recommended torque is 0.4 to 0.6N·m. If fastened poorly, the IP67 protection is lost, or looseness occurs. Fasten the connector securely by hand.

## CABLE WITH CONNECTOR

Be sure to use PA5 Series cables with connector to connect preleaded type connectors and connector type limit switches.

### PA5 Series cable with connector

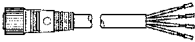
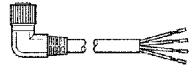
Shape	Power supply	Cable properties	Cable length	Catalog listing	Lead colors
	DC	Oil-resistant, flexible; UL2464; flame-resistant; EN-compliant	2m	PA5-4ISX2MK-E	1: brown, 2: white, 3: blue, 4: black
			5m	PA5-4ISX5MK-E	1: brown, 2: white, 3: blue, 4: black
			2m	PA5-4ILX2MK-E	1: brown, 2: white, 3: blue, 4: black
			5m	PA5-4ILX5MK-E	1: brown, 2: white, 3: blue, 4: black

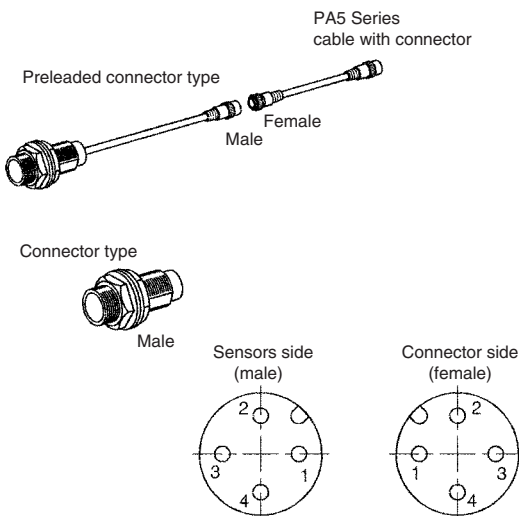

### ● Tightening the connector

Align the grooves and rotate the fastening nut on the PA5 connector by hand until it fits tightly with the connector on the sensors side.

Sensors side

PA5 connector side

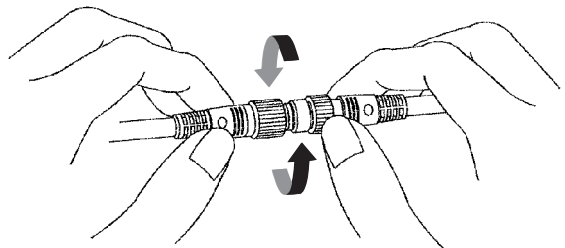

## PRECAUTIONS FOR USE

### 1. Mounting

The allowable tightening torque varies according to the distance from the sensing face.

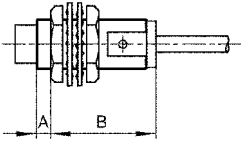

Catalog listing	Length A (mm)	Max. tightening torque (N·m)	
		A	B
FL7M-4□6N□	3	9	7.8
FL7M-8□6N□	0	—	19.6
FL7M-14□6N□	0	—	70
FL7M-20□6N□	0	—	180

Note: The table shows the allowable tightening torque when toothed washers (provided) are used.

### 2. Influence of surrounding metal

Metal other than the target object surrounding the sensor may influence operating characteristics. Leave space between the sensor and surrounding metal as shown below.

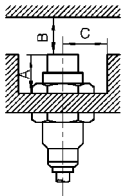

Shaded areas indicate surrounding metal other than the target object.

A: Distance from sensing face of proximity sensor to mounting surface

B: Distance from surface of iron plate to sensing face of proximity sensor.

C: Distance from surface of iron plate to center of proximity switch when A=0

Catalog listing	A(mm)	B(mm)	C(mm)
FL7M-4□6N□	12	8	12
FL7M-8□6N□	15	20	20
FL7M-14□6N□	22	40	35
FL7M-20□6N□	30	70	45

### 3. Mutual interference prevention

When mounting proximity sensors either parallel to or facing each other, mutual interference may cause the sensor to malfunction. Maintain at least the distances indicated in the figures below.

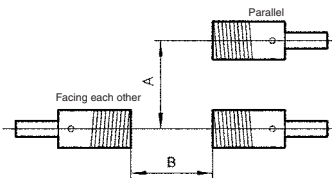

Catalog listing	A(mm)	B(mm)
FL7M-4□6N□	60	80
FL7M-8□6N□	100	120
FL7M-14□6N□	110	200
FL7M-20□6N□	200	300

### 4. Cautions for series or parallel connection

#### (1) Series connection (AND switching circuit)

When connecting two or more proximity sensors in series, erroneous output (1 to 3ms) may occur without the rated current being supplied to each of the sensors. For this reason, series connection of proximity sensors is not recommended. However, if proximity sensors must be connected in series, a resistor of 10kΩ must be put in parallel to each of the sensors. Note that the maximum leakage current in a series connection will be 3.5mA. Operation lag also will occur, resulting in increased voltage drop, and the operation indicator lamp will not light.

$$\text{Operation lag} = 40\text{ms} \times (\text{No. of sensors in series} - 1)$$

$$\text{Voltage drop} = \text{Voltage drop of single sensor} \times \text{No. of sensors in series}$$

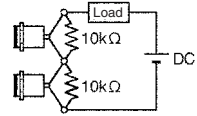

#### (2) Parallel connection (OR switching circuit)

• If two or more proximity sensors are connected in parallel, total leakage current increases according to the following formula, and may result in the load not turning OFF.

(Leakage current = Leakage current of single sensor x No. of sensors in parallel)

• When two or more sensors in parallel turn ON, one (or more) of their operating indicators may not light up. This is normal.

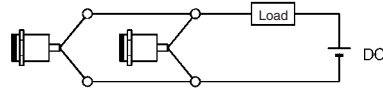

### 5. Relay loads

The voltage drop of these FL7M sensors is 3V. Pay attention to this voltage drop when using a relay load. (With 12Vdc relays, switching is not possible.)

### 6. Operation upon power ON

After the power is turned ON, it takes at most 40ms until the proximity sensor is ready for sensing. If the load and the proximity sensor use different power supplies, be sure to turn the proximity sensor ON before turning the load ON.

### 7. Influence of leakage current

A minimal current flows as leakage current for operating the circuits even when the proximity sensor is OFF. Keep this in mind when turning off connected loads.

### 8. Minimum cable bend radius (R)

The minimum bend radius (R) of the cable is 3 times the cable diameter. Take care not to bend the cable beyond this radius. Also, do not excessively bend the cable within 30mm of the cable lead-in port.