

LJS-E Series

Die-cast safety interlock switches with solenoid lock.

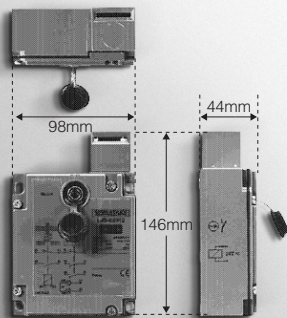

For details on dimensions, see relevant drawings.

- UL/CSA/CE markings
- ⊖ Forced contact-opening mechanism (N.C. contact only)
- Superior IP67 seal
- Indicator provided as a standard feature





▲
CLICK

ORDER GUIDE

• Body

Contact type	Lock method	Catalog listing
N.C. × 2 + N.O. × 1	Locked when solenoid is not energized.	LJS-E7312
N.C. × 1 + N.O. × 2		LJS-E5312
N.C. × 2 + N.O. × 1	Locked when solenoid is energized.	LJS-E7512
N.C. × 1 + N.O. × 2		LJS-E5512

• Tongued key

Shape	Catalog listing
Straight type 	LJS-Z01
Right angle type 	LJS-Z02
Adjustable type 	LJS-Z03

INTERNAL SWITCH

The internal switch of the **LJS-E** Series has the N.C./N.O. electrically independent contact (Zb) structure.

Additionally, the contact forced open structure is used to forcibly open the contact (N.C. contact only) even if the contact is fused accidentally.

As the switch is pushed in, the contact is opened forcibly.

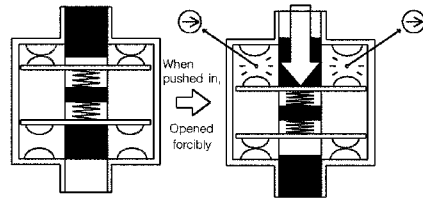

PERFORMANCE

Catalog listing		LJS-E□312	LJS-E□512
Standards	Conformed standards	Product related: IEC 60947-5-1, EN 60947-5-1 Machine related: IEC 60204-1, EN 60204-1, EN 1088	
	Approved standards	UL/CSA	
Structure	Protective structure	IP67 (JIS C 0920), (IEC 60529)	
	Electrical shock protection	class I (IEC 60536)	
	Internal switch	Slow action	
	Lock method	Locked when the solenoid is not energized.	Locked when the solenoid is energized.
Electrical performance	Body	Electrical rating	AC-15: 24/48V 6A DC-13: 24/48V 0.55A
		Rated energizing current (Ith)	6A
		Short-circuit protective device	Breaking fuse 10A type gG (gl)
		Rated insulation voltage (Ui)	500V IEC 60947-1, 300V UL 508/CSA
		Conditional rated short-circuit current	1,000A
		Rated impulse withstanding voltage (Uimp)	4,000V
	Solenoid coil	Load factor	100%
		Rated insulation voltage	AC/DC 24V
		Allowable voltage variation range	-20%, +10%
		Electrical life	Average life: 20,000hrs.
		Power consumption	Rush: 10VA, Retention: 10VA
		LED indicator	Rated insulation voltage
	Mechanical performance	Impact resistance	100m/s ² (11ms) IEC 60068-2-27
		Vibration resistance	50m/s ² (10 to 500Hz) IEC 60068-2-6
Tongued key operating speed		0.01m/s to 0.5m/s	
Mechanical operating frequency		10 operations/min.	
Life	Mechanical life	1million operations or more	
	Electrical life	1million operations or more	
Environmental conditions	Operating temperature range	-25 to +40°C (No freezing allowed.)	
	Operating humidity range	85%RH or less	
Recommended tightening torque	Body	5 to 6N-m (M5 hexagon socket head cap bolt)	
	Cover	1.5 to 3.0N-m (M5 round head screw), 1.5N-m (M4 round head screw)	
	Terminal	0.8N-m (M3 binding machine screw)	

Note. Category used AC-15: Solenoid load
DC-13: Solenoid load

Ue: Operating rated voltage
Ie: Operating rated current

CONTACT OPERATION

Catalog listing	LJS-E5312, LJS-E5512	LJS-E7312, LJS-E7512
<p> : Contact close : Contact open : Transient state </p>	<p>Tongued key insertion (NORMAL) state</p>	<p>Tongued key insertion (NORMAL) state</p>
Circuit diagram		

OPERATING CHARACTERISTICS AND EXTERNAL DIMENSIONS

(unit: mm)

• Body

Tongued key removal strength (when locked)	2,000N
Forced opening force (Min.)	20N

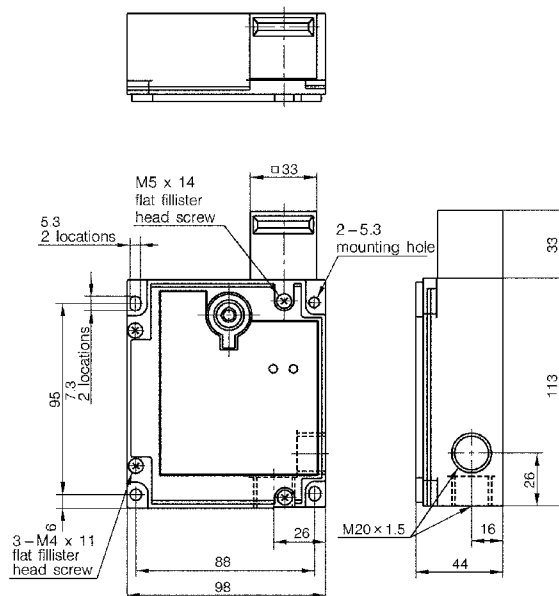

• Tongued key
LJS-Z01

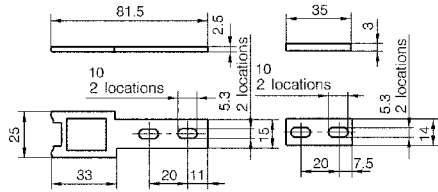

LJS-Z02

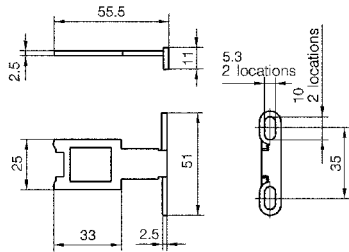

LJS-Z03

(unit: mm)

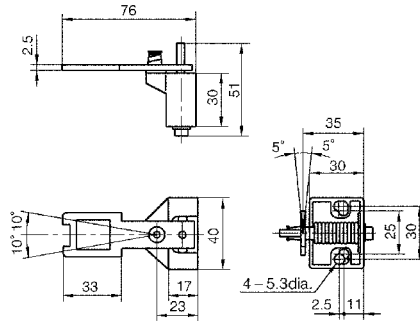

CIRCUIT EXAMPLES

• Example of circuit in category 1 of EN 954-1
Example of circuit, in which a protective fuse is used to prevent the N.C. contact from being closed due to damaged cable or intentional change.
N.C. + N.O. + N.O. (LJS-E5312)

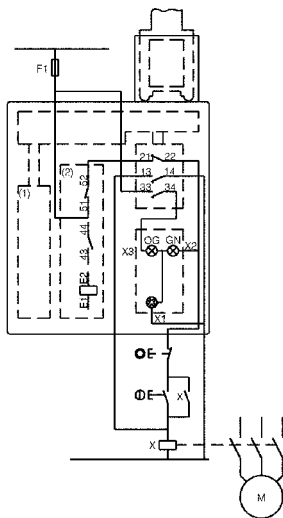

- (1) Solenoid
- (2) Auxiliary contact
- E1-E2: Solenoid power supply (Non-polarity)
- 43-44: Contact for solenoid signal
- 13-14: Contact used as redundancy
- 33-X1: LED (Orange)
Energized when the tongued key is removed.
- 51-X1: LED (Green)
Energized when the tongued key is inserted and locked.
- 21-52: Wiring necessary for safety

• Example of circuit in category 3 of EN 954-1
Example of circuit, in which the switch contact has redundancy without monitor.
N.C. + N.C. + N.O. (LJS-E7312)

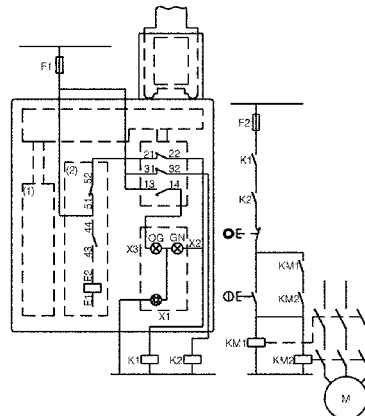

- (1) Solenoid
- (2) Auxiliary contact
- E1-E2: Solenoid power supply (Non-polarity)
- 43-44: Contact for solenoid signal
- 31-32: Contact used as redundancy
- 13-X1: LED (Orange)
Energized when the tongued key is removed.
- 51-X1: LED (Green)
Energized when the tongued key is inserted and locked.
- 21-52: Wiring necessary for safety

• Diagram of tongued key position

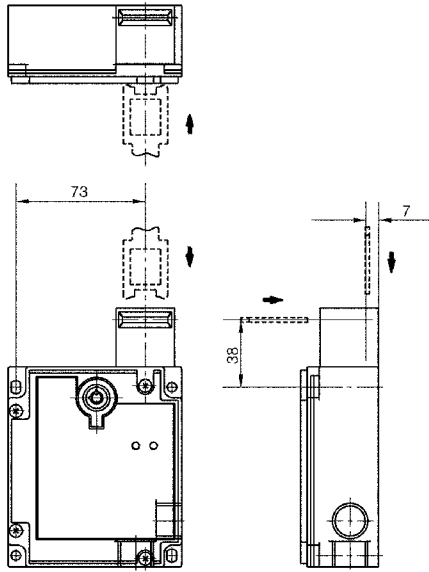

• Diagram of tongued key insertion position

(unit: mm)

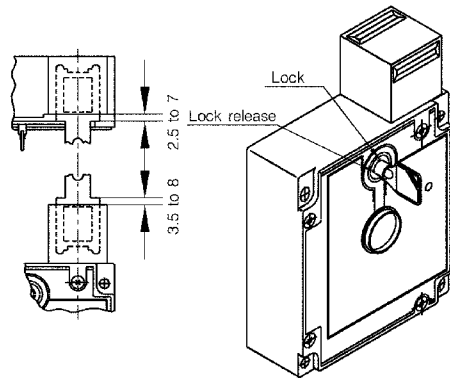

• Actuation radius of tongued key
LJS-Z01/Z02

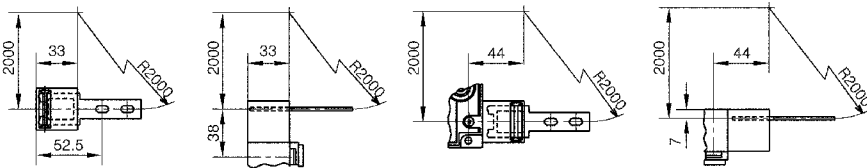

LJS-Z03

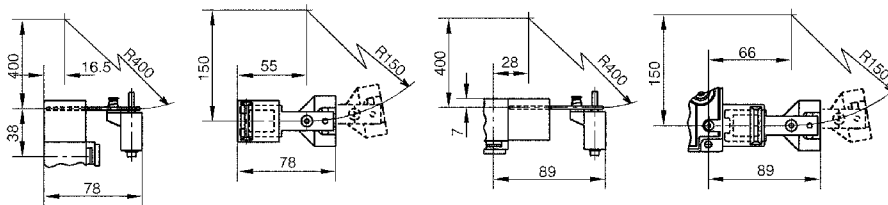

STRUCTURAL DIAGRAM

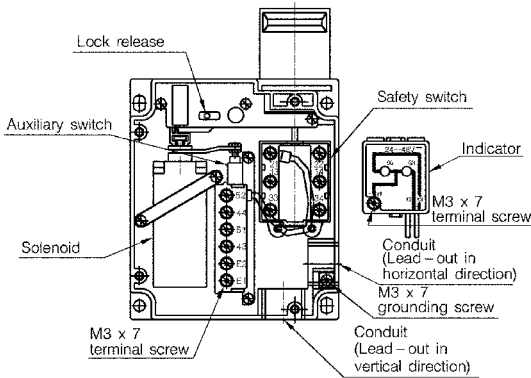

GENERAL CIRCUIT DIAGRAMS

LJS-E5312

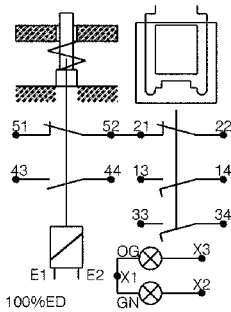

LJS-E7312

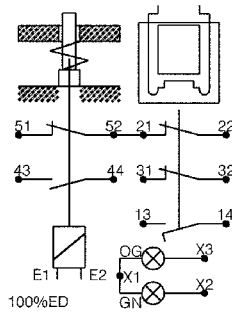

LJS-E5512

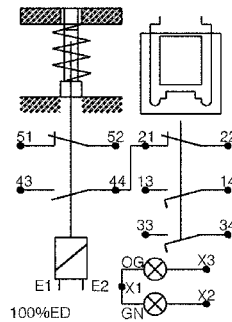

LJS-E7512

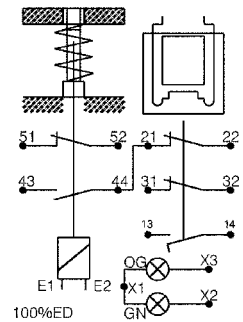

HANDLING PRECAUTIONS

● Mounting the switch

- Always tighten each part of the safety switch with the recommended tightening torque stated in the product specification. If any part is tightened excessively, this might cause damage to the screw and/or other parts. Additionally, insufficient tightening may lead to lowering of various characteristics, such as switch sealing ability.
- Regardless of the door type, do not use the safety switch for the door stopper.
A mechanical door stopper is installed at the end of the door so that any excessive force is not applied to the safety switch.
- Do not apply any excessive impact to the safety switch by opening or closing the door carelessly. If any excessive impact is applied to the switch, this might cause the switch to malfunction.
- When the safety switch is operated in a place where a large amount of foreign matter or dust exists, appropriate measures, such as protective cover are taken to prevent foreign matter or dust from entering the safety switch through the tongued key insertion port. If a large amount of foreign matter or dust enters the safety switch, this may affect the mechanical part, resulting in malfunction.

● Tongued key

- Do not use any tongued key other than that specified.
Operation with a tongued key other than that specified might cause the switch to break.
- Mount the tongued key in a place where it is not in contact with the operator's body when opening or closing the door. Failure to do so might cause personal injury.