

Quick-Connect Cables with Connectors

PA5 Series

Simplifies sensor wiring. Wide variety of connectors attached to cables.

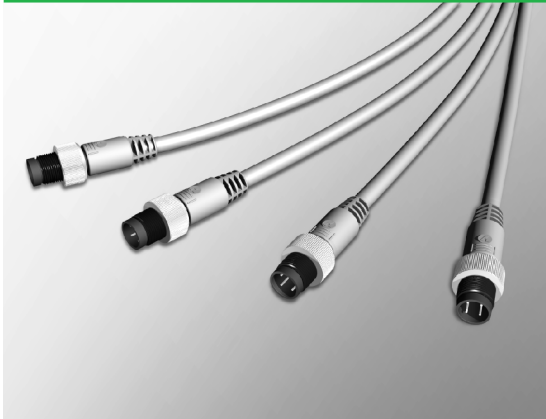

- No wiring or staking work needed
- Shorter replacement time in unlikely event of sensor malfunction
- Simultaneous mechanical assembly and electrical wiring
- Perfect for flexible production lines
- Usable even in harsh environments exposed to cutting oil (IP67)



CLICK

PA5 COMBINATIONS

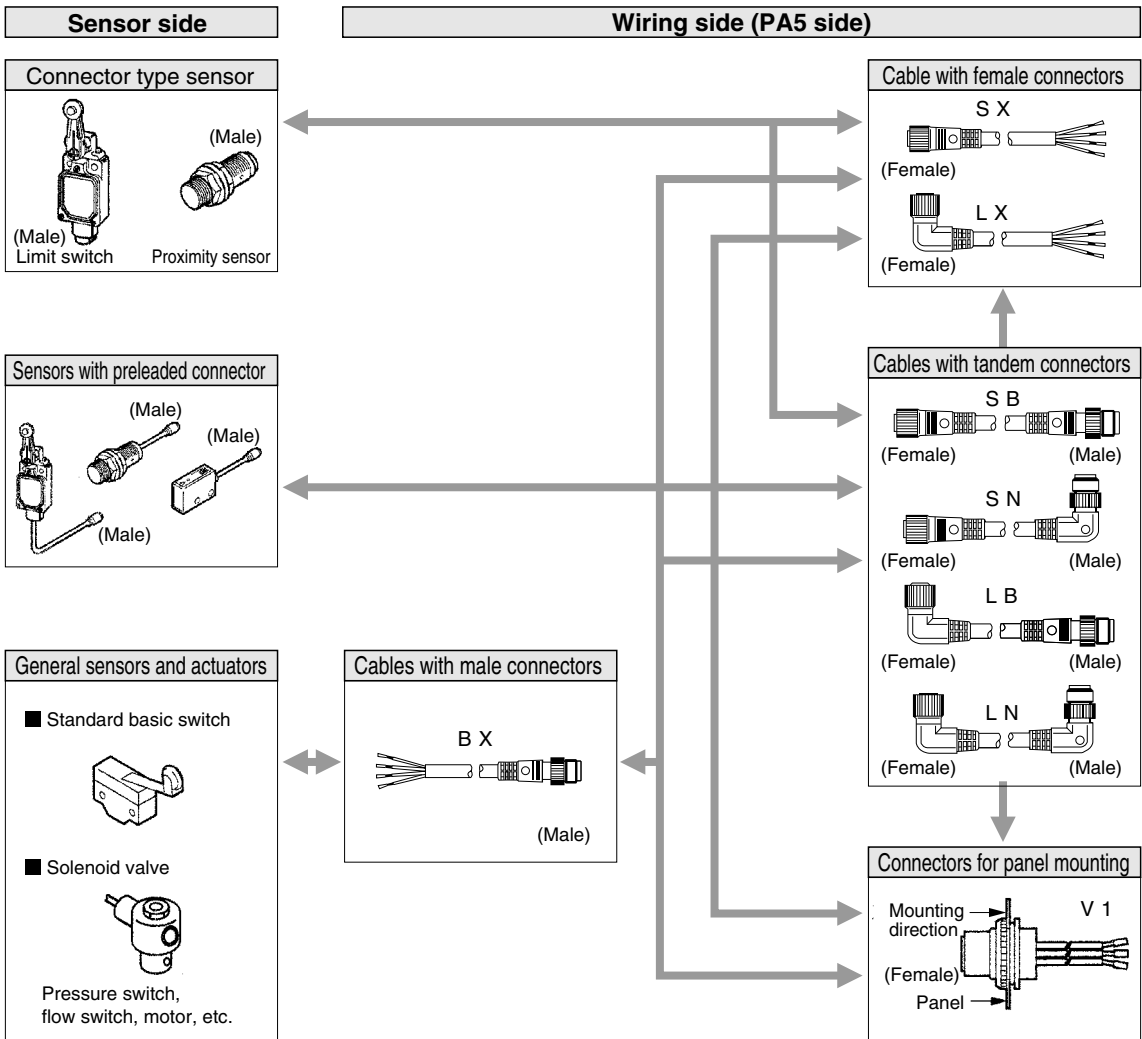

SELECTION GUIDE

Example: PA5-4JSX2HK-E

I	II	III	IV	V	VI	VII
⋮	⋮	⋮	⋮	⋮	⋮	⋮
PA5-	4	J	SX	2	HK	-E

Catalog listing			Description
I	Basic model number	PA5-	PA5 Series cable with connector
II	Number of wires	4	4 cores
III	Type	J	AC (wire colors: brown, white, blue, black)
		I	DC (wire colors: brown, white, blue, black)
IV	Connector shape	SX	Straight (female)
		LX	Angle (female)
		BX	Straight (male)
		SB	Straight (female)- straight (male)
		SN	Straight (female) - angle (male)
		LB	Angle (female) - straight (male)
		LN	Angle (female) - angle (male)
		V1	Panel mounting
V	Cable length	03	0.3m
		05	0.5m
		2	2m
		3	3m
		5	5m
VI	Cable type	HK	6.0mm dia. oil-resistant vinyl cabtyre cable
		MK	6.0mm dia. oil-resistant, flexible, UL2464, flame-resistant flexible vinyl cabtyre cable
		FK	6.1mm dia. oil-resistant, flexible, fluorine resin flame-resistant cabtyre cable
VII	Contact plating	-E	EN-compliant model (TÜV approved model)

Note: Some of the items in the above table cannot be combined. Be sure to check the coding table below to verify that a particular catalog listing is possible.

● Possible combinations for parts I to V of the model number

	0.3m	0.5m	2m	3m	5m
PA5-4□SX			○	○	○
PA5-4□LX			○	○	○
PA5-4□BX	○	○			
PA5-4□SB			○	○	○
PA5-4□SN			○		○
PA5-4□LB			○		○
PA5-4□LN			○		○

APPLICATION EXAMPLES

● Lower maintenance costs due to faster replacement of switches

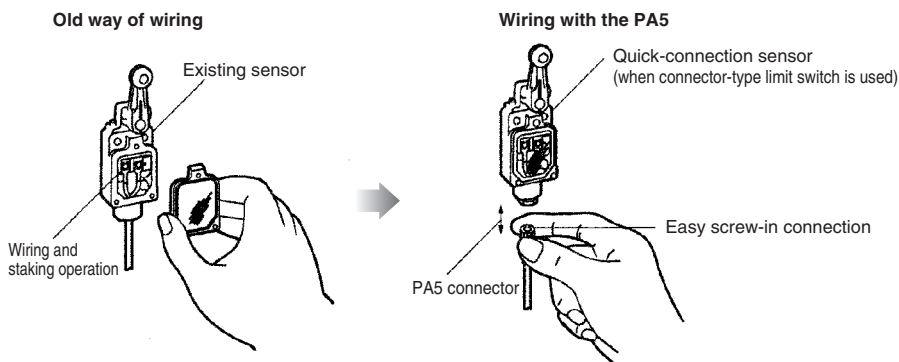

The PA5 simplifies wiring operations

●The connector allows fast connection of the PLC to the sensor

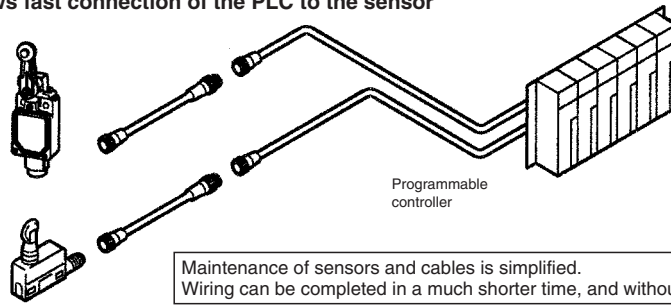

■ CONNECTOR SPECIFICATIONS*1

Item	Specifications
Operating voltage and current	AC type: 5Vac/dc 5mA min., 250Vac 3A, 125Vdc 3A max. DC type: 5Vac/dc 5mA min., 125Vdc 3A max.
Insulation resistance	100MΩmin. (by 500Vdc megger)
Dielectric strength	1,500Vdc for 1 minute (across contacts, and between contacts and connector housing)
Initial contact resistance	40mΩmax. (excluding cable conductor-intrinsic resistance; at 3A with male-female contact combination)
Mating/unmating force	0.4 to 4.0N (per contact)
Mating cycles	50 times
Connector nut torque	0.8N·m min.*2
Cable pullout strength	100N min.
Vibration resistance	10 to 55Hz, 1.5mm peak-to-peak amplitude, 2 hrs each in X, Y, and Z directions
Shock resistance	300m/s ² ; 3 times each in X, Y and Z directions
Protective structure	IP67 (IP65 for panel-mounted type)
Operating temperature	-10 to +70°C
Storage temperature	-20 to +80°C
Operating humidity	95% RH max.
Material	Contacts: gold-plated brass Contact holder: glass-lined polyester resin Housing: polyester elastomer (panel-mounted type: aluminum) Coupling: Orange brass (for AC), Ni-plated brass (for DC) O-ring: NBR

*1. Specifications assume Yamatake male/female connectors.

*2. The recommended tightening torque is 0.4 to 0.6N·m. If fastened poorly, the IP67 protection may be lost, or the connector may come loose.

■ CABLE SPECIFICATIONS

Item	Catalog listing	PA5-4J PA5-4I □□□HK	PA5-4J PA5-4I □□□MK	PA5-4J PA5-4I □□□FK	PA5-4JV1K PA5-4I V1K
External diameter		6.0mm	6.0mm	6.1mm	—
Type of cable		Oil-resistant cabtyre cable	Flexible oil-resistant cabtyre cable	Flexible oil-resistant and flame-resistant fluorine rubber cabtyre cable	Heat resistant vinyl cable
Conductors		0.5mm ² (20/0.18)	0.5mm ² (100/0.08)	0.5mm ² (100/0.08)	AWG24(0.21mm ²)
Number of cores		4	4	4	4
Sheath color		Gray	Gray	Gray	—

●Standardization of lead colors, and connector standards information

Following the establishment of an IEC standard, JIS standards for lead colors of proximity sensors and photoelectric sensors were revised in 1992 (JIS C 4524 for high-frequency proximity switches and JIS C 4525 for photoelectric switches). The standards of the Nippon Electric Control Equipment Industries Association (NECA 0402) were also revised to conform with JIS standards. For this reason, Yamatake has standardized the contact numbers and lead colors of FA sensor connectors as shown in the table. At the same time, the lead number has been conformed to NECA standards (NECA 4202).

We hope that users will understand this temporary inconvenience.

Type	NECA standard for No. of leads	Contact number			
		①	②	③	④
AC	M12 AC: 4	Brown	White	Blue	Black
DC	M12 DC: 4	Brown	White	Blue	Black

CONNECTOR SHAPES

SX

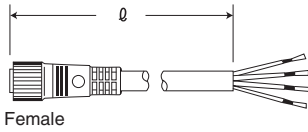

LX

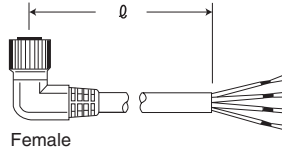

BX

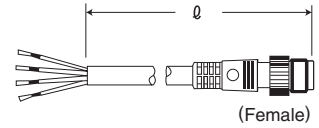

SB

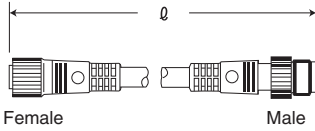

SN

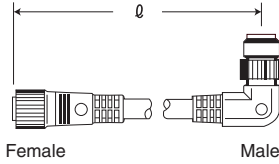

LB

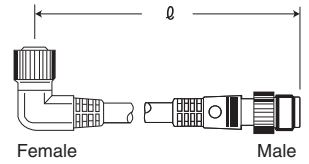

LN

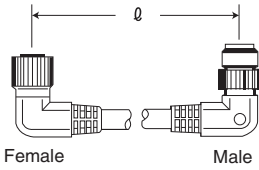

Contact arrangement and lead colors for male/female connectors

Male side



Female side

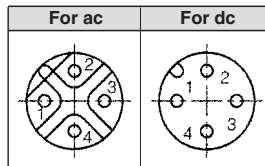
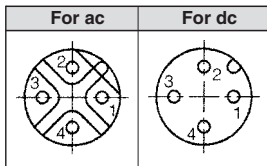
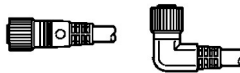

Contact No.	1	2	3	4
Lead colors	Brown	White	Blue	Black

Panel-mounted connector

Power supply: AC, (J type), DC (I type)
Lead colors: brown, white, blue, black

Catalog listing PA5-4 V1 K

Gold-plated contacts
Panel-mounted connector
J: AC
I: DC

Connector shape	Appearance	Power supply	Cable length	Catalog listing
V1	Female	AC	0.5m	PA5-4JV1K
		DC		PA5-4IV1K

● Contact arrangement and lead colors

Female side

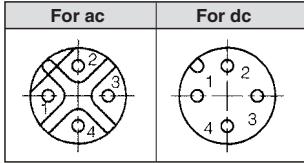

Contact No.	1	2	3	4
Lead colors	Brown	White	Blue	Black

■ EXTERNAL DIMENSIONS OF CONNECTORS (DC cables are shown)

Straight (female)

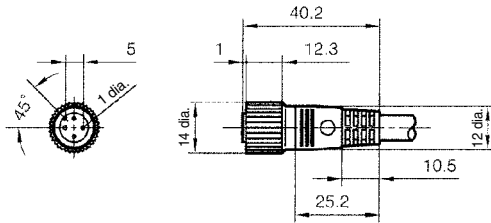

Straight (male)

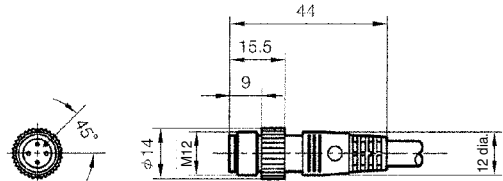

Angle (female)

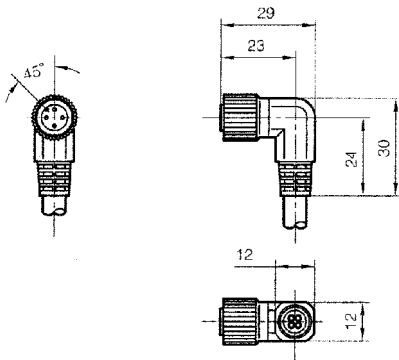

Angle (male)

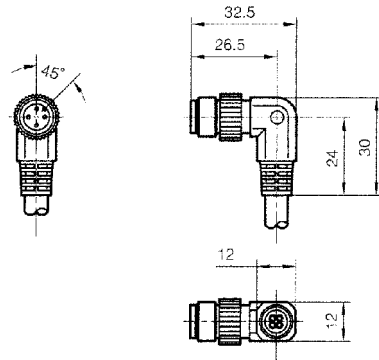

Panel-mounted connector, catalog listing PA5-4□V1K

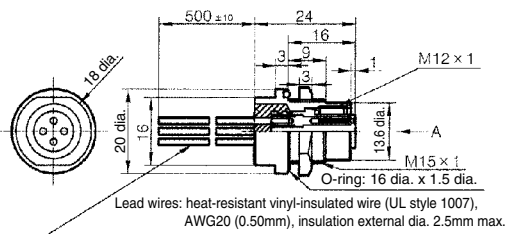

A:DC type

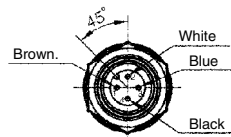

Panel cutout dimensions

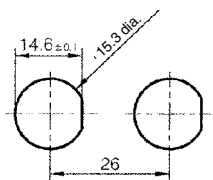

Panel thickness : 1 to 5mm
Recommended mounting centers: 26mm (suitable for socket wrench)

DIMENSIONS WHEN CONNECTED TO CONNECTOR-TYPE SENSOR

The dimensions below apply when the connector is attached. Add space for insertion/disconnection (approx. 15mm) during actual fitting.

For attachment to an angle PA5, calculate the total length as follows:

$$\text{Total length (mm)} = A + 20\text{mm}$$

● Connector-type proximity sensor with angle-type PA5

Connection to connector-type proximity sensor (FL7M)

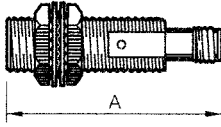

● Connector-type limit switch

Connection to angle-type PA5

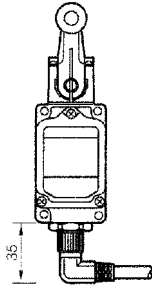

Note: When a connector-type sensor and angle-type PA5 are connected, the direction in which the PA5 cable exits may differ. Pay attention to this direction.

● Connector-type limit switch

with straight PA5

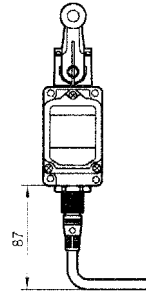

(unit: mm)

PRECAUTIONS FOR USE

● Tightening the connector nut/lock ring

- Take special care if the mating part is made of resin, since the threads can easily be damaged when the connector is first tightened. When assembling the connector, align the center of the cores, push in as far as possible, and tighten.
- Tighten firmly by hand. The recommended tightening torque is 0.4 to 0.6N·m. The use of a tightening tool may damage the connector.
- When securing the lock ring of a PA5-4□V1K, close firmly (0.4 to 0.6 N·m) by hand, or using the dedicated tool (PA5-P1).
- If the connector is not tightened firmly, IP67 protection may be lost, or the connector may come loose.

● Inserting and removing connectors

- Before inserting or removing connectors, be sure to turn the power OFF.
- When removing connectors, do not pull by the cable. Hold the connector by its body when removing.

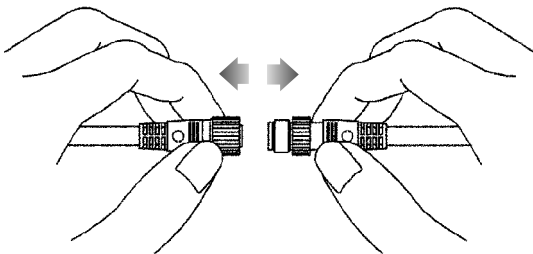

● Inserting and removing connectors

- The direction of the angle plug is restricted by the groove in the opposing plug. When using LX, NX, SX, LB, or LN series connectors, check the position of the groove in the opposing plug.

● Cautions when bending cables

- The minimum bend radius of the cable is 80mm. Make allowance for bends in the cable.

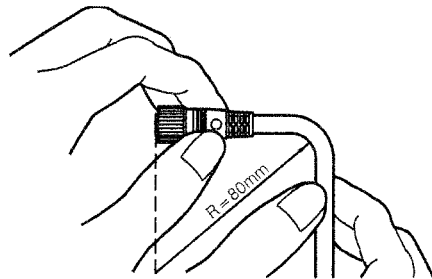

● Protective structure

- IP67 does not imply complete waterproofing. Do not use where constantly exposed to water.
- Avoid use where external force (or weight) is applied continuously on the connecting section of the connector.
- The body is molded resin. Do not step on the body or place heavy objects on it.

● Cautions during replacement

- When removing connectors to replace the sensor or cable, thoroughly wipe the connector and surrounding area to remove any water. After removing the connector, prevent it from being immersed in chemicals or powder, or being dropped. If the connector is accidentally immersed in liquid, allow it to dry completely before connecting again. If the connector is dropped in powder, completely wipe off any powder before connecting again. Failure to observe the above may result in short circuits or poor connections.