

CMC10B Communication Controller (CPL/CPL Converter)

User's Manual Design Manual



Thank you for purchasing the CMC10B. This manual contains information for ensuring correct use of the CMC10B. It also provides necessary information for installation, maintenance, and troubleshooting. This manual should be read by those who design and maintain devices that use the CMC10B. Be sure to keep this manual nearby for handy reference.

RESTRICTIONS ON USE

This product has been designed, developed and manufactured for general-purpose application in machinery and equipment.

Accordingly, when used in applications outlined below, special care should be taken to implement a fail-safe and/or redundant design concept as well as a periodic maintenance program.

- Safety devices for plant worker protection
- Start/stop control devices for transportation and material handling machines
- Aeronautical/aerospace machines
- Control devices for nuclear reactors

Never use this product in applications where human safety may be put at risk.

NOTICE

Be sure that the user receives this manual before the product is used.

Copying or duplicating this user's manual in part or in whole is forbidden. The information and specifications in this manual are subject to change without notice.

Considerable effort has been made to ensure that this manual is free from inaccuracies and omissions. If you should find an error or omission, please contact Yamatake Corporation.

In no event is Yamatake Corporation liable to anyone for any indirect, special or consequential damages as a result of using this product.

©2000 Yamatake Corporation ALL RIGHTS RESERVED

SAFETY PRECAUTIONS

■ About Icons

The safety precautions described in this manual are indicated by various icons. Please be sure you read and understand the icons and their meanings described below before reading the rest of the manual.

Safety precautions are intended to ensure the safe and correct use of this product, to prevent injury to the operator and others, and to prevent damage to property. Be sure to observe these safety precautions.



 **WARNING**

Warnings are indicated when mishandling this product might result in death or serious injury.











 **CAUTION**

Cautions are indicated when mishandling this product might result in minor injury to the user, or only physical damage to the product.

■ Examples

	Use caution when handling the product.
	The indicated action is prohibited.
	Be sure to follow the indicated instructions.

CAUTION

	<p>Before wiring, removing or installing the CMC10B, be sure to turn the power OFF. Failure to do so might cause faulty operation.</p>
	<p>Do not disassemble the CMC10B. Doing so might cause faulty operation.</p>
	<p>Use the CMC10B within the operating ranges (temperature, humidity, voltage, vibration, shock, mounting direction, atmosphere, etc.) recommended in the specifications. Failure to do so might cause fire or faulty operation.</p>
	<p>Do not block ventilation holes. Doing so might cause fire or malfunction.</p>
	<p>Wire the CMC10B properly according to predetermined standards. Also wire the CMC10B using designated power leads according to recognized installation methods. Failure to do so might cause electric shock, fire or faulty operation.</p>
	<p>Do not allow lead clippings, chips or water to enter the CMC10B case. Doing so might cause fire or faulty operation.</p>
	<p>Firmly tighten the terminal screws at the torque listed in the specifications. Insufficient tightening of terminal screws might cause fire.</p>
	<p>Do not use unused terminals on the CMC10B as relay terminals. Doing so might cause electric shock, fire or faulty operation.</p>
	<p>Use Yamatake Corporation's SurgeNon if there is the risk of power surges caused by lightning. Failure to do so might cause fire or faulty operation.</p>
	<p>When disposing the CMC10B, dispose of it as industrial waste, following local regulations.</p>

The Role of This Manual

In all, three manuals have been prepared for the **CMC10B**. Read the manual according to your specific requirements. The following lists all the manuals that accompany the **CMC10B** and gives a brief outline of the manual. If you do not have the required manual, contact Yamatake Corporation or your dealer.

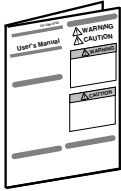

CMC10B Communication Controller (CPL/CPL Converter) Manual No.CP-UM-5129E

This manual is packaged with the CMC10B.

It describes only precautions and how to handle the CMC10B. Be sure to read this manual when installing and wiring the CMC10B.

For further details on how to handle the CMC10B, read the CMC10B Communication Controller (CPL/CPL Converter) Design Manual No. CP-SP-1064E.



CMC10B Communication Controller (CPL/CPL Converter) User's Manual (Design Manual)

Manual No.CP-SP-1064E

This manual.

This manual is required reading for those who use the CMC10B, those who design hardware for integrating the CMC10B into operator control panels, those who carry out maintenance, and those who operate instruments in which the CMC10B is integrated.

It describes an outline of the CMC10B, how to install and wire for integrating the CMC10B into other devices, communications functions, troubleshooting and specifications.

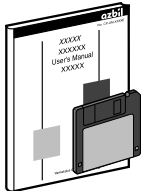

SLP-CM1 Smart Loader Package for the CMC10B Communication Controller (CPL/CPL Converter) User's Manual

Manual No.CP-UM-5141E

This manual is packaged with the SLP-CM1 system disk.

Running the SLP-CM1 package on a personal computer enables you to set up CMC10B parameters on the personal computer.

This manual describes operations on the personal computer.

Organization of This User's Manual

This manual is organized as follows:

Chapter 1. INTRODUCTION

This chapter describes an outline of the CMC10B, its features and a system configuration.

Chapter 2. NAMES & FUNCTIONS OF PARTS

This chapter describes the names and functions of parts on the CMC10B.

Chapter 3. INSTALLATION & SETUP

This chapter describes installation sites for the CMC10B and how to install the CMC10B.

Chapter 4. WIRING

This chapter describes how to connect to the terminals on the CMC10B, cables used and wiring precautions.

Chapter 5. COMMUNICATIONS FUNCTIONS

This chapter describes the communications functions of the CMC10B, structure of messages, commands and other basic information.

Chapter 6. HOW TO USE THE CMC10B

This chapter describes the setup and basic method of use when using the CMC10B for the first time, and describes advanced use of CMC10B's features in more detail.
It also describes other functions that can be used on the personal computer Loader and gives data lists.

Chapter 7. TROUBLESHOOTING

This chapter describes how to remedy trouble that might occur.

Chapter 8. SPECIFICATIONS

This chapter describes the specifications and external dimensions of the CMC10B.

Contents

SAFETY PRECAUTIONS

Unpacking

The Role of This Manual

Organization of This User's Manual

Conventions Used in This Manual

Chapter 1. INTRODUCTION

- Outline 1-1
- Configuration and Features 1-1

Chapter 2. NAMES & FUNCTIONS OF PARTS

- Body 2-1
- Base 2-1
- LED Indications 2-2

Chapter 3. INSTALLATION & SETUP

- Mounting Locations 3-1
- Linking Modules 3-1
- Installation Procedure 3-2

Chapter 4. WIRING

- Cables Used 4-1
- Wiring Precautions 4-1
- Connecting the Power Supply 4-2
- Connecting Local CPL Communications 4-2
- Connecting Host CPL Communications (HOST↔MC) 4-3

Chapter 5. COMMUNICATIONS FUNCTIONS

- 5-1 Outline of Communications 5-1
 - Features 5-1
 - Defaults 5-1
 - Reception and Transmission Timing of Messages 5-1
- 5-2 Message Structure 5-2
 - Message Structure 5-2
 - Data Link Layer 5-2
 - Application Layer 5-4
- 5-3 Description of Commands 5-5
 - Read Continuous Data Command (RS command) 5-5
 - Write Continuous Data Command (WS command) 5-6
 - Read Continuous Fixed Length Data Command (RD command) 5-7
 - Write Continuous Fixed Length Data Command (WD command) 5-8
 - Read Fixed Length Random Data (RU command) 5-9
 - Write Fixed Length Random Data (WU command) 5-10
- 5-4 Numeric Representation in the Application Layer 5-11
- 5-5 Response at Communications Error 5-12

Chapter 6. HOW TO USE THE CMC10B

6-1	Using the CMC10B For the First Time	6-1
■	Host Communications Setup	6-1
■	Local Communications Setup	6-3
■	Local Assignments	6-4
■	Folder Setup	6-7
■	Buffer Data Configuration	6-8
■	Writing Setup Data to the CMC10B	6-9
■	Saving Setup Data	6-9
■	Reading Buffered Data	6-10
6-2	Advanced Use of CMC10B Features	6-11
■	To Write Data to Multiple Local Stations	6-11
■	To Quickly Update Specific Data	6-12
■	To Directly Read and Write to the Local Station from the Host	6-15
■	To Disable Reading and Writing of Some Buffered Data	6-15
■	Selecting LED Indicator Lamp Functions	6-16
■	Adjusting the Response Time with the Local Station	6-18
■	Checking the Buffering State	6-20
■	Reading the Buffered Data Attributes	6-21
6-3	Other Smart Loader Package Functions	6-22
■	Checking the CMC10B Setup	6-22
■	Other Smart Loader Package Functions	6-22
6-4	Data Lists	6-24
■	Loader Setting Lists	6-24
■	CPL Address Map	6-26

Chapter 7. TROUBLESHOOTING

7-1	Communications Is Not Possible	7-1
■	Buffered Data Cannot Be Read	7-1
■	Buffered Data Cannot Be Written	7-2
■	Communications With Host Not Possible	7-2
7-2	Debugging Examples	7-3
■	Checking Communications Parameters	7-3
■	Checking Communications Termination Codes	7-3
■	Checking on Monitor	7-3
■	Self diagnosis	7-4



Chapter 8. SPECIFICATIONS

■	Communications Specifications	8-1
■	General Specifications	8-2
■	External Dimensions	8-3

Index

Conventions Used in This Manual

The following conventions are used in this manual.

-  **Handling Precautions** : Handling Precautions indicate items that the user should pay attention to when handling the **CMC10B**.
-  **Note** : Notes indicate useful information that the user might benefit by knowing.
- (1), (2), (3) : The numbers with the parenthesis indicate steps in a sequence or indicate corresponding parts in an explanation.
- [Open] button : Indicates a selection button in screens displayed on the personal computer.
- [File], [Monitor], [Save] : Indicates messages and menus displayed on the personal computer.
- >> : Indicates the result of an operation, details displayed on the personal computer or devices, or the state of a device after an operation.

Chapter 1. INTRODUCTION

■ Outline

The CMC10B controller is for connecting a host device to local devices such as controllers and recorders that support CPL communications*.

The CMC10B samples the data of the local devices at all times, and ensures trouble-free data communications between the local and host devices.

This increases the performance of communications between multiple CPL communications-compatible local devices and a host device.

* CPL (Controller Peripheral Link) communications is the Yamatake Corporation's host communication protocol.

■ Configuration and Features

- Up to 31 CMC10Bs can be connected to a single host, and up to 31 CPL communications-compatible local devices can be connected to each CMC10B. As a result, up to 961 local devices can be connected to a single host.
- Communications performance when multiple devices are connected can be improved as the CMC10B samples set data at all times.
- The CMC10B supports fixed-length communications which is highly compatible with PLCs, which can reduce the programming load.
- The CMC10B can be linked with the modular controller DMC10 via the RS-485 connector on the side of the body, eliminating the need for wiring.
- The CMC10B can be mounted either on DIN rail or by screws.
- Small and lightweight, the CMC10B helps save space.

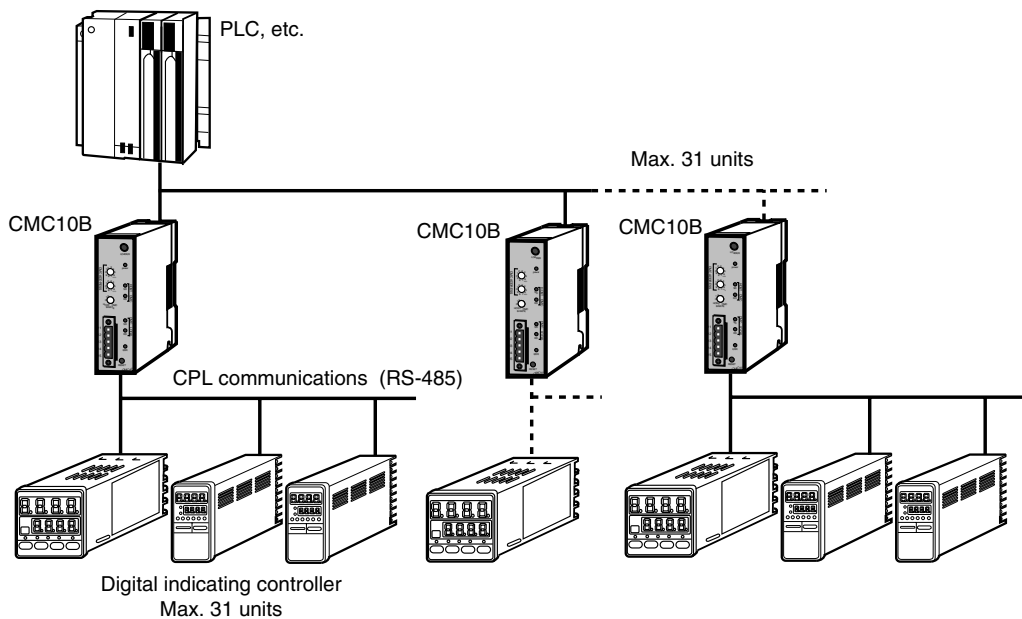

Chapter 2. NAMES & FUNCTIONS OF PARTS

■ Body

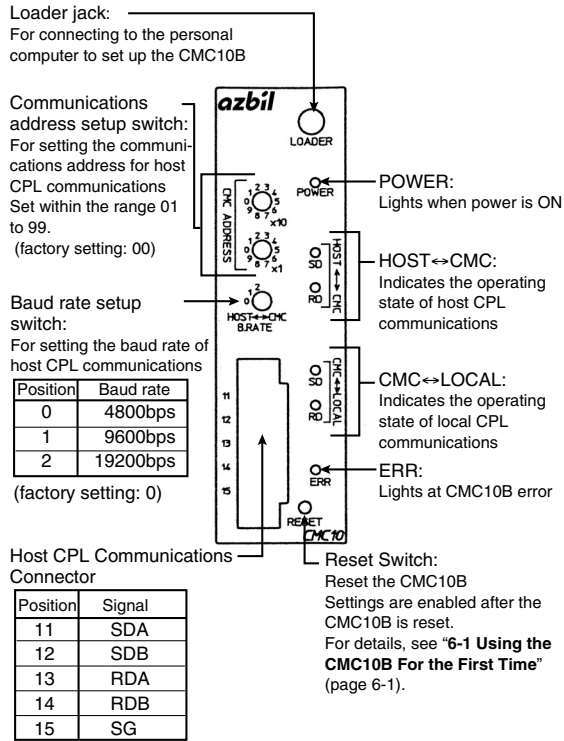

■ Base

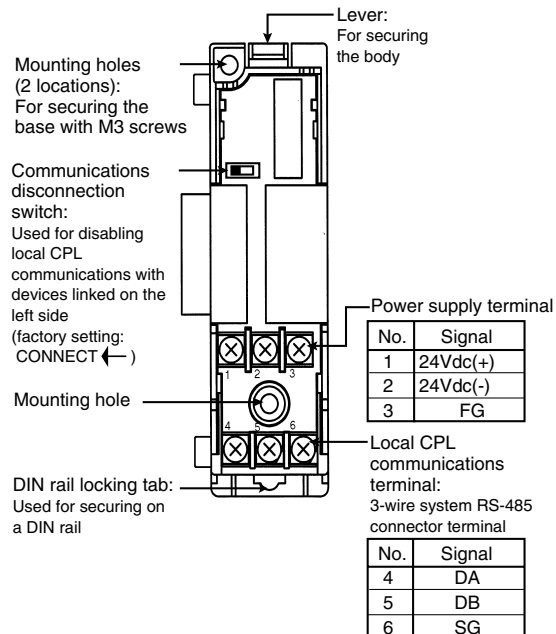

■ LED Indications

Name	Color	Functions	Remarks	
POWER	Green	Lights when the power is ON		
HOST ↔ CMC (host CPL communications)	SD	Yellow	Lights during transmission of communications data on host	These LEDs indicate the operating state of host communications
	RD	Yellow	Lights during reception of communications data on host	
CMC ↔ LOCAL (local CPL communications)	SD	Yellow	Lights during transmission of communications data on local station	These LEDs indicate the operating state of local communications
	RD	Yellow	Lights during reception of communications data on local station	
ERR	Red	Lights at a device error		

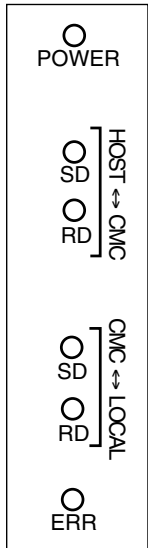

Chapter 3. INSTALLATION & SETUP

CAUTION



Before wiring, removing or installing the CMC10B, be sure to turn the power OFF.

Failure to do so might cause faulty operation.



Do not disassemble the CMC10B.

Doing so might cause faulty operation.



Use the CMC10B within the operating ranges (temperature, humidity, voltage, vibration, shock, mounting direction, atmosphere, etc.) recommended in the specifications.

Failure to do so might cause fire or faulty operation.



Do not block ventilation holes.

Doing so might cause fire or malfunction.



Do not allow lead clippings, chips or water to enter the CMC10B case.

Doing so might cause fire or faulty operation.

■ Mounting Locations

Avoid installing the CMC10B in the following locations:

- Locations subject to high and low temperature, high and low humidity exceeding the specified ranges
- Locations subject to corrosive gases such as sulfide gases
- Locations subject to dust or oil smoke
- Locations subject to direct sunlight, wind or rain
- Locations subject to vibration or shock exceeding the specified ranges
- Locations under high-voltage lines and near sources of electrical noise such as welders
- Locations within 15 meters of high-voltage ignition equipment such as boilers
- Locations where magnetic fields are generated
- Locations near flammable liquid or steam

■ Linking Modules

The CMC10B can be linked with other modules by the connectors located to the left and right of its base.

Modules must be linked before the CMC10B is mounted on the DIN rail or mounted by screws.

When modules are linked, the following signal leads and power leads are connected:

- Local station communications
- 24Vdc power lead
- Event lead (unused on the CMC10B)

The number of modules that can be linked is limited by the following formula:

$$100W \geq \text{Total power consumption of linked modules}$$

Local station communications can be disconnected by the communications

disconnection switch located on the base of the CMC10B.

■ Installation Procedure

The CMC10B can be mounted in either of two ways, by mounting its base by screws or by securing on a DIN rail.

! Handling Precautions

Install this module so that it is vertical, with the DIN rail locking tab at the bottom.

● When mounting the base by screws

(1) Mounting the base by screws

Secure the two mounting holes on the base by M3 screws.

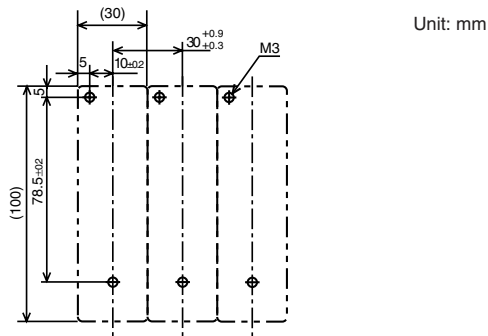

(2) Mounting the body on the base

Fit the hook into the base and push the body into the base until you hear it click into place.

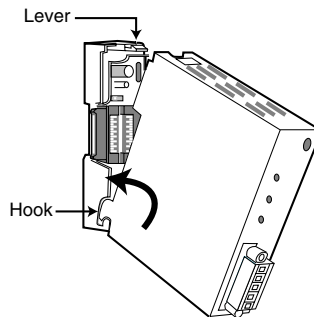

To remove the body from the base, pull the body towards you while pressing down on the lever.

● When securing on a DIN rail

Secure the CMC10B on the DIN rail, fully draw out the DIN rail stopper and hook the base onto the DIN rail. Next, push the DIN rail locking tab upwards until you hear it click into place.

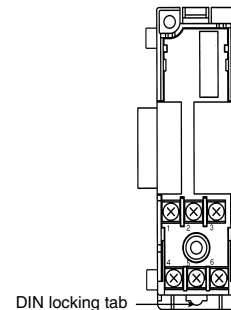



Chapter 4. WIRING

⚠ CAUTION

- 

Before wiring, removing or installing the CMC10B, be sure to turn the power OFF.
Failure to do so might cause faulty operation.
- 

Wire the CMC10B properly according to predetermined standards.
Also wire the CMC10B using designated power leads according to recognized installation methods.
Failure to do so might cause electric shock, fire or faulty operation.
- 

Firmly tighten the terminal screws at the torque listed in the specifications.
Insufficient tightening of terminal screws might cause fire.
- 

Do not use unused terminals on the CMC10B as relay terminals.
Doing so might cause electric shock, fire or faulty operation.
- 

Use Yamatake Corporation's SurgeNon if there is the risk of power surges caused by lightning.
Failure to do so might cause fire or faulty operation.

■ Cables Used

- Use shielded polyethylene insulated vinyl sheathed cable JCS-364 for instrumentation for inputs/outputs.
(Normally, this is referred to as twisted cable for instrumentation.)

Recommended Twisted Cable Leads

Fujikura Ltd.	2-lead	IPEV-S — 0.9mm ² x 1P KPEV-S — 0.9mm ² x 1P
	3-lead	ITEV-S — 0.9mm ² x 1T KTEV-S — 0.9mm ² x 1T

- When there is comparatively little electromagnetic conduction, shielded multi-core microphone cord (MVVS) can be used.

■ Wiring Precautions

- Be sure to use crimped terminals for wiring terminals.
Use round terminals to prevent the crimped terminals from coming loose from the terminal on the CMC10B.
Use insulated covered crimped terminals.
Prevent crimped terminals from coming into contact with adjacent terminals.
- Check the terminal numbers before wiring.
- When wiring is finished, check the connections for any miswiring before turning the power ON.
- Ground the CMC10B at one point only (FG terminal). Do not ground the CMC10B using two or more terminals.
- When there are many shielded leads to ground, prepare a separate ground terminal plate (earth bar):
 Ground type: less than 100Ω
 Ground lead: Annealed conductive lead of 2mm² or more (AWG14)
 Ground lead length: Max. 20m

■ **Connecting the Power Supply**

Connect the power terminal as follows:

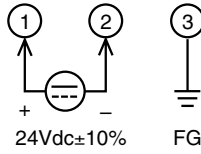

! **Handling Precautions**

Power is mutually connected between linked modules.
 Supply power to one of the linked modules.
 Select a power supply that can cover the total power consumption of all linked modules.

■ **Connecting Local CPL Communications**

Local CPL communications (RS-485) is performed using a 3-wire system.

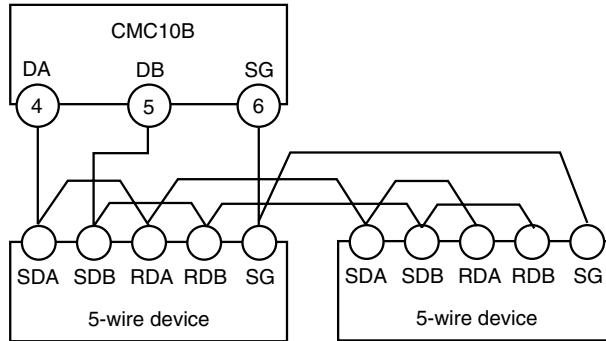

Example of connection with a 5-wire device

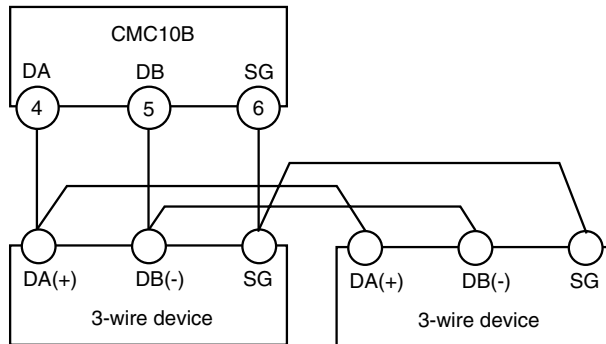

Example of connection with a 3-wire device

! **Handling Precautions**

Be sure to connect SG terminals each other.
 Failure to do so might cause unstable communications.

■ Connecting Host CPL Communications (HOST↔CMC)

Host CPL communications is performed using a connector.

The applicable connector is 81440792-001 (set of 4) MSTB2,5/5-STF-5,08 AU made by Phoenix Contacts Ltd. or equivalent product.

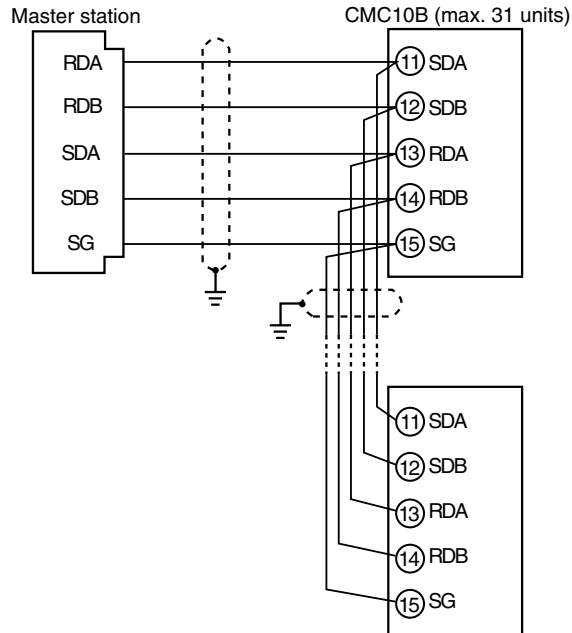

Example: Connection with a 5-wire device

⚠ Handling Precautions

Be sure to connect SG terminals each other.

Failure to do so might cause unstable communications.

Chapter 5. COMMUNICATIONS FUNCTIONS

5 - 1 Outline of Communications

■ Features

The features of the CMC10B's communications functions are as follows:

- Up to 31 local stations can be connected to a single CMC10B. (Local address of local station within the range 1 to 31)
- When the host and local devices are connected by the RS-232C interface, RS-232C/RS-485 conversion can be performed by the optional communications converter CMC10L.
- Random access commands are available for host communications. A single command enables reading and writing on parameters that are used as remote addresses.
- With the local station communications protocol, communications is performed using CPL protocol supported by the devices connected according to the Smart Loader Package setup.
- With local station communications, communications is performed using command types supported by the local station. This is achieved by setting up the type of the local station device on the Smart Loader Package SLP-CM1.
- Both the host and local stations support the maximum baud rate of 19200bps.

■ Defaults

The following setups are required for starting communications.
The table below shows the factory settings.

Item	Host Settings	Setting Location	Local Settings	Setting Location
Local address	00 (*) to 99	Rotary switch	~	~
Baud rate	0: 4800bps (*) 1: 9600bps 2: 19200bps	Rotary switch	0: 4800bps 1: 9600bps 2: 19200bps (*)	Smart Loader Package
Data format	0: 8bit, even parity, 1 stop bit (*) 1: 8bit, no parity, 2 stop bits	Smart Loader Package	0: 8bit, even parity, 1 stop bit (*) 1: 8bit, no parity, 2 stop bits	Smart Loader Package

* Factory setting

■ Reception and Transmission Timing of Messages

● Host side

Period	Time Required
Message interpretation time	Min. 1ms
Transmission driver enable from completion of reception on this device	Min. 1ms
Driver disable from completion of transmission of this device's response message	Min. 1ms
Next message receivable state from completion of transmission of this device's response message	Max. 2ms.
Wait time required from completion of host station reception to next message transmission	Min. 10ms

● Local side

Set the timeouts according to the requirements and limitations of each connected device.

5 - 2 Message Structure

■ Message Structure

The following show the message structure.

Messages are broadly classified into two layers:, the data link layer and the application layer.

- Data Link Layer
This layer contains the basic information required for communications such as the destination of the communications message and the check information of the message.
- Application Layer
Data is read and written in this layer. The content of the data varies according to the purpose of the message.

Messages comprise parts (1) to (9) in the figure below.

The command (details sent from the host) and the response (details returned from the local station) are stored in the application layer.

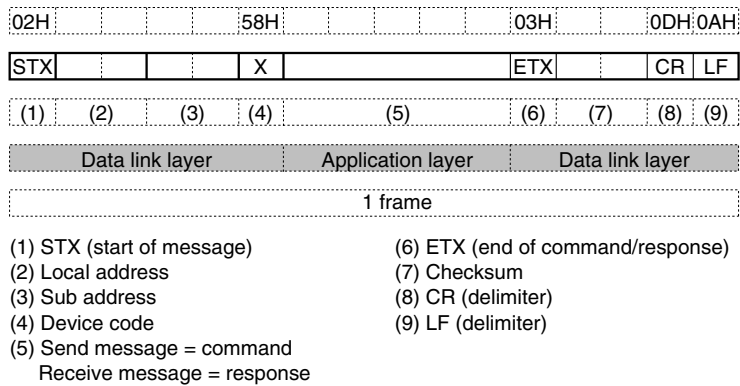

■ Data Link Layer

● Outline

The data link layer is of a fixed length. The position of each data item and the number of its characters are already decided. Note, however, that the data positions of the data link layer from ETX onwards shift according to the number of characters in the application layer. The character length, however, remains unchanged.

● Response start conditions

- The device sends the response message only when (1) message structure, (2) local address, (3) sub address, (4) checksum and (5) message length of a single frame in the data link layer are all correct. If even one of these is incorrect, no response messages are sent, and the device stands by for reception of STX.
- The maximum length of a single message is 256 characters.
- The maximum size of a single message is 256bytes.

● List of data link layer data definitions

The following list shows the definitions for data in the data link layer.

Data name	Character code	Number of Characters	Position from Start	Meaning of Data
STX	02H	1	0	Start of message
Local address	0 to 07FH are expressed as Hex character codes.	2	1, 2	Judgment of device to communicate with
Sub address	0 to 07FH are expressed as Hex character codes.	2	3, 4	See " Chapter 6 HOW TO USE THE CMC10B " (page 6-15).
Device code	"X" (58H) or "x" (78H)	1	5	Device type
ETX	ETX (03H)	1	5 + α + 0	End position of application layer
Checksum	00H to FFH are expressed as 2-digit Hex character codes.	2	5 + α + 1 5 + α + 2	Checksum of message
CR	0DH	1	5 + α + 3	End of message (1)
LF	0AH	1	5 + α + 4	End of message (2)

α : Number of characters in application layer

● Description of data items

- STX (02H)

When STX is received, the device judges this to be the start of the sent message. For this reason, the device returns to the initial state whatever reception state it was in until STX was received, and processing is started on the assumption that the STX of the first character has been received. The purpose of this is to enable recovery of the device's response at the next correct message (e.g. RETRY message) from the host in the event that noise, for example, causes an error in the sent message.
- Local address

Of the messages sent by the host, the device creates response messages only when local addresses are the same. Local addresses in messages are expressed as 2-digit hexadecimal characters.

The local address is set by the rotary switch on the front panel within the range 1 to 99 (01H to 63H).

When the local address is set to 0 (30H), the device judges no response even if local addresses match.

The device returns the same local address as that received as the response message.
- Sub address

To read and write directly to the local station from the host, set 01H to 1FH.

To read and write CMC10B data, set 00H.

For details, see "**■ To Directly Read and Write to the Local Station from the Host**" (page 6-15).
- Device code

The device sets X(58H) or x(78H) as the device code. This code is determined for each device series, and other codes cannot be selected. The device returns the same device code as that received as the response message. X(58H) is used as the default, and x(78H) is used for judging the message as the resend message.
- ETX

ETX indicates the end of the application layer.

- Checksum
This value is for checking whether or not some abnormality (e.g. noise) causes the message content to change during communications.
The checksum is expressed as two hexadecimal characters.
- How to create the checksum
 1. Add the content of the message from STX through ETX in single byte units.
 2. Take 2's complement of the addition results.
 3. Convert the result to character codes.
- CR/LF
This indicates the end of the message. Immediately after LF is received, the device immediately stands by for permission to process the received message.

■ Application Layer

The table below shows the configuration of the application layer.

Item	Description
Command	"RS" (read decimal number format continuous address data command)
	"WS" (write decimal number format continuous address data command)
	"RD" (read hexadecimal number format continuous address data command)
	"WD" (write hexadecimal number format continuous address data command)
	"RU" (read hexadecimal number format continuous address data command)
	"WU" (write hexadecimal number format continuous address data command)
Data delimiter	"," (comma) for RS and WS commands No data delimiter for RD, WD, RU and WU commands
Data address	Expressed as decimal with W (e.g. 501W) for RS and WS commands Expressed as 4-digit hexadecimal for RD, WD, RU and WU commands
Number of reads	Numerical value of characters expressed as "1" for example
Number of writes	Numerical value of characters expressed as "100" for example

5 - 3 Description of Commands

■ Read Continuous Data Command (RS command)

This command reads the data of continuous addresses as a single command.

● Send message

This instruction enables the content of continuous data addresses starting with the specified read start address to be read as a single message. The figure below shows the structure of the application layer of the send message when the data is read.

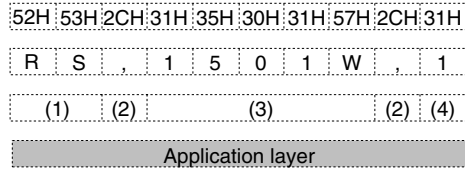

- (1) Read command
- (2) Data delimiter
- (3) Word address
- (4) Read data

● Response message

A response message corresponding to the command content is returned when the message is correctly received. The read data is always one type as the number of read data items is limited.

The figure below shows the structure of the application layer of the response message when the data is read.

- At normal termination (reading of single data item)

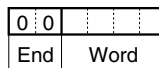

- At normal termination (reading of multiple data items)

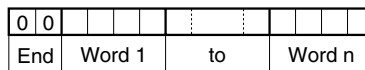

- At abnormal termination

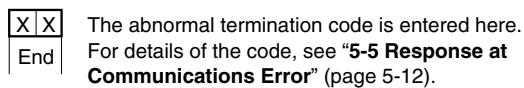

● Maximum number of read data items per message

Host: 32 words

■ Write Continuous Data Command (WS command)

This command writes data to continuous addresses.

● Send message

The figure below shows the structure of the application layer of the send message for the data write instruction.

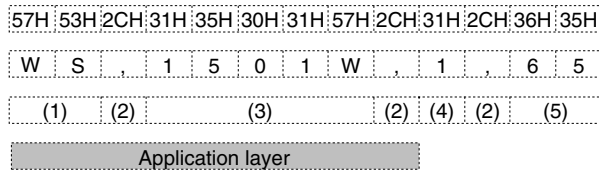

- (1) Write command
- (2) Data delimiter
- (3) Start write word address
- (4) Write data (1st word)
- (5) Write data (2nd word)

● Response message

The figure below shows the structure of the application layer of the response message for the data write instruction.

- At normal completion



- At abnormal completion or warning

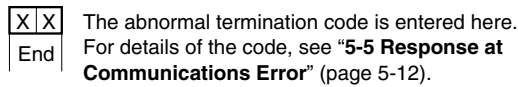

● Maximum number of write data items per message

Host: 32 words

■ **Read Continuous Fixed Length Data Command (RD command)**

This command reads continuous data in 2-byte units. This command is suited to handling of data in ladder programs sent by PLC communications as the data is of a fixed length.

The start data address is expressed as four hexadecimal digits. The number of data items is expressed as four digits, and data is expressed as four x n (n is a positive integer) hexadecimal digits.

● **Send message**

The read start data address (four or eight hexadecimal digits) and the number of read data items (four hexadecimal digits) are sent.

R	D						
Type	Data address				Number of data items		

● **Response message**

If the message is sent successfully, the termination code is taken to be normal (two decimal digits), and the termination code is returned appended with the number of read data (four hexadecimal digits x number of read data items) specified by the command. If message transmission ends in error, the termination code is taken to be in error (two decimal digits), and the read data is returned without any information appended.

Note, however, that when the data is in a format (4-byte integer, floating decimal point, etc.) that necessitates use of an area of two data items or more, the read data is continuous by the amount of required area.

● **At normal termination (reading of single data item)**

0	:	0				
End	Word					

● **At normal termination (reading of multiple data items)**

0	:	0					:				
End	Word 1		to				Word n				

● **At abnormal termination**

X	:	X				
End	The abnormal termination code is entered here. For details of the code, see "5-5 Response at Communications Error"(page 5-12).					

● **Maximum number of read data items per message**

Host: 60 words

■ **Write Continuous Fixed Length Data Command (WD command)**

This command writes continuous data in 2-byte units. This command is suited to handling of data in ladder programs sent by PLC communications as the data is of a fixed length.

The start data address is expressed as four hexadecimal digits. Data is expressed as four x n (n is a plus integer) hexadecimal digits.

● **Send message**

The write start data address (four or eight hexadecimal digits) and the number of write data items (four hexadecimal digits) are sent. Note, however, that when the data is in a format (4-byte integer, floating decimal point, etc.) that necessitates use of an area of two data items or more, the write data must be continuous according to the amount of required area.

● Writing of single data item

W:D							
Type	Data address		Word				

● Writing of multiple data items

W:D									
Type	Data address		Word 1	to		Word n			

● **Response message**

If writing is successful, the normal termination code (two decimal digits) is returned. If only part of the data is written, and the remaining data is not written, the warning terminal code (two decimal digits) is returned. If none of the data is written, the abnormal termination code (two decimal digits) is returned. If the data is in a format that necessitates use of an area of two data items or more and there is not enough data for the area, that data is not written.

● At normal termination

00
End

● At abnormal termination or warning

XX	The abnormal termination code is entered here.
End	For details of the code, see “5-5 Response at Communications Error” (page 5-12).

● **Maximum number of write data items per message**

Host: 60 words

■ Read Fixed Length Random Data (RU command)

This command reads random (non-continuous) data in 2-byte units.

● Send message

The data address (four or eight hexadecimal digits) of the data to be read is sent in the specified order. Note, however, that this command cannot be used when the data is in a format (4-byte integer, floating decimal point, etc.) that necessitates use of an area that is not 2-byte units.

R	U	0	0																
Type	Sub	Data address 1				to	Data address n												

Sub-commands are fixed at 00.

● Response message

If the message is sent successfully, the termination code is taken to be normal (two decimal digits), and the termination code is returned appended with the number of read data (four hexadecimal digits x number of read data items) specified by the command. If message transmission ends in error, the termination code is taken to be in error (two decimal digits), and the read data is returned without any information appended.

● At normal termination

0	0																		
End	Word 1				to	Word n													

● At abnormal termination

X	X	The abnormal termination code is entered here. For details of the code, see "5-5 Response at Communications Error" (page 5-12).																	
End																			

● Maximum number of read data items per message

Host: 60 words

5 - 4 Numeric Representation in the Application Layer

Each of the numerical values in the application layer must be expressed with zero suppressed.

The table below shows specifications, including those obtained when zero suppression is not performed. Data in send messages at the host must be sent with all zeros suppressed.

● Handling of numerical values and signs

Item	Specifications	Error Processing
Numerical value part/sign part	<ul style="list-style-type: none"> The plus sign "+" must not be appended. "-" is appended to express minus numbers. 	Message processing is aborted, and only termination code "99" is returned as the response message.

● RS and WS commands

Item	Specifications	Error Processing
Unwanted spaces	Cannot be appended.	Message processing is aborted, and only the abnormal termination code is returned as the response message.
Unwanted zeros	Error processing is not performed even if unwanted zeros are appended to the start of the numerical value if the number of digits including the numerical value part (including the minus sign) is seven digits.	
Numerical value=zero	Cannot be omitted. "0" is always used.	
Other unwanted characters	Can be appended to the start of numerical values having the minus sign "-". Other characters cannot be appended. "+" must not be appended in the case of positive numerical values.	
Range of usable numerical values	-32768 to +32767 This range must not be exceeded.	

● RD, WD, RU and WU commands

Item	Specifications	Error Processing
Unwanted spaces	Cannot be appended.	Message processing is aborted, and only the abnormal termination code is returned as the response message.
Unwanted zeros	Be sure to append "0" so that number of digits is four.	
Numerical value=zero	Cannot be omitted. "0000" is always used.	
Other unwanted characters	Cannot be appended.	
Range of usable numerical values	0000H to FFFFH Unsigned/signed varies according to definition of write destination.	

5 - 5 Response at Communications Error

The termination code is returned as the response message when an error occurs on the application layer.

Description of Error	Processing	Example	Termination code
Undefined command	Only termination code is returned, and message processing is not performed.	AA, 1001W, 1 RX03E80001	99
Value of written data out of range	Processing is continued excluding relevant word address.	WS, 2001W, 3000	22
Writing impossible by device setting value conditions	Processing is continued excluding relevant word address.		23
Number of read words in error, number of write words in error	Only termination code is returned, and message processing is not performed.	RS, 1001W, A WD03E9000Z	10
Word address out of range • Conversion error Range -32768 to +32767 exceeded	Only termination code is returned, and message processing is not performed.	RS, 10000W, 1 WD0XXX0001	21
The number of data items is greater than the maximum number of reads or the maximum number of writes	Only termination code is returned, and message processing is not performed.	RS, 1000W, 50	20



Note

The table above shows the termination code generated by the communications error which occurred in the communication between the host and the CMC10B. For the termination code generated by the communication error which occurred in the communication between the CMC10B and the slave, see Termination code of buffer data area (page 6-10).

Chapter 6. HOW TO USE THE CMC10B

6 - 1 Using the CMC10B For the First Time

This section describes the procedure up to reading of buffered data using an easy setup. The CMC10B is set up by the Smart Loader Package SLP-CM1 for the CMC10B.

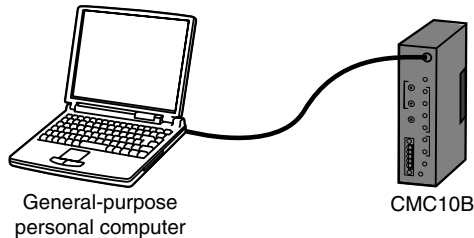

Set up the following items:

- Communications conditions with host (host communications HOST \leftrightarrow CMC)
- Communications conditions with local station (local communications CMC \leftrightarrow LOCAL)
- Parameters for buffering local station data

The following describes how to set up the above items in the presented order.

! Handling Precautions

Each of these setups are enabled by turning the CMC10B ON again or by restarting the CMC10B at the RESET switch. After setting up these items, be sure to either turn the CMC10B back ON again or press the RESET switch.

■ Host Communications Setup

The conditions for communicating with the host are set up using the rotary switch on the CMC10B or in the Smart Loader Package program.

● Setting by rotary switch

- Local address
Set the CMC10B's local address within the range 01 to 99. The factory setting is 00. When the local address is set to 00, the CMC10B does not return a response even if local addresses match.
- Baud rate
Set the baud rate to the same value as the other devices connected to the host. Set within the range 0 to 2. The factory setting is 0 (4800bps).

Position	Baud rate
0	4800bps
1	9600bps
2	19200bps

● **Setting by Smart Loader Package**

- Data format

Set the data format using the Smart Loader Package (SLP-CM1) program for the CMC10B.

Start up the Smart Loader Package program, and click [Setup] → [Communication] → [Host].

>> The following screen is displayed:

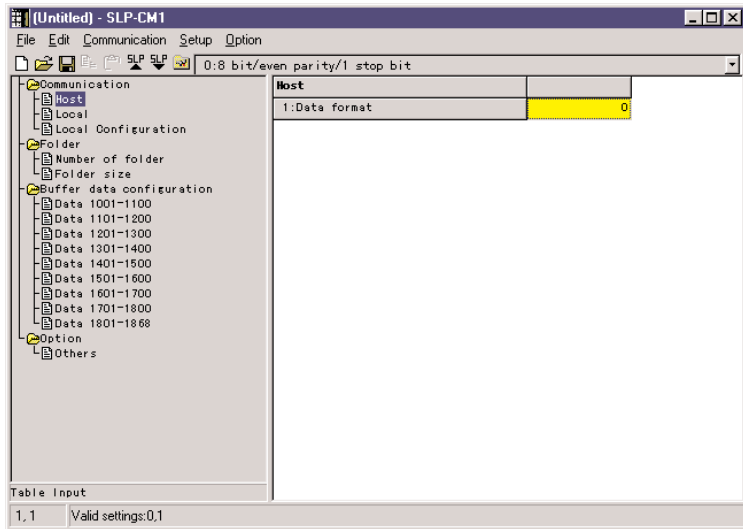

Select either of the following data formats:

- 0: 8bit/even parity/1 stop bit
- 1: 8bit/no parity/2 stop bits

Set the data format to the same value for the devices currently connected to the host.

■ Local Communications Setup

Set the communications parameters of the local station.

Click [Setup] → [Communication] → [Local] in the Smart Loader Package program.

>> The following screen is displayed:

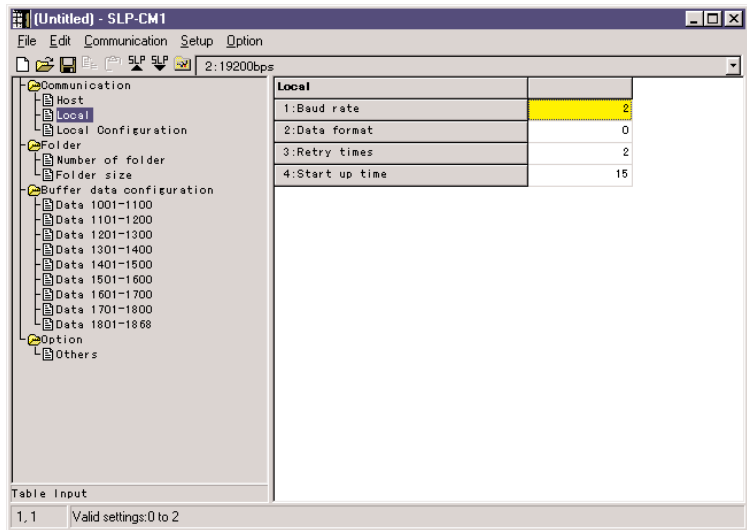

● Baud rate

Set the baud rate to the same value as that for devices currently connected to the local station within the range 0 to 2. The factory setting is 2 (19200bps).

Select one of the following for 1: Baud rate:

- 0: 4800bps
- 1: 9600bps
- 2: 19200bps

● Data format

Select either of the following for 2: Data format:

- 0: 8bit/even parity/1 stop bit
- 1: 8bit/no parity/2 stop bits

Set the data format to the same value as that for devices currently connected to the local station.

! Handling Precautions

Leave 3: Retry times and 4: Start up time at [Local] at their factory settings. These items need not be set to new values.

For details on these settings, see “**■ Adjusting the Response Time with the Local Station**” (page 6-18).

Local Assignments

In addition to the parameters for setting the communications conditions and common settings for the local station, set parameter items unique to each of the connected local stations (that is, for each local address).

In the Smart Loader Package program, click [Setup] → [Communication] → [Local Configuration].

>> The following screen is displayed:

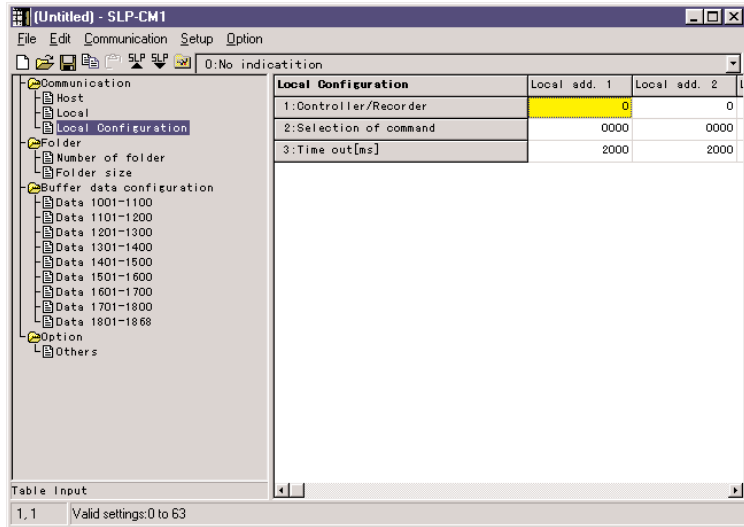

Set the local address of the local station within the range 1 to 31. Values outside of this range cannot be assigned as the local address.

Set the following items in addition to the local address of the devices connected to the CMC10B.

1: Controller/Recorder

Select this item when the list box contains a same model No. as the currently connected device.

It is easier to enter buffer data assignment data if model Nos. match.

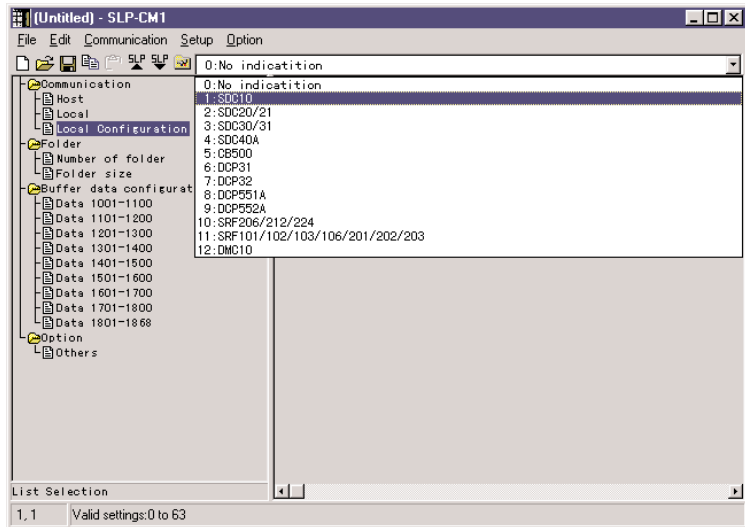

If the list box does not contain an identical model No., select 0: Other.

2: Selection of command

Set this item according to the type of command and access data length supported by the connected devices. Data is expressed in hexadecimal and is set within the range 00H to 3FH.

When a model is selected at 1: Controller/Recorder, the setup suitable for that model No. is automatically set. Setup data cannot be changed at this time.

Bit assignments are as follows:

Bit	Command
0 to 1	RS command (0: 1 word only, 1: up to eight words can be accessed, 2: up to 16 words can be accessed, 3: up to 32 words can be accessed)
2 to 3	RD command (0: not supported, 1: up to 16 words can be accessed, 2: up to 28 words can be accessed, 3: up to 60 words can be accessed)
4 to 5	RU command (0: not supported, 1: up to 8 words can be accessed, 2: up to 16 words can be accessed, 3: up to 28 words can be accessed)

Any value can be selected when 0: Other is selected.

Either directly enter a value in hexadecimal, or select [Edit] menu → [Bit input] to display the [Bit input] window. Select the desired value in this window.

[Bit input] Setup Examples

(1) When the device supports only 1-word RS commands:

Mark only bit0 as the RS command accesses only in 1-word units, and click the

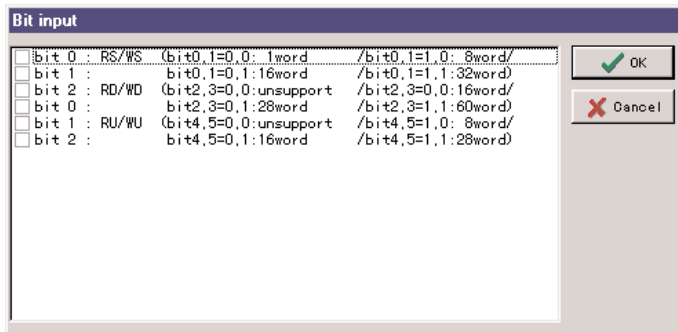

[OK] button.

When entering data directly, enter “1”.

(2) When the device supports 16-word RS commands and 28-word RD and RU

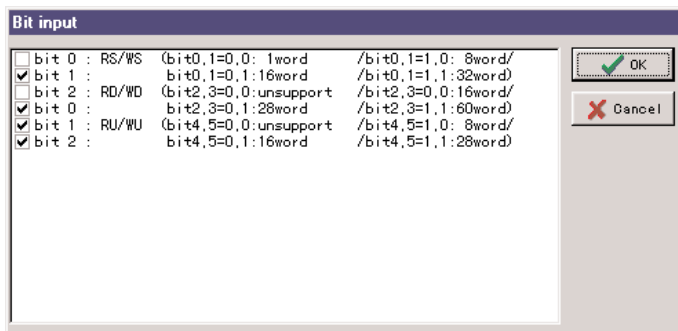

commands:

Mark bit1, bit3, bit4 and bit5, and click the [OK] button.

When entering data directly, enter “3A”.

For details on the command types of other devices, refer to the Communications instructions Manual for the device.

3. Time out

This item need not be set to a new value. Leave it at its factory setting. For details, see “**■ Adjusting the Response Time with the Local Station**” (page 6-18). Factory setting is 2000.

■ Folder Setup

The size of the buffer data area is determined by the number of folders and the sum of the sizes (number of data items) of each folder.

For example, assuming that the number of folders is two and the sizes of folder No.1 and No.2 to be 100 and 50, then the size of the buffer data area is 150 (100 + 50).

The maximum size of the buffer data area is 868 words, and up to 32 folders can be set.

Although the size of each folder can be set within the range 1 to 868 words, prevent the sum of the sizes of each valid folder from exceeding 868 words.

In this section, let's describe a simple examples assuming the size of the buffer data area to be 30 (1 as the number of folders, and 30 as the size of folder No.1).

For details on an example where multiple folders are set, see “**■ To Quickly Update Specific Data**” (page 6-12).

● Setting the number of folders

In the Smart Loader Package program, click [Setup] → [Folder] → [Number of folder].

>> The following screen is displayed:

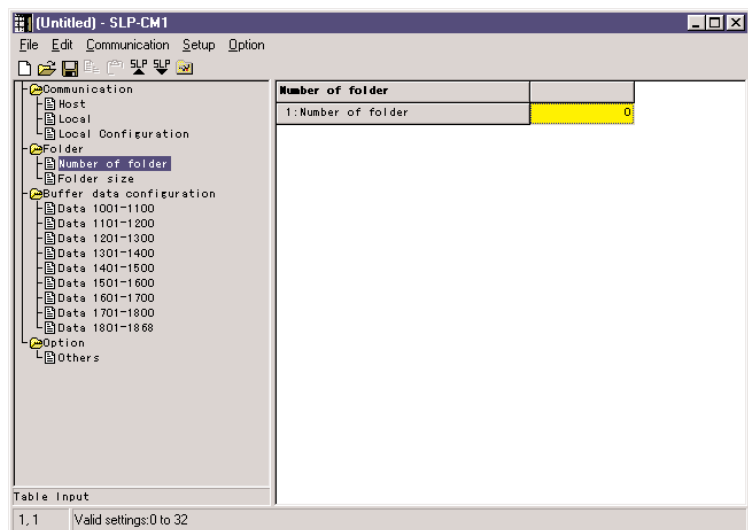

1: Number of folder

Set the number of folders within the range 0 to 32. In this example, let's enter “1”.

In the Smart Loader Package program, click [Setup] → [Folder] → [Number of folder].

● Folder size

1: Folder size

Set the folder size within the range 1 to 868, and enter the number of items to be buffered. In this example, let's enter "30".

Enter data for the folder size for the number of folders entered at 1: Number of folder.

In this example, 1: Number of folder is set to "1" so "----" is displayed for data of the second row onwards for the folder size as the data is invalid.

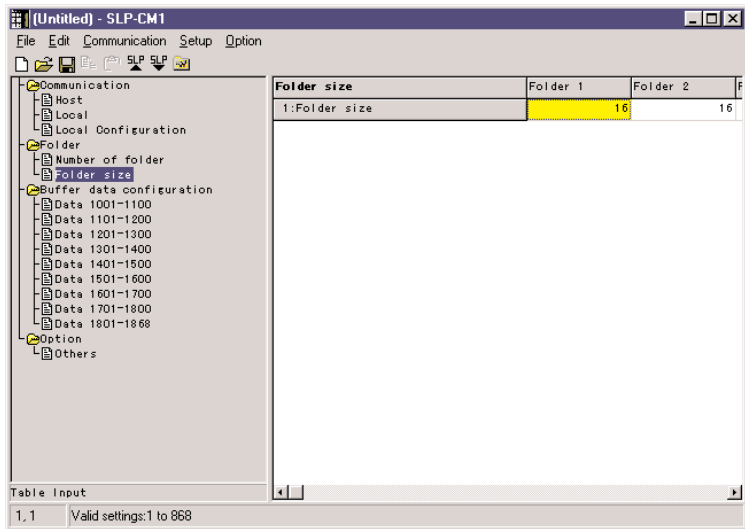

When the number of folders is 0, 2: Folder size is not displayed.

Note

To check the size of the buffer data, set the above data, turn the CMC10B OFF then ON again (or restart the CMC10B by pressing the RESET switch), and read the buffer data area of CPL address: word 400.

■ Buffer Data Configuration

At this item, set the local address to be accessed (read or written) for each of the buffer data items and the read (write) addresses of the devices.

Also set up R/W enable/disable for limiting accessing of local addresses to read-only or write-only as necessary.

1: Local Address

Set the local address within the range 1 to 31. Enter the address of the device to be buffered.

2: Data address

Set the data address within the range 0 to 32767. Enter the read (write) address of the device.

An Easy Way of Entering the R/W Address

If a model No. of a connected device is selected from the list box when assigning a local station, you can select the main data addresses from the list box when entering the data address.

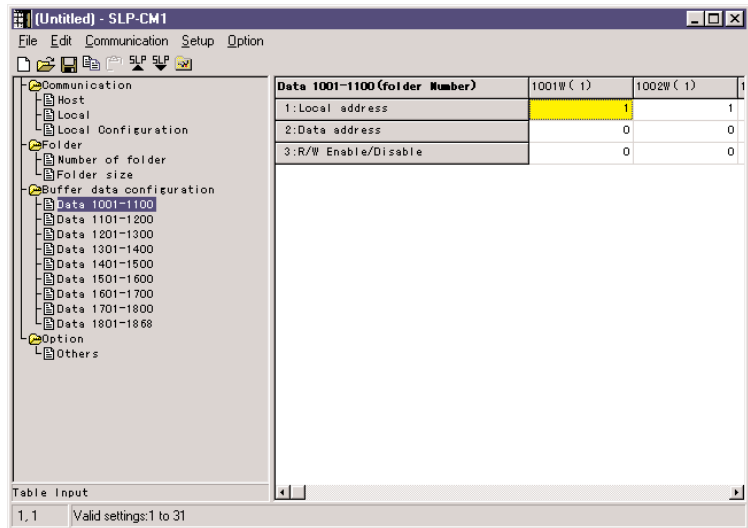

Note

For details on R/W enable/disable, see “**To Disable Reading and Writing of Specific Buffered Data**” (page 6-15).

As Number of folder is set to “1” and the size of folder No.1 is set to “30” at “Folder”, set up 30 buffer data items here.

In the Smart Loader Package program, click [Setup] → [Buffer data configuration] → [Data 1001-1100].

Display the data to be set.

Writing Setup Data to the CMC10B

Write the data set up on the Smart Loader Package program to the CMC10B.

Select [Communication] menu → [Write (SLP → CMC10B)] and click the [OK] button.

When you have finished writing data, click the [OK] button to exit this procedure.

Handling Precautions

To enable the setup, either turn the CMC10B OFF then ON again, or restart the CMC10B by pressing the RESET switch.

Saving Setup Data

To save the data set up in the Smart Loader Package program, select [File] menu → [Save As], set [Save in] and [File name], and click the [Save] button.

■ **Reading Buffered Data**

The POWER LED blinks when the CMC10B is turned OFF then back ON again, or the CMC10B is restarted by pressing the RESET switch.

When the value set at [Local] → [Start up time] has elapsed, the POWER LED lights, and buffering is started.

● **Reading the buffer data (CPL address: words 1001 to 1868)**

Data is buffered successively to CMC10B word address: 1001 onwards.

This area is read when the host reads buffered data.

For example, assuming that 30 buffer data items are to be read, the data of word addresses 1001 to 1030 is read.

Data value 0 is read if buffer data is read before buffering is performed.

● **Monitoring the data on the Smart Loader Package**

In the startup screen of the Smart Loader Package program, click [Monitor] → [Monitor] → [Start].

Click the [OK] button.

● **Termination codes of buffer data area**

The termination code becomes 00 at a normal end when buffer data is read by CPL commands sent from the host.

The termination codes are as follows if there is no response from the local station, or the buffer data area is read before buffering is performed. The read data at this time becomes 0.

Termination code	Status of Local Device	Read data
00	Normal response	Normal data
81	No response from local station	Fixed at "0"
82	Data error	Fixed at "0"
84	Error response received from local station	Fixed at "0"
88	Buffering incomplete data	Fixed at "0"

Termination codes in the above table are expressed in hexadecimal.

The termination code for reading of multiple data items is the value obtained by the logical AND of the termination code (hexadecimal) of each data item.

For example, the termination code when the local station no-response data and data for which the error response was received are read is as follows:

$$81H \text{ OR } 84H = 85H$$

 **Note**

The table above shows the termination code generated by the communications error which occurred in the communication between the CMC10B and the slave. For the termination code generated by the communications error which occurred in the communication between the host and the CMC10B, see 5-5 Response at communications error (page 5-12).

6 - 2 Advanced Use of CMC10B Features

This section describes the setup method for writing buffered data or for performing buffering more efficiently.

■ To Write Data to Multiple Local Stations

To write data to multiple local stations, the device issues the write command successively to the local stations when write data is sent to the buffer data area in a single operation.

If the host sends the command in a single operation to the CMC10B, there is no need to send the write command to all local stations.

To write data to local stations, set up the parameters (local address and write address) to the buffer data area.

The parameter setup is the same as that described in “■ Buffer Data Configuration” (page 6-8).

● Buffer data area write command

CPL addresses: words 1001 to 1868 are allocated for the buffer data area. For example, the write command is sent to CPL address: word 1020 when the data to be written to the local station is buffer data No.20.

● Write command response timing

The response is sent to the host when the CMC10B is ready to send the data from the host to the local station. For this reason, writing to the local station has not yet been executed when the response has been returned to the host.

● How to confirm that writing to the local station has been executed

bit4 of the R/W enable/disable (CPL address: words 7001 to 7868) value turns ON when the CMC10B has accepted preparations for writing to the local station. bit4 then turns OFF when the write command to the local station is sent.

R/W Enable/Disable	Status
00H	Regular status
↓	↓
10H	Standby for writing to local station
↓	↓
00H	Write command executed to local station

For details on R/W enable/disable, see page 6-21.

Note

The data becomes the same value as the write data when the buffer data area is read when the CMC10B buffers this area after executing the write to local station command, and the data of the local station is written to the buffer area (CPL address: words 1001 to 1868).

● Writing non-defined buffer data

An error code is returned as the response when buffer data (e.g. data of No.401 when 400 words are allocated as the buffer area) outside of the defined buffer area is written.

● **Buffer write error information**

Buffer data area information (CPL addresses: words 901 to 904) is written to when CMC10B could not successfully execute writing to the local station (for example, when an error termination code was received from the local station, or there is no response from the local station).

CPL address	Description
901W	Status (0: Regular/1: Error generated)
902W	Local address of local station that sent the write command
903W	Write address to local station
904W	Error response code received from local station*

* 88H indicates that there is no response from the local station.

When multiple writing is performed and multiple error termination codes are returned, the buffer data area is written to for each erroneous termination. For this reason, the latest error information is written to this area. The content of words 902 to 904 is cleared to 0 (zero) by writing “0” to word 901.

■ **To Quickly Update Specific Data**

The CMC10B has a buffer area having a maximum size of 868 words. When the buffer data area contains a lot of data, and you want to quickly update only specific data, the buffer data area can be divided into several folders, each of which can be assigned priority during data updates.

● **To set multiple folders**

When the number of folders is set to “1” in the parameters as described in the previous item, all data is updated at the same cycle.
To update data giving priority only to specific data and not update all data uniformly, divide the buffer data area by units called “folders.”

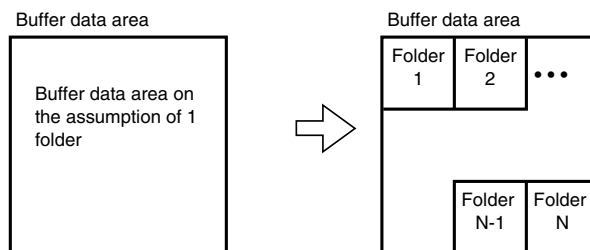

“■ **Folder Setup**” (page 6-7) describes an example where the number of folders is set to “1” and the size of folder No.1 is set to “30”. The following describes an example where the buffer data area is divided into three folders. In this case, the size of each of folders No.1 to No.3 is 10.

In the Smart Loader Package program click [Setup] → [Folder] → [Number of folder].

Enter “3” at 1: Number of folder.

In the Smart Loader Package program click [Setup] → [Folder] → [Folder size].

Enter “10” for all three folders at 2: Folder size.

! Handling Precautions

Even if the content of the data is changed in the folder setup, there is no need to set the buffer data configuration settings (1 to 30) again.

The size of the data area is determined by the number of folders and size of folders. The folders need not be set to the same size. (For example, the sizes of folders No.1 to 3 may be 5, 15 and 10, respectively.)

● Buffering modes

Data is updated in single folders, one at a time. This item describes how to update data.

There are three buffering modes as follows.

- Buffering all folders

In this mode, all folders are updated successively from folder No.1. When updating of the data in folder No.1 ends, updating of the data in folder No.2 is started. When updating of the data in all folders specified as the valid number of folders ends, the updating sequence returns to folder No.1 and updating starts again.

This is the default buffering mode after the CMC10B is turned ON.

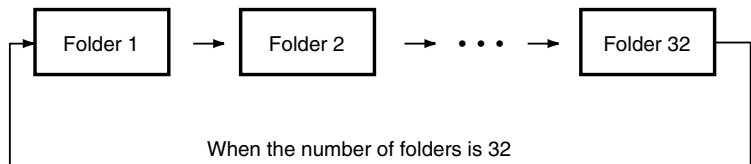

- Buffering selected folders

In this mode, only selected folders are updated. Folders not selected are skipped during updating.

Selected folders: 1, 2 and 3

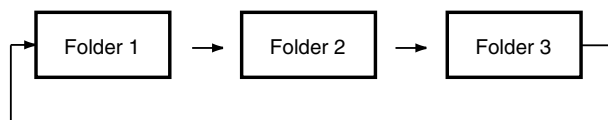

- Buffering selected folders + 1

In this mode, data in folders is updated in the same way as in the buffering selected folders mode except that data in another folder at the end of the folder update sequence is updated.

In this mode, select two types of folders: folders that are updated every time at each update operation and the folder at the end of the folder update sequence.

Selected folders: 1 and 2
Plus 1 folder: 4 and 5

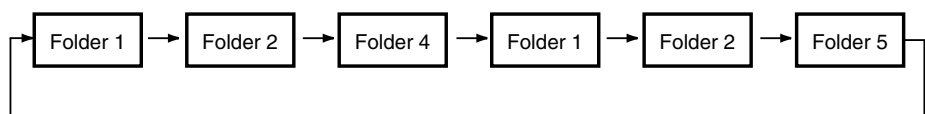

- How to change the buffering mode

Use CPL command to change the buffering mode.

Word address on CMC10B: 801

Data 0: Stopped

1: Buffering all modes

2: Buffering selected folders

3: Buffering selected folders + 1

! Handling Precautions

- When data: 2 is selected, the selected folder at words 802 or 803 must be set up.
- When data: 3 is selected, the selected folder at words 802 or 803, and the + 1 folder at words 804 or 805 must be set up.
- This setting is enabled only when the power is ON. When the CMC10B is turned OFF then back ON again, this setting returns to 1: Buffering all modes. To change to another mode, set the desired mode after turning the CMC10B ON.

- Selected folder

Word address on CMC10B: 802 to 803

Set the folders to be updated at each update operation for the buffering selected folder mode or the buffering selected folder + 1 mode.

Set folders No.1 to No.16 at word 801 and folders No.17 to 32 at word 802.

- Data format

Data range: 0000H to FFFFH (in decimal, -32768 to +32767)

Add the corresponding bit to the specified folder according to table below.

For example, the data is as follows when specifying folders No.1, 2 and 4.

$$1 + 2 + 8 = 16$$

The data is as follows when specifying folders No.1, 2, 15 and 16.

$$1 + 2 + 16384 + (-32768) = -16381$$

Word 802

Selected Folder	Data
Folder No.1	1
Folder No.2	2
Folder No.3	4
Folder No.4	8
Folder No.5	16
Folder No.6	32
Folder No.7	64
Folder No.8	128
Folder No.9	256
Folder No.10	512
Folder No.11	1024
Folder No.12	2048
Folder No.13	4096
Folder No.14	8192
Folder No.15	16384
Folder No.16	-32768

Word 803

Selected Folder	Data
Folder No.17	1
Folder No.18	2
Folder No.19	4
Folder No.20	8
Folder No.21	16
Folder No.22	32
Folder No.23	64
Folder No.24	128
Folder No.25	256
Folder No.26	512
Folder No.27	1024
Folder No.28	2048
Folder No.29	4096
Folder No.30	8192
Folder No.31	16384
Folder No.32	-32768

- + 1 folder selection

Word address on CMC10B: 804 or 805

Set up folder to be updated at the end of the folder update sequence after the folder (content of words 802 or 803) that is updated every time at each update operation has been updated.

Set folders No.1 to No.16 at word 804 and folders No.17 to 32 at word 805. The data format is same as that for the folder selection at word 802 or 803.

● Changing the buffering mode on the Smart Loader Package

In the Smart Loader Package program startup screen

(1) Click [Monitor] → [Option] menu → [Folder mode].

(2) The [Folder mode] window opens. Click the list box at the top left, select the buffering mode and mark the folder to be selected.

(3) Click the [OK] button.

■ To Directly Read and Write to the Local Station from the Host

Read and write commands can be sent from the host to local stations (or stations subordinate to the CMC10B when viewed by a host such as a controller) connected to the CMC10B.

● How to send commands

Sub-address values 01H to 1FH in the CPL command frame are sent to the local addresses of the local station (station subordinate to CMC10B when viewed from the host) connected to the CMC10B. The application layer becomes the command to the local station.

Note

Commands from the host whose sub-address is “00” or “F0” are commands to the CMC10B.

When the sub-address is neither of these values, the command is for local stations connected to the CMC10B.

■ To Disable Reading and Writing of Specific Buffered Data

Depending on the application, some buffer data is targeted only for writing (that is, the data need not be read).

Overall buffering efficiency can be improved by disabling buffering of write-only data and enabling buffering of only specific required data.

Another way of improving overall buffering efficiency is to group write-only data in a folder and set a buffering mode so that this folder is not updated. This is described in the previous item.

Note, however, that reading of write-only data must be disabled when a folder for the write-only data cannot be created, for example, when the maximum number of folders is already exceeded.

- **How to set read disable/write disable**

In the Smart Loader Package program

- (1) Click [Setup] → [R/W Enable/Disable] for the data to be set at [Buffer data configuration].
- (2) Select R/W enable or disable from the list box window.

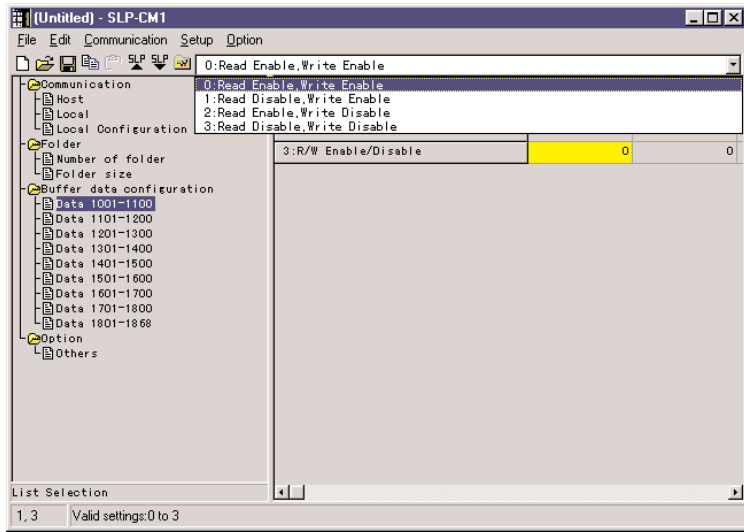

- **Reading read-disabled buffer data**

The value buffer data becomes “0” (zero) when the buffer data is set as read-disabled.

- **Writing (buffering) to write-disabled area**

A normal code is returned in response to commands for writing to buffer data that is set as write-disabled. Note, however, that writing to the local station is not performed in this case.

■ Selecting LED Indicator Lamp Functions

The CMC10B has six LED indicator lamps.

- **POWER LED**

The POWER LED blinks when the CMC10B is turned ON up to before buffering is started. When buffering is started, the POWER LED lights.

Note, however, that the POWER LED stays blinking if buffering is set not to be performed in the setup (for example, when the number of valid folders is “0” or the buffering mode is set to “Stopped”).

● ERR LED

Causes of lighting/non-lighting of the ERR LED (ERR LED lamp function) can be selected according to the following settings:

0	Out at all times
1	Lighting at any communication error
2	Lighting at host communication error
3	Lighting at local communication error
4	Lighting at Smart Loader Package communication error
5	Folder setup failure
6	Lighting at any abnormal termination code
7	Lighting at abnormal termination code to host
8	Lighting at abnormal termination code from local station
9	Lighting at abnormal termination code to Loader

Note) A communications error occurs when the baud rate or data format setting does not match that of the device that the CMC10B is to communicate with.

The ERR LED goes out when the cause of the lamp lighting is no longer valid. For example, when the ERR LED lamp function is set to “8: Lighting at abnormal termination code from local station”, the ERR LED lamp lights when an abnormal termination code from the local station is received, and goes out when a normal termination code is received.

The factory setting is “8” (Lighting at abnormal termination code from local station).

Select the ERR LED lamp function as follows:

In the Smart Loader Package program

(1) Click [Setup] → [Option] → [Other] → [1: ERR LED].

(2) Select the desired ERR LED lamp function from the list box window.

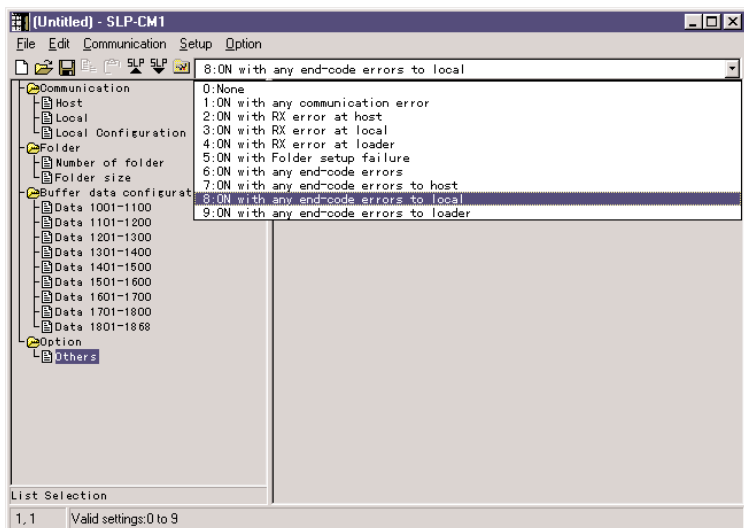

● Other LEDs

LEDs for reception and transmission are located on the host and local station.

■ Adjusting the Response Time with the Local Station

The CMC10B allows you to set up or change the buffering start time or time out during communications with the local station.

● Local station parameters

- Retry times

Set the number of retries until communications with a local station is forcibly stopped due, for example, to no response from the station during buffering of data. Set the number of retries within the range 0 to 2. The factory setting is 2.

Setup Method

In the Smart Loader Package program

- (1) Click [Setup] → [Communication] → [Local] → [3: Retry times].
- (2) Enter the desired number of retries.

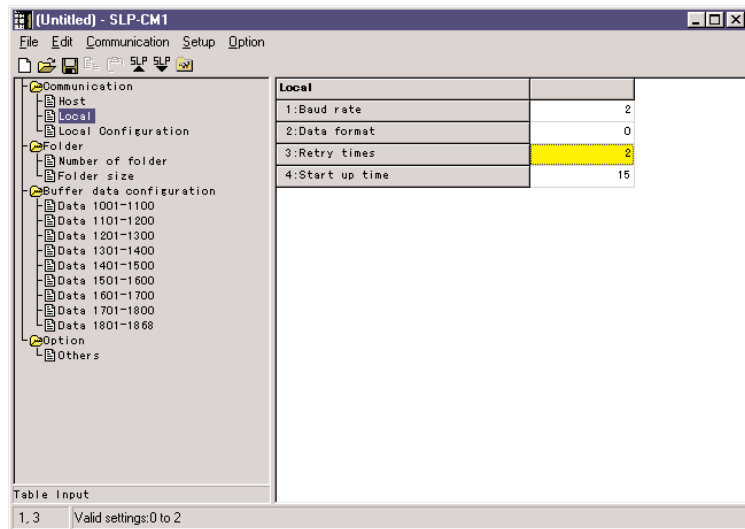

- Buffering start time

The “buffering start time” is the time from when the CMC10B is turned ON up to before buffering is started.

Set the buffering start time within the range 1 to 120s. The factory setting is 15s.

Setup Method

In the Smart Loader Package program

- (1) Click [Setup] → [Communication] → [Local] → [4: Start up time].
- (2) Enter the desired buffering start time.

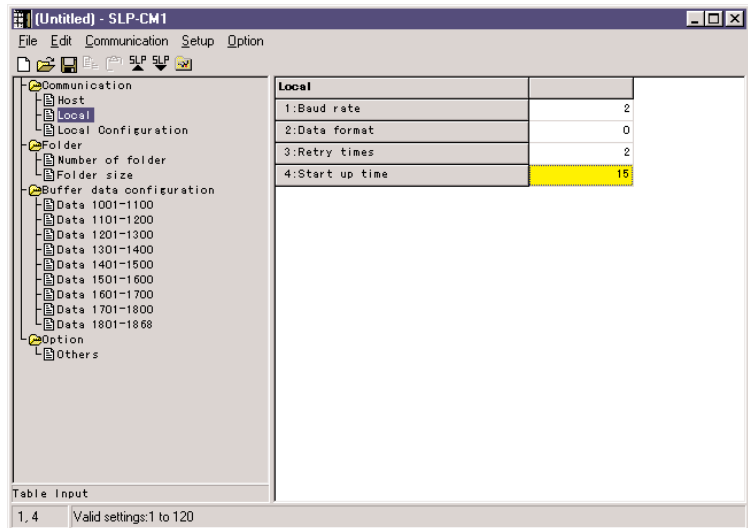

● Time out

Set the time out for when there is no response from the local station for each local address. Set the time out within the range 500 to 2000ms. The factory setting is 2000ms.

Setup Method

In the Smart Loader Package program

- (1) Display the local address to be set up at [Setup] → [Communication] → [Local Configuration].
- (2) Click [3: Time out [ms]].
- (3) Enter the desired time out.

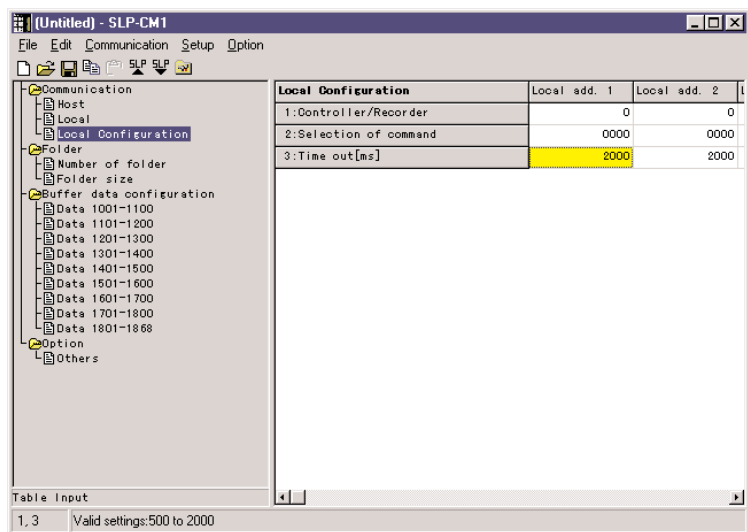

■ Checking the Buffering State

Termination code area (CPL address: words 6001 to 6868)

The termination code save area is the area for saving termination codes when the CMC10B buffers local station data.

You can find out whether data has been buffered successfully or not by referring the data saved in this area.

Data		Status
Decimal	Hexadecimal	
0	0	Normal termination
129	81	No response from location station
130	82	Receive data error
136	88	Outside buffer data area
Value other than above	Value other than above	Abnormal termination code received from local station

The data for an abnormal termination code from the local station is expressed in hexadecimal as 99. When this code is read as decimal format data, for example, by the RS command, the read data is expressed in decimal as 153.

● **Monitoring data on the Smart Loader Package**

In the Smart Loader Package program startup screen from the local station

- (1) Click [Monitor] → [Monitor] menu → [Address].
- (2) Mark the [Monitor item] → [Termination code area] checkbox in the [Monitor address selection] window.
- (3) Click the [OK] button.
Data is displayed in decimal.

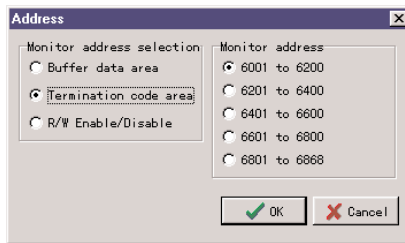

■ **Reading the Buffered Data Attributes**

R/W enable/disable buffered data attributes (CPL address: words 7001 to 7868)
 These attributes are read when verifying whether the buffered data already set is read/write-disabled or whether there is a buffering write request.
 Data is as follows:

Data	Status
bit 0	0: Read Enable 1: Read Disable
bit 1	0: Write Enable 1: Write Disable
bit 4	0: Buffering write request OFF 1: Buffering write request ON

the Smart Loader Package

In the Smart Loader Package program startup screen

- (1) Click [Monitor] → [Monitor] menu → [Address].
- (2) Mark the [Monitor item] → [R/W Enable/Disable] checkbox in the [Monitor address selection] window.
- (3) Click the [OK] button.

Data is expressed in decimal.

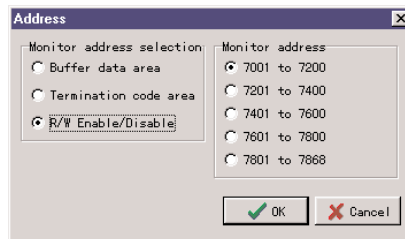

Monitoring data on

6 - 3 Other Smart Loader Package Functions

■ Checking the CMC10B Setup

To read the CMC10B setup, in the Smart Loader Package program startup screen click [Setup] → [Communication] menu → [Read (CMC10B→SLP)]. Then, click the [OK] button.

■ Other Smart Loader Package Functions

● Connection

Monitor whether or not communications can be performed with the device connected to the CMC10B's local station.

Monitor Method

In the Smart Loader Package program startup screen

(1) Click [Monitor] → [Option] menu → [Connection].

(2) Click the [OK] button.

>> The following screen is displayed:

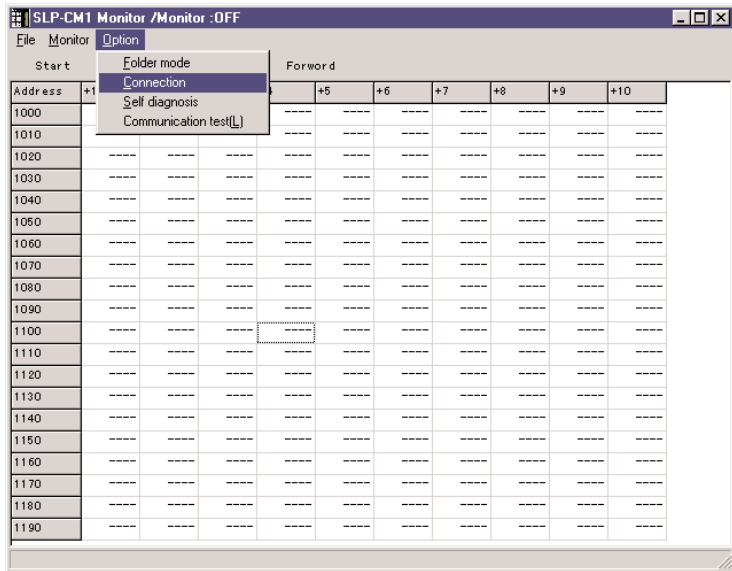

● Self diagnosis

Monitor the results of self diagnosis on the CMC10B.

Monitor Method

In the Smart Loader Package program startup screen

(1) Click [Monitor] → [Option] menu → [Self diagnosis].

(2) Click the [OK] button.

● Communication test

Use this item for sending CPL commands from the Smart Loader Package for the CMC10B.

By this test, you can also send commands to devices connected to the local station in addition to commands to the CMC10B.

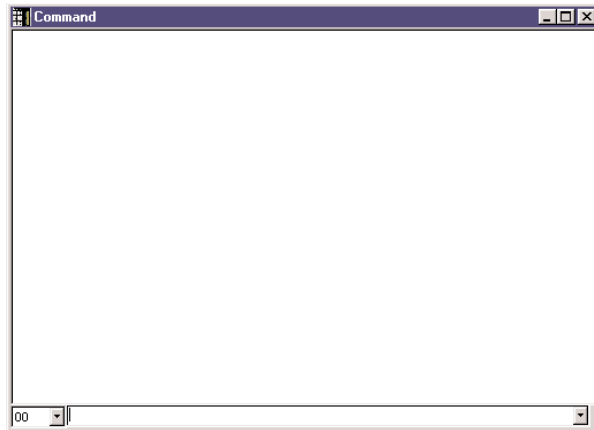

How to Send CPL Commands

In the Smart Loader Package program startup screen

- (1) Click [Monitor] → [Option] menu → [Communication test].
- (2) Enter the local address in the list box at the bottom left of the [Command] window. When "00" is entered, commands are sent to the CMC10B. To send commands to local stations, set to the same value (01 to 31) as the local address of the local station.
- (3) Enter the command in the list box at the bottom right of the [Command] window.
- (4) Press the Return key.

>> The following screen is displayed:

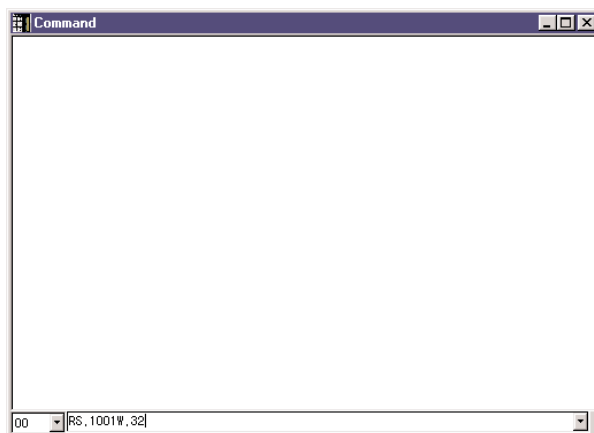

6 - 4 Data Lists

■ Loader Setting Lists

● Host communications conditions

Name	Default	Setting Range	Meaning of Setting	See Page
Data format	0	0: 8bit, even parity, 1 stop bit 1: 8bit, no parity, 2 stop bits	"Data bit length, parity, number of stop bits" setting in host communications	6-2

● Local station communications conditions

Name	Default	Setting Range	Meaning of Setting	See Page
Baud rate	2	0: 4800bps 1: 9600bps 2: 19200bps	Baud rate of local communications	6-3
Data format	0	0: 8 bit, even parity, 1 stop bit 1: 8 bit, no parity, 2 stop bits	"Data bit length, parity, number of stop bits" setting in local communications	
Retry times	2	0 to 2	Number of retries when communications does not end successfully by no response, for example, in local buffering	6-18
Buffering start time	15s	1 to 120	Time from power ON up to start of buffering	

● Folder setup

- Determine the buffer area size.

Name	Default	Setting Range	Meaning of Setting	See Page
Number of folder	0	0 to 32	Number of folders for dividing up buffer area	6-7
Folder size No.1 to 32	16	1 to 868	The size of the buffer area is determined by the sum of the size of the folders in Number of folder.	6-8 6-12

- Local configuration

Name	Default	Setting Range	Meaning of Setting	See Page
Local address 1/Device type	0	0 to 63	Identifies the device connected to the local station. Used by Smart Loader Package setup.	6-4 to 6-6
Command type	0	0 to 63	CPL command supported by device connected to local station Fixed by type (For details, see item 5.1.4.)	
Local address 1/Time out	2000ms	500 to 2000ms	Time out setup time for no response from local station	
Communications setup of local address 2	0 0 2000ms	0 to 63 0 to 63 500 to 2000ms	Same as local address 1 (501 to 505)	
Communications setup of local address 31	0 0 2000ms	0 to 63 0 to 63 500 to 2000ms	Same as local address 1 (501 to 505)	

- Buffer data configuration

Name	Default	Setting Range	Meaning of Setting	See Page
Buffer data 1/Local address	1	1 to 31	Local address of connected local station	6-8 6-15
Buffer data 1/Data address	0	0 to 32767	Read/write address for accessing device of connected to the local station	
Buffer data 1/ R/W enable/disable	0	0 to 3 Bit 0: Read disable Bit 1: Write disable	Used for disabling reading or writing of buffering data.	
Buffer data n/Setup	1 0 0	1 to 31 0 to 32767 0 to 3	Same as buffer address 1 (3001 to 3003)	6-8 6-15
Buffer data 868/Setup	1 0 0	1 to 31 0 to 32767 0 to 3	Same as buffer address 1 (3001 to 3003)	

● Other settings

Name	Default	Setting Range	Meaning of Setting	See Page
ERR LED definition	8	0: Out at all times 1: Any error in all reception 2: Host communication error 3: Local communication error 4: Loader communication error 5: Folder setup failure 6: Any abnormal termination code in all communications 7: Abnormal termination code to host 8: Abnormal termination code from local station 9: Abnormal termination code to Smart Loader Package	Selects lighting/out conditions of ERR LED (red).	6-17

■ CPL Address Map

● Buffered data

Name	CPL address	Data Range	Meaning	See Page
Buffer data area	1001 to 1868	-32768 to +32767	Stores data when buffering is performed from the local station.	6-10
Termination code save area	6001 to 6868	0: Normal 129: No response 130: Receive data error 136: Buffer no execution Others: Abnormal termination code	Termination code of response command from the local station during buffering. Value is fixed when communications is not established by no response, for example.	6-10
Buffer data R/W Enable/Disable	7001 to 7868	Bit 0: Read disable Bit 1: Write disable Bit 4: Writing requested	Indicates the read/write disable attributes. Bits are set when there is a write request.	6-21

● Reading buffer-written status

Name	CPL address	Data Range	Meaning	See Page
Buffer write information	901	0: Normal or no execution 1: Buffer write error	Values of 901 to 904 become 0 when 0 is written to this area that is set at error generation.	6-12
Write error station number	902	1 to 31	Local address of the local station where error occurred	
Write error address	903	0 to 32767	Write address of the local station where error occurred	
Write error code	904	0: Normal 129: No response 130: Receive data error 136: Buffer no execution Others: Abnormal termination code	Abnormal termination code from the local station where error occurred	

● **Total size of buffer data area**

Name	CPL address	Data Range	Meaning	See Page
Buffer area definition	401	0 to 868	Size of buffer data determined by folder setup	6-7

● **Selecting the buffering mode**

- Buffering mode

Name	CPL address	Data Range	Meaning	See Page
Folder buffering mode	801	0: Stop buffering 1: Buffering all folders 2: Buffering selected folders 3: Buffering selected folders + 1	Type of folder buffering	6-13

- Details of selected folders

Name	CPL address	Data Range	Meaning	See Page
Content of selected folder (No.1 to 16)	802	-32768 to +32767	Selects folder (No.1 to 16) to be buffered at selected folder buffering.	6-13
Content of selected folder (No.17 to 32)	803	-32768 to +32767	Selects folder (No.17 to 32) to be buffered at selected folder buffering.	
Content of plus 1 folder selection (No.1 to 16)	804	-32768 to +32767	Selects plus 1 folder (No.1 to 16) to be buffered at selected plus 1 folder buffering.	
Content of plus 1 folder selection (No.17 to 32)	805	-32768 to +32767	Selects plus 1 folder (No.17 to 32) to be buffered at selected plus 1 folder buffering.	

Chapter 7. TROUBLESHOOTING

7 - 1 Communications Is Not Possible

■ Buffered Data Cannot Be Read

LED display			Status	Cause and Remedy	See Page
POWER	LOCAL	RD			
●	○	○	Folder setup failure	The total size of enabled folders is either 0 or exceeds 868. → Review the folder setup, number of folders or folder size setup.	6-7
			Folder buffering stopped	Folder buffering mode is "Stopped." Enabled folders are not designated to selection content in selected folder or plus 1 mode. → Set the folder buffering mode and selection content again.	6-12
			Data read inhibited	Buffer data assignments and R/W enable/disable settings are set to "Read disable." → Set to "Read enable."	6-15
●	●	○	Communications parameter mismatch	Communications parameters of CMC10B and local station do not match. → Set the local station setup again.	6-3
			Local address mismatch	Command is being issued to different local address. → Set the buffer data management setup and local address setup again.	6-4
			Time out generated	The local station time out is set to a time earlier than the local station response time. → Return to default 2000.	6-19
			Cable not connected	Cable miswiring and broken lead. → Check connections.	Chapter 4
●	○	○	Data read disabled	Buffer data assignments and R/W enable/disable settings are set to "Read disable." → Set to "Read enable."	6-15
●	●	●	Abnormal termination	Abnormal termination code was received from local station due to wrong read address. → Set buffer data assignments and address setup again.	6-8
			Abnormal termination	Abnormal termination code was received as transmission was performed by command type not supported by the local station. → Set local station assignments and command type again, or return to default 0.	6-5

Meaning of symbols in the LED display column

- : Blinking
- : Out
- : Lit

■ Buffered Data Cannot Be Written

LED display			Status	Cause and Remedy	See Page
POWER	LOCAL				
ER	SD	RD			
●	○	○	Data write disable	Buffer data assignments and R/W enable/disable settings are set to "Write disable." → Set to "Write enable."	6-15
●	●	●	Abnormal termination	Abnormal termination code was received from local station due to wrong write address. → Set buffer data assignments and address setup again.	6-8
			Abnormal termination	Abnormal termination code was received as transmission was performed by command type not supported by the local station. → Set local station assignments and command type again, or return to default 0.	6-5

■ Communications With Host Not Possible

LED display			Status	Cause and Remedy	See Page
POWER	LOCAL				
ER	SD	RD			
●	○	○	Communications parameter mismatch	Communications parameters of CMC10B and host do not match. → Set the host setup and rotary switch B.RATE setup again.	6-1
			Local address mismatch	Command is being issued to different local address. → Set the rotary switch CMC ADDRESS setup again.	6-1
			Cable not connected	Cable miswiring and broken lead. → Check connections.	Chapter 4

7 - 2 Debugging Examples

■ Checking Communications Parameters

● Check the host communications port

Set the ERR LED definition to the “Host communication error.”

Probable causes of the ERR LED lighting are baud rate or bit length mismatch.

● Check the local station communications port

Start up the communications status monitor.

Probable causes of an NG (No Good) status are baud rate or bit length mismatch, or wrong cable wiring.

Set the ERR LED definition to the “Local communication error”.

Probable causes of the ERR LED lighting is baud rate or bit length mismatch.

■ Checking Communications Termination Codes

● Check the host communications port

Set the ERR LED definition to “Abnormal termination code to host.”

A probable cause of the ERR LED lighting is that an error response was returned to the host from the CMC10B. Check the commands.

● Check the local communications port

Set the ERR LED definition to “Abnormal termination code from local station.”

A probable cause of the ERR LED lighting is that an error response was received from the local station. Check the commands.

Set the ERR LED definition to “Abnormal termination code to host.”

A probable cause of the ERR LED lighting is that an error response was returned to the host from the CMC10B. Check the commands.

■ Checking on Monitor

- Buffer data area
Check the content of the buffered data.
- Termination code save area
Normal response
If there is no response or the received data is in error, check the state of the connections.
If an abnormal termination code is returned, check the write address.
- R/W Enable/Disable
Check the read/write enable/disable states.

■ Self diagnosis

Checksum at power ON: NG

→ Countermeasure: Reset the CMC10B after writing with the Smart Loader Package again.

Checksum after power ON: NG

→ Countermeasure: Reset the CMC10B after writing with the Smart Loader Package again.

Total size of folder: NG

→ Countermeasure: Check the number of folders to delete and the size of each folder.

! Handling Precautions

If the result is still NG even after resetting the CMC10B, a probable cause is that the CMC10B is malfunctioning. Please contact Yamatake Corporation or your dealer.

Chapter 8. SPECIFICATIONS

■ Communications Specifications

	Item	Specifications
Host communications HOST↔CMC	Communications system	Half duplex
	Synchronization	Start-stop synchronization
	Transfer route type	Bus type (RS-485 compliant: 5-wire type)
	Connection type	1: N (max. 31 units)
	Baud rate	19200/9600/4800bps
	Transmission distance	Max. 500m
	Data format	8bit/even parity/1 stop bit or 8bit/no parity/2 stop bits
	Connector	Model No.: 81440792-001 (4 per set, sold separately)
Local communications HOST↔ CMC	Communications system	Half duplex
	Synchronization	Start-stop synchronization
	Transfer route type	Bus type (RS-485 compliant: 3-wire type)
	Connection type	1: N (max. 31 units)
	Baud rate	19200/9600/4800bps
	Transmission distance	Max. 500m
	Data format	8bit/even parity/1 stop bit or 8bit/no parity/2 stop bits
	Local address	1 to 31 (local station address)
Smart Loader Package communications	Loader exclusive for the CMC10B	Smart Loader Package: SLP-CM1E20 (sold separately) including loader connector cable exclusive for the CMC10B

■ General Specifications

Item		Specifications
Rated power voltage		24Vdc
Operating power voltage		21.6 to 26.4Vdc
Power consumption		5W (in operating state)
Insulation resistance		Min. 50MΩ by 500Vdc megger (across case or ground terminal and power terminal)
Dielectric strength		500Vac, 1m (across case or ground terminal and power terminal)
Isolation		<p> ——— Solid line: isolated - - - Dotted line: not isolated </p>
Operating conditions	Ambient temperature	0 to 50°C
	Ambient humidity	30 to 90%RH
Transport/storage conditions	Storage temperature	-20 to +70°C
	Storage humidity	10 to 95%RH
	Vibration resistance	Max. 4.9m/s ²
	Impact resistance	Screw mount: max. 392m/s ² DIN rail mount: max. 196m/s ²
	Package drop test	Drop height 60cm, free fall
Screw tightening torque	Connector for host communications connection	Terminal: 0.8N•m Mount: 0.8N•m
	Power and local communications terminal	0.8 to 1N•m
Mounting		Screw mount or DIN rail mount
Mask/case	Mask/case material	Mask: polycarbonate Case: polycarbonate Base: polycarbonate
	Mask/case color	Mask: navy blue Case: light gray Base: light gray
Standard accessories (User's Manual)		CP-UM-5129E CMC10B Communication Controller (CPL/CPL Converter)
Separate accessories (User's Manual)		CP-SP-1064E CMC10B Communication Controller (CPL/CPL Converter) Design manual
Mass		300g

● Optional parts (sold separately)

Part	Model No.	Description
Connector set	81440792-001	Connector set for host communications connection (4 per set)
Loader exclusive for the CMC10B	SLP-CM1E20	Smart Loader Package for Communication Controller CMC10B (CPL/CPL Converter) (including loader connector cable)

External Dimensions

Unit: mm

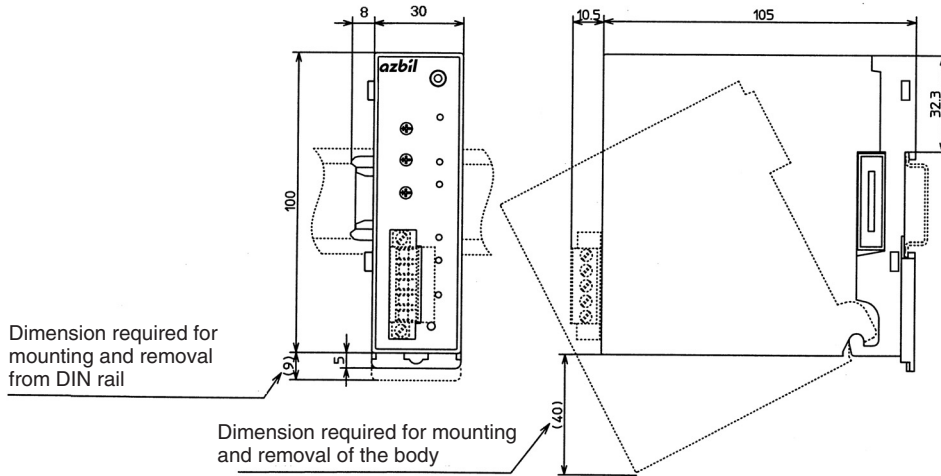

Index

	[Number]	
3-wire device	4-2	
5-wire device	4-2	
	[A]	
application layer	5-2, 5-4	
	[B]	
baud rate	5-1	
baud rate setup switch	2-1	
buffer data area	6-7	
buffer data area of CPL address	6-8	
buffer data configuration	6-8	
buffer write error	6-12	
buffered data, Reading	6-10	
buffering all folders	6-13	
buffering modes	6-13	
buffering mode, Changing the	6-14	
buffering selected folders + 1	6-13	
buffering selected folders	6-13	
	[C]	
cable used	4-1	
checksum	5-3	
communication parameters of the local stations	6-3	
communication test	6-22	
communications disconnection switch	2-1	
communications error	5-12	
configuration	1-1	
connection	6-22	
CPL Address Map	6-26	
CPL communications	1-1	
CR/LF	5-3	
	[D]	
data format	5-1	
data link layer	5-2	
defaults	5-1	
device judgement code	5-3	
DIN rail, Securing on a	3-2	
DIN rail locking tab	2-1	
DMC10	1-1	
	[E]	
ERR LED	6-17	
ETX	5-3	
	[F]	
folder size	6-8	
	[H]	
host communications setup	6-1	
host CPL communications	4-3	
host CPL communications connector	2-1	
	[I]	
installation procedure	3-2	
	[L]	
LED indications	2-2	
lever	2-1	
linking modules	3-1	
loader jack	2-1	
local address	5-1, 5-3	
local address setup switch	2-1	
local assignments	6-4	
local CPL communications, connecting	4-2	
local CPL communications terminal	2-1	
local station parameters	6-18	
	[M]	
message structure	5-2	
mounting locations	3-1	
	[N]	
number of folder	6-7	
	[P]	
POWER LED	6-16	
power supply, Connecting the	4-2	
power supply terminal	2-1	
	[R]	
R/W enable/disable	6-21	
RD command	5-7	
read continuous data	5-5	
read continuous fixed length data	5-7	
read fixed length random data	5-9	
reception and transmission timing of messages	5-1	
reset switch	2-1	
response start conditions	5-2	
retry times	6-18	
rotary switch	6-1	
rotary switch - Baud rate, Setting by	6-1	
RS command	5-5	
RS-485	4-2	
RU command	5-9	
	[S]	
save	6-9	
self diagnosis	6-22	
setup items	6-1	
STX	5-3	
sub address	5-3	
	[T]	
termination code save area	6-20	
time out	6-6, 6-19	
	[W]	
WD command	5-8	
write	6-9	
write continuous data	5-6	
write continuous fixed length data	5-8	
write data to multiple local stations, to	6-11	
write fixed length random data	5-10	
WS command	5-6	
WU command	5-10	
	[Z]	
zero suppression	5-11	

Revision History

Printed Date	Manual Number	Edition	Revised pages	Description
00-06	CP-SP-1064E	1st Edition		
01-08		2nd Edition	8-2	Fonts changed Weight → Mass changed
08-03		3rd Edition	3-1 3-2 4-2, 4-3 5-12 6-10	■ Mounting Locations changed. Handling Precautions added. Handling Precautions added. Note added. Note added.

azbil

Specifications are subject to change without notice.

Yamatake Corporation
Advanced Automation Company

1-12-2 Kawana, Fujisawa
Kanagawa 251-8522 Japan

URL: <http://www.azbil.com>

Printed on recycled paper. (07)

Printed in Japan.
1st Edition: Issued in June 2000(W)
3rd Edition: Issued in Mar. 2008(G)