

SDC25 / 26 Quick Reference Guide

This guide offers a summary of key operations, parameter flowcharts, and settings, for convenient reference at the operation site. This guide is made for repeated use. Dirt wipes off easily and even notes written with an oil-based felt-tip pen can be removed with an eraser. If more detailed information on the SDC25/26 is needed, refer to the user's manual: CP-SP-1149E for installation and configuration.

The most convenient way to configure the SDC25/26 is with the Smart Loader Package (model No. SLP-C35J50). Please contact Yamatake Corporation or a distributor for more information.

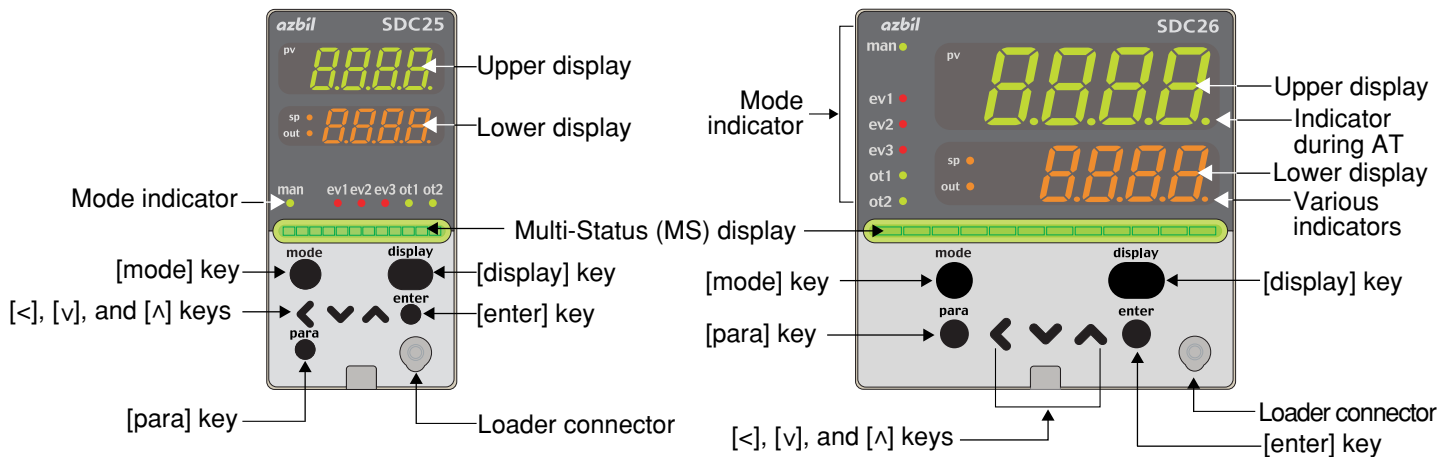

Upper display	This display shows either the PV value or the display value and set value for each displayed item. If an alarm is triggered, the normal display and alarm code are displayed alternately. During auto tuning (AT), the rightmost decimal point flashes twice repeatedly.
Lower display	This display shows either the SP/MV/CT or the display value and set value for each displayed item. Depending on the settings, the rightmost decimal point lights up, flashes, etc. to show RUN/READY mode or communications status.
Multi-Status (MS) display	Turns ON in READY mode or when an alarm occurs, depending on the ON conditions and the current status. When lit, in addition to flashing and reciprocating between left and right, it performs MV graph, DI monitor, internal event monitor, and other display functions.
Mode indicators	man: Lights when MANUAL (AUTO mode if not lit) ev1, ev2, ev3: Lights when event relays are ON ot1, ot2: Lights when the control output is ON (always lit when the current output is used)
[mode] key	<ul style="list-style-type: none"> When this key is pressed and held for more than 1 second in the operation display mode, any of the following operations from 0 to 7 which have been set previously can be executed 0 : Mode key does not operate (Initial value) 1 : AUTO/MANUAL mode selection 2 : RUN/READY mode selection 3 : AT (Auto Tuning) start/stop selection 4 : LSP (Local SP) group selection 5 : Release all DO (Digital Output) latches 6 : Mode key does not operate 7 : ON/OFF selection of communication DI <ul style="list-style-type: none"> When pressing the [mode] key in the setup display mode, the display is changed to the operation display
[display] key	This key is used to change the display item in the operation display mode. When pressing this key in the bank selection, bank setup, or user function setup display mode, the display is changed to the operation display.
[para] key	When this key is kept pressed for 2 sec. or longer in the operation display mode, the display is then changed to the setup display.
[<], [v], [^] keys	These keys are used to increase or decrease the numeric value, or to shift the digit. The [v] and [^] keys are used to change the bank or display item.
[enter] key	This key is used to begin changing settings (display goes from lit to flashing) and to finalize new settings (display goes from flashing to steadily lit).
Loader connector	This connector is used for connecting to a personal computer using the dedicated cable supplied with the Smart Loader Package.

Flowchart of key operations and displays

When the power is turned ON



[display] key
Upper and lower displays remain off for 5s after power ON. Each mode indicator lights sequentially, and then the operation display appears.

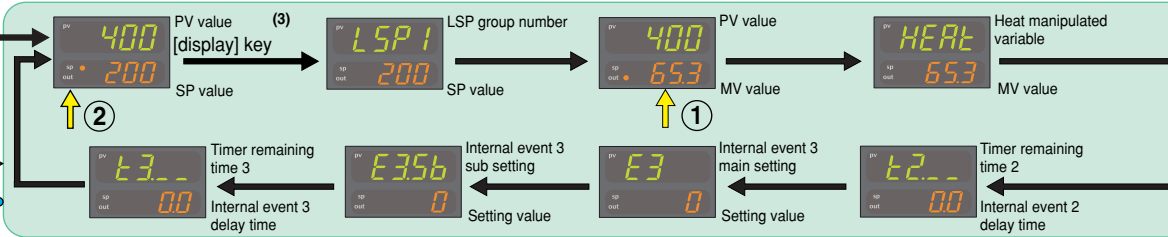

[display] key
User function

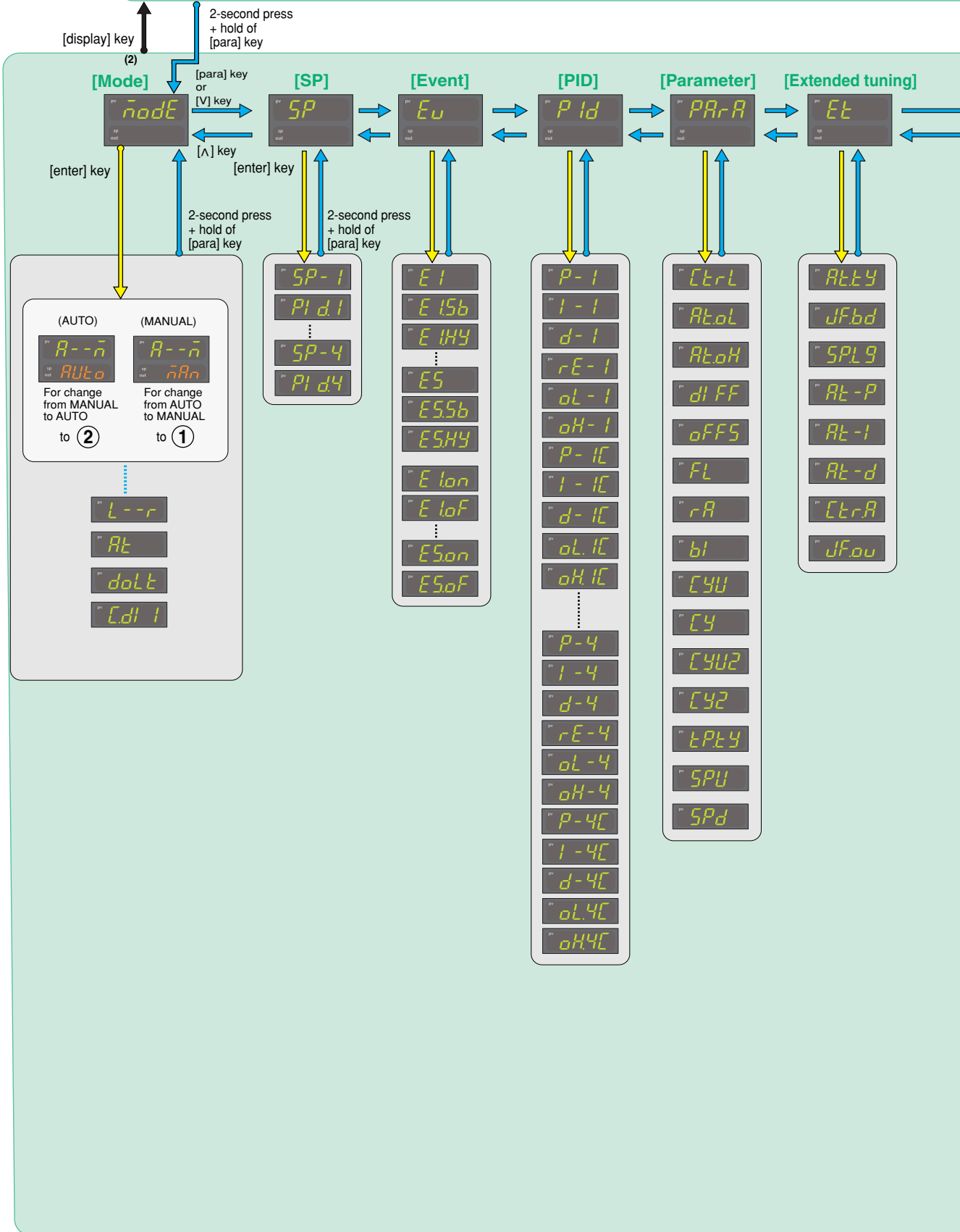
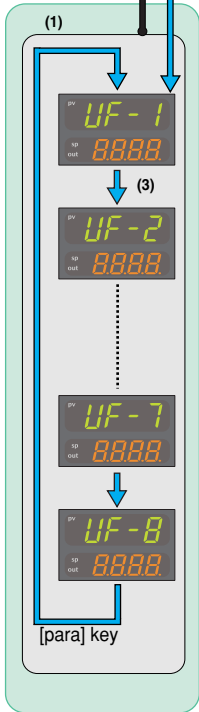

- Some items are not displayed depending on the availability of optional functions, model number, display setup (C73 to C78) and display level (C79).
- Pressing [display] while bank item or user function item is displayed has the effect of canceling and returning to the operation display item.

Operation displays

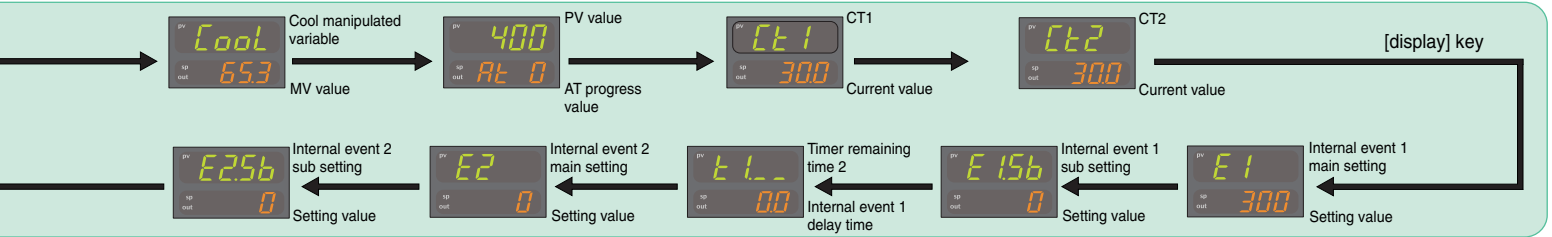

Bank selection

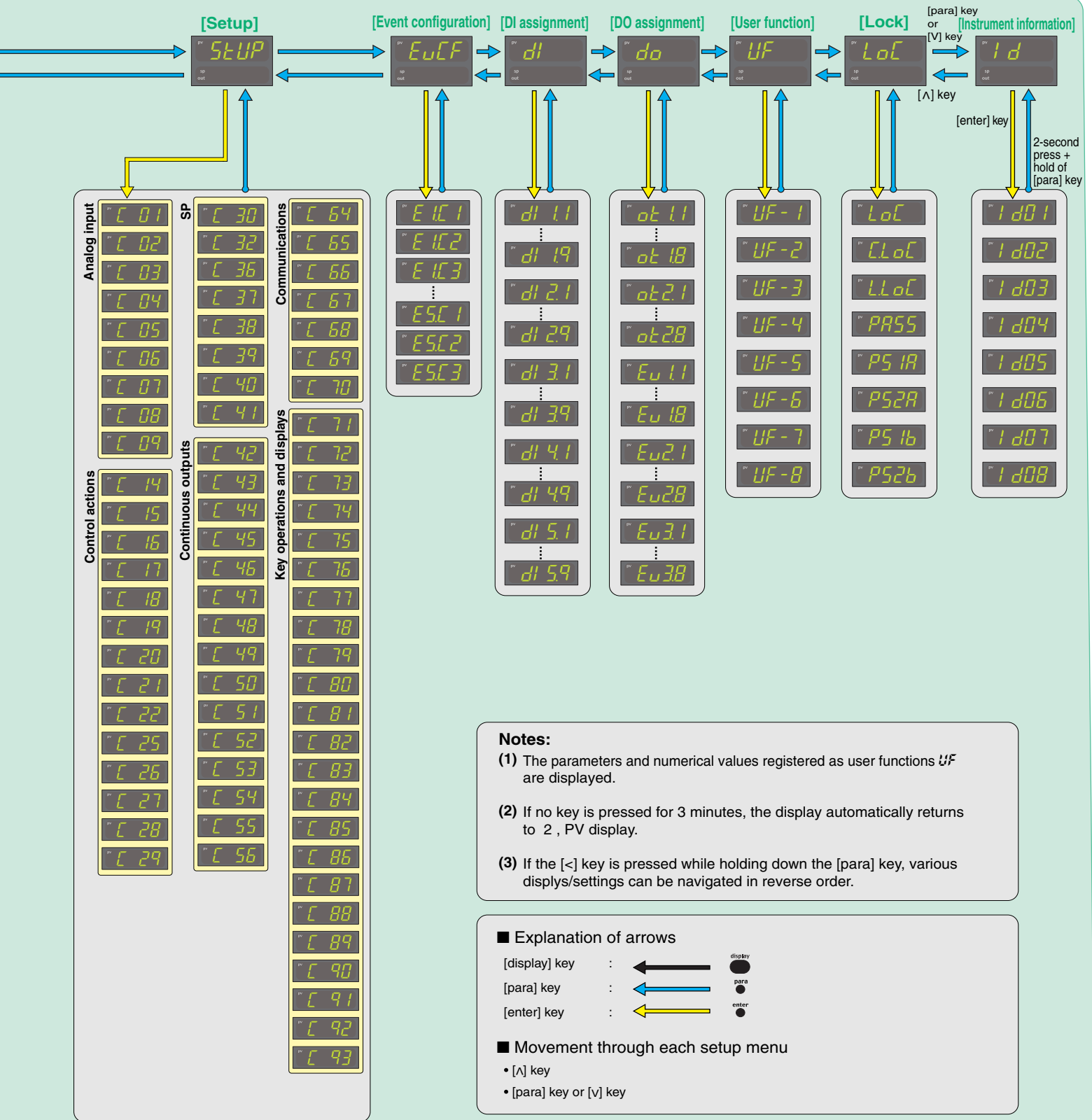

- Notes:**
- (1) The parameters and numerical values registered as user functions *UF* are displayed.
 - (2) If no key is pressed for 3 minutes, the display automatically returns to 2, PV display.
 - (3) If the [<] key is pressed while holding down the [para] key, various displys/settings can be navigated in reverse order.

Explanation of arrows

[display] key : ← (black arrow)

[para] key : ← (blue arrow)

[enter] key : ← (yellow arrow)

Legend: ● display, ● para, ● enter

Movement through each setup menu

- [Λ] key
- [para] key or [v] key

Operation examples





Red letters

: Items before operation

Blue letters

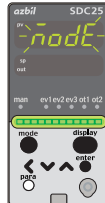





: Items during operation

Setup of PV input range type

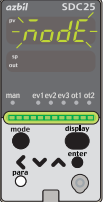
<p>1 Press [display] once to get the operation display.</p> 	<p>2 Press and hold [para] for more than 2s to get the parameter setup display. node flashes on the upper display.</p> 
<p>3 Press [v] or [Λ] repeatedly, and SELP flashes on the upper display.</p> 	<p>4 Press [enter]. The current set value for 01 (PV input range type) is displayed.</p> 
<p>5 Press [enter]. The rightmost digit on the lower display flashes and its value can be changed. Press [←], [v] or [Λ] to change to the desired sensor type in the PV input range list. Then press [enter] to finalize your selection. (If the number is flashing, the [enter] key has not yet been pressed, and the setting has not yet been saved.)</p> 	







Execution of auto tuning (AT)

AT forces ON/OFF of the MV a number of times (a limit cycle) to calculate PID values. Check that this operation does not create any problems for the associated equipment before executing AT.

<p>1 Press [display] once to get the operation display.</p> 	<p>2 Press and hold [para] for more than 2s to get the parameter setup display. node flashes on the upper display.</p> 	
<p>3 Press [enter] or [←] to get R--n on the upper display and Rto on the lower display.</p> 	<p>4 Press [v] as needed until Rt and RtoF appear on the upper and lower displays respectively.</p> 	
<p>5 When [enter] is pressed, RtoF flashes on the lower display.</p> 		<p>6 Press [v] or [Λ] once, and RtoF flashes on the lower display.</p> 
<p>7 If [enter] is pressed, Rton remains steadily lit and AT begins. During AT, the rightmost decimal point flashes twice repeatedly. (When AT is done, the light goes off and the new PID values go into effect.)</p> 		





Setup of event operation type

In this example, the event 1 operation type is set to deviation high limit.

<p>1 Press [display] once to get the operation display.</p> 	<p>2 Press and hold [para] for more than 2s to get the parameter setup display. node flashes on the upper display.</p> 
<p>3 Press [v] or [Λ] repeatedly to get EUCF flashing on the upper display.</p> 	<p>4 Press [enter] to get E1C1 on the upper display and 0 is displayed on the lower display.</p> 
<p>5 When [enter] is pressed, the rightmost digit on the lower display flashes. Press [v] or [Λ] to get 4 flashing on the display.</p> 	
<p>6 Press [enter], and the displayed value 4 on the lower display changes from flashing to continuously lit and the displayed value is set.</p> 	

Similarly, use **E2C1** to set the event 2 operation type, and use **E3C1** for event 3.





Setup of SP value

<p>1 Press [display] repeatedly so that the orange SP indicator lights up on the lower display. The operation display now shows the SP.</p> 	<p>2 If [enter] is pressed, the rightmost digit on the lower display flashes and numerical value can be changed.</p> 
<p>3 Press [←], [v] or [Λ] to change to the desired SP value. The flashing of the number indicates that the setting has not yet been finalized.</p> 	<p>4 If [enter] is pressed, the displayed value is set and the display changes from flashing to continuously lit.</p> 

- For step numbers indicated in red like **2**, the following precaution applies:

If the key lock is set, the numerical value does not flash, and the value cannot be changed. To change a numerical value, cancel the key lock first.









AUTO/MANUAL mode selection

<p>1 Press [display] once to get the operation display.</p>  <p>The [mode] key can be used for 1 of 7 different operations. The initial (factory) setting is "AUTO/MANUAL selection".</p>	<p>2 Press and hold [mode] for more than 2s, $\bar{n}Rn$ flashes on the lower display.</p>  <p>If the control method is set to "ON/OFF control" and if the DI assignment is "AUTO/MANUAL," the display does not blink and the setting cannot be changed.</p>
<p>3 When $\bar{n}Rn$ appears, stop pressing [mode]. The MV is shown on the lower display. The rightmost digit of the MV on the lower display flashes and its value can be changed.</p> 	<p>4 Press [<], [v] or [λ] to change to the desired MV value. Even while the number is flashing, the MV is changed at the same time that the number is changed.</p> 

For the flashing MV in step 3, either bumpless transition (the same value as before the change) or preset MANUAL value (the value set in setup $\bar{L}2$) can be selected (in setup $\bar{L}19$, Output operation after AUTO-MANUAL change).







Setup of event value

In this example, the event set value and hysteresis for the event 1 operation type is set to deviation high limit.

<p>1 Press [display] once to get the operation display.</p> 	<p>2 Press and hold [para] for more than 2s to get the parameter setup display. $\bar{n}oDE$ flashes on the upper display.</p> 
<p>3 Press [v] twice or [λ] repeatedly, and $\bar{E}u$ flashes on the upper display.</p> 	<p>4 Press [enter] to get $\bar{E}1$ on the upper display and $\bar{0}$ is displayed on the lower display.</p>  <p>$\bar{0}$ on the lower display indicates that the event main setting is "0".</p>
<p>5 If [enter] is pressed, the rightmost digit on the lower display flashes, and can be changed. Press [<], [v], or [λ], and change to the desired value for event set value. In this case, the flashing of the numerical value implies that it is not yet set.</p> 	<p>6 If [enter] is pressed, the changed numerical value is set and changes from flashing to continuously lit.</p> 
<p>Similarly, use $\bar{E}2$ to set a value for event 2, and $\bar{E}3$ to set a value for event 3.</p>	
<p>7 To continue from this point and set hysteresis as well, press [v] twice or [λ] repeatedly to get $\bar{E}1H5$ on the upper display. The lower display says 5.</p>  <p>5 on the lower display indicates that the event hysteresis is "5".</p>	<p>8 In the same way that event settings were changed, press [enter] to make the number flash, and then press [<], [v] or [λ] to change to the desired setting for hysteresis. After that, press [enter] to finalize the setting.</p> 

Similarly, use $\bar{E}2H5$ to set a value for event 2, and $\bar{E}3H5$ to set a value for event 3.

Setup of PID value

<p>1 Press [display] once to get the operation display.</p> 	<p>2 Press and hold [para] for more than 2s to get the parameter setup display. $\bar{n}oDE$ flashes on the upper display.</p> 
<p>3 Press [v] or [λ] repeatedly until $\bar{P}i$ is flashing on the upper display.</p> 	<p>4 When [enter] is pressed, $\bar{P}-i$ (for proportional band of PID group No. 1) is shown on the upper display, and the preset value is shown on the lower display.</p>  <p>If the control method is "ON/OFF control," nothing is displayed.</p>
<p>5 Press [enter]. The rightmost digit on the lower display flashes and its numerical value can be changed. Press [<], [v] or [λ] to change to the desired proportional band setting. The flashing of the number indicates that the setting change has not yet been finalized.</p> 	<p>6 If [enter] is pressed, the changed numerical value is set and changes from flashing to continuously lit.</p>  <p>The proportional band can be set in a range from 0.1 to 999.9%.</p>

Similarly, use $\bar{I}-i$ to set the integral time (0 to 9999s), and $\bar{D}-i$ to set the derivative time (0 to 9999s).

List of parameter

- Essential parameters for PV measurement and control
- Basic parameters
- Required parameters when using optional functions

List of operation displays

Display	Item	Contents	Initial value	Setting value
Upper display: PV Lower display: SP				
SP	SP(Target value)	SP low limit to SP high limit	0	
LSP # (Display example) LSP	LSP group number (1st digit=the right end digit)	1 to LSP system group (Max. 4)	1	
PV MV	MV (Manipulated Variable)	-10.0 to +110.0% Setting is enabled in MANUAL mode (Numeric value flashed)	-	
HEAT Numeric value	Heat MV (Manipulated Variable)	Setting is disabled.	-	
COOL Numeric value	Cool MV (Manipulated Variable)	-10.0 to +110.0%	-	
PV AT # (Display example) AT	AT progress display (1st digit=the right end digit)	Setting is disabled.	-	
CT1 Numeric value	CT current value 1	Setting is disabled.	-	
CT2 Numeric value	CT current value 2	Setting is disabled.	-	
E1 Numeric value	Internal Event 1 main setting	-1999 to +9999U or 0 to 9999U	0	
E1.5b Numeric value	Internal Event 1 sub setting			
E1. -- (Display example) Numeric value	Internal Event 1 remaining time	Setting is disabled. " r ", is displayed at the right end digit when using the ON delay time, and " L ", the OFF delay time.	-	
E2 Numeric value	Internal Event 2 main setting	Same as Internal Event 1 main setting	0	
E2.5b Numeric value	Internal Event 2 sub setting	Same as Internal Event 1 sub setting	0	
E2. -- (Display example) Numeric value	Internal Event 2 remaining time	Same as Internal Event 1 remaining time	-	
E3 Numeric value	Internal Event 3 main setting	Same as Internal Event 1 main setting	0	
E3.5b Numeric value	Internal Event 3 sub setting	Same as Internal Event 1 sub setting	0	
E3. -- (Display example) Numeric value	Internal Event 3 remaining time	Same as Internal Event 1 remaining time	-	

List of parameter setting displays

Display	Item	Contents	Initial value	Setting value
MANUAL	AUTO/MANUAL	MANUAL mode	AUTO	
RUN/READY	RUN/READY	RUN mode	RUN	
AT stop/start	AT stop/start	AT stop	AT start	
Release all DO latches	Release all DO latches	Latch continue	Latch release	
Communication DI1	Communication DI1	OFF	ON	

Display	Item	Contents	Initial value	Setting value
SP-1 to SP-4	SP of LSP 1 group to 4 group	SP low limit to SP high limit	0	
PID1 to PID4	PID group number (LSP 1 to 4)	1 to 4	1	

Display	Item	Contents	Initial value	Setting value
E1 to E5	Internal Event 1 to 5 main setting	-1999 to +9999 or 0 to 9999	0	
E1.5b to E5.5b	Internal Event 1 to 5 sub setting	(The decimal point position may vary so that it meets the operation type of the internal event)	0	
E1.HY to E5.HY	Internal Event 1 to 5 hysteresis	0 to 9999 (The decimal point position may vary so that it meets the operation type of the internal event)	5	
E1.ON to E5.ON	Internal Event 1 to 5 ON delay time	0.0 to 999.9 or 0 to 9999	0	
E1.OFF to E5.OFF	Internal Event 1 to 5 OFF delay time			

Display	Item	Contents	Initial value	Setting value
P-1 to P-4	Proportional band (PID1 to 4)	0.1 to 999.9%	5.0	
I-1 to I-4	Integral time (PID1 to 4)	0 to 9999s or 0.0 to 999.9s (No integration control action when set at "0")	120	
D-1 to D-4	Derivative time (PID1 to 4)	0 to 9999s or 0.0 to 999.9s (No derivative control action when set at "0")	30	
r-E-1 to r-E-4	Manual reset (PID1 to 4)	-10.0 to +110.0%	50.0	
oL-1 to oL-4	MV low limit (PID1 to 4)	-10.0 to +110.0%	0.0	
oH-1 to oH-4	MV high limit (PID1 to 4)	-10.0 to +110.0%	100.0	
P-1C to P-4C	Proportional band (cool) (PID1 to 4)	0.1 to 999.9%	5.0	
I-1C to I-4C	Integral time (cool) (PID1 to 4)	0 to 9999s or 0.0 to 999.9s (No integration control action when set at "0")	120	
D-1C to D-4C	Derivative time (cool) (PID1 to 4)	0 to 9999s or 0.0 to 999.9s (No derivative control action when set at "0")	30	
oL-1C to oL-4C	Output low limit (cool) (PID1 to 4)	-10.0 to +110.0%	0.0	
oH-1C to oH-4C	Output high limit (cool) (PID1 to 4)	-10.0 to +110.0%	100.0	

Display	Item	Contents	Initial value	Setting value
Control				
Control	Control method	0: ON/OFF control 1: Fixed PID	0 or 1	
Control	MV low limit at AT	-10.0 to +110.0%	0.0	
Control	MV high limit at AT	-10.0 to +110.0%	100.0	
Control	Differential (for ON/OFF control)	0 to 9999U	5	
PV	ON/OFF control action point offset	-1999 to +9999U	0	
PV	PV filter	0.0 to 120.0s	0.0	
PV	PV ratio	0.001 to 9.999	1.000	
PV	PV bias	-1999 to +9999U	0	
Time proportional control	Time proportional cycle unit 1	0 to 3 *1		
Time proportional control	Time proportional cycle 1	5 to 120s or 1 to 120s *2	10 or 2	
Time proportional control	Time proportional cycle unit 2	0 to 3 *1		
Time proportional control	Time proportional cycle 2	5 to 120s or 1 to 120s *2	10 or 2	
Time proportional control	Time proportional cycle mode	0: Controllability aiming type 1: Operation end service life aiming type(Only ON/OFF operation within Time proportional cycle)	0 or 1	
SP	SP up ramp	0.0 to 999.9U(No ramp when set at "0.0U")	0.0	
SP	SP down ramp		0.0	

*1 0: Unit of "1s" 1: Fixed at 0.5s 2: Fixed at 0.2s 3: Fixed at 0.1s
*2 5 to 120s when output includes the relay output U: Unit Maximum unit of Industrial volume in PV range (°C, Pa/L/min, etc.)

[Extended tuning bank]

Display	Item	Contents	Initial value	Setting value
AT	AT type	0: Normal 1: Immediate response 2: Stable *1	1	
JF.bd	Just-FITTER setting band	0.00 to 10.00	0.30	
SP.LB	SP lag constant	0.0 to 999.9	0.0	
AT-P	Proportional band tuning factor at AT	0.00 to 99.99	1.00	
AT-I	Integral time adjust at AT	0.00 to 99.99	1.00	
AT-D	Derivative time adjust	0.00 to 99.99	1.00	
CT.R	Control algorithm	0: PID(Conventional PID) 1: Ra-PID(High-performance PID)	0	
JF.ov	Just-FITTER overshoot suppression factor	0 to 100	0	

*1 Normal = Standard control characteristics, Immediate response = Control characteristics that respond immediately to external disturbance, Stable = Control characteristics having less up/down fluctuation of PV

List of setup setting displays

[Setup bank]

Display	Item	Contents	Initial value	Setting value
ANALOG INPUT				
ANALOG INPUT	PV input range type	For details, refer to the PV Input Range Table	88	
ANALOG INPUT	Temperature unit	0: Celsius (°C) 1: Fahrenheit (°F)	0	
ANALOG INPUT	Cold junction compensation	0: Performed (internal) 1: Not performed (external)	0	
ANALOG INPUT	Decimal point position	0: No decimal point 1 to 3: 1 to 3 digits below decimal point	0	
ANALOG INPUT	PV input range low limit	When the PV input type is DC voltage/DC current, -1999 to +9999U	1000	
ANALOG INPUT	PV input range high limit			
ANALOG INPUT	SP low limit	PV input range low limit to PV input range	0	
ANALOG INPUT	SP high limit	high limit	1000	
ANALOG INPUT	PV square root extraction dropout	0.0 to 100.0% (PV square root extraction is not performed when set at "0.0.")	0.0	
CONTROL ACTION				
CONTROL ACTION	Control action (Direct/Reverse)	0: Heat control (Reverse action) 1: Cool control (Direct action)	0	
CONTROL ACTION	Output operation at PV alarm	0: Control calculation is continued. 1: Output at PV alarm is output.	0	
CONTROL ACTION	Output at PV alarm	-10.0 to +110.0%	0.0	
CONTROL ACTION	Output at READY (Heat)	-10.0 to +110.0%	0.0	
CONTROL ACTION	Output at READY (Cool)	-10.0 to +110.0%	0.0	
CONTROL ACTION	Output operation at changing AUTOMANUAL	0: Bumpless transfer 1: Preset		
CONTROL ACTION	Preset MANUAL value	-10.0 to +110.0%	0.0 or 50.0	
CONTROL ACTION	Initial output type of PID control	0: Auto 1: Not initialized 2: Initialized	0	
CONTROL ACTION	Initial output of PID control	-10.0 to +110.0%	0.0 or 50.0	
CONTROL ACTION	Heat/Cool control	0: Not used 1: Used	0	
CONTROL ACTION	Heat/Cool selection	0: Normal 1: Energy saving	0	
CONTROL ACTION	Heat/Cool control dead zone	-100.0 to +100.0%	0.0	
CONTROL ACTION	Heat/Cool control change point	-10.0 to +110.0%	50.0	
CONTROL ACTION	LSP system group	1 to 4	1	
CONTROL ACTION	SP ramp unit	0: 0.1U/s 1: 0.1U/min 2: 0.1U/h	1	
CONTROL ACTION	CT1 operation type	0: Heater burnout detection 1: Current value measurement	0	
CONTROL ACTION	CT1 output	0 to 1: Control output 1 to 2, 2 to 4: Event output 1 to 3	0	
CONTROL ACTION	CT1 measurement wait time	30 to 300ms	30	
CONTROL ACTION	CT2 operation type	Same as CT1	0	
CONTROL ACTION	CT2 output	Same as CT1	0	
CONTROL ACTION	CT2 measurement wait time	Same as CT1	30	
CONTROL ACTION	Control output 1 range	1: 4 to 20mA 2: 0 to 20mA	1	
CONTROL ACTION	Control output 1 type	0: MV 1: Heat MV 2: Cool MV 3: PV 4: Ratio, bias, and PV before filter 5: SP 6: Deviation 7: CT1 current value 8: CT2 current value 9: Invalid 10: SP+MV 11: PV/MV	0	
CONTROL ACTION	Control output 1 scaling low limit	-1999 to +9999U	0.0	
CONTROL ACTION	Control output 1 scaling high limit		100.0	
CONTROL ACTION	Control output 1 MV scaling	0 to 9999 (Valid when control output 1 type is 10 or 11)	200	
CONTROL ACTION	Control output 2 range	Same as control output 1	1	
CONTROL ACTION	Control output 2 type	Same as control output 1	3	
CONTROL ACTION	Control output 2 scaling low limit	Same as control output 1	0	
CONTROL ACTION	Control output 2 scaling high limit	Same as control output 1	1000	
CONTROL ACTION	Control output 2 MV scaling	Same as control output 1	200	
CONTROL ACTION	Auxiliary output range	Same as control output 1	1	
CONTROL ACTION	Auxiliary type	Same as control output 1	3	
CONTROL ACTION	Auxiliary output scaling low limit	Same as control output 1	0	
CONTROL ACTION	Auxiliary output scaling high limit	Same as control output 1	1000	
CONTROL ACTION	Auxiliary output MV scaling	Same as control output 1	200	
CONTROL ACTION	CPL/MODBUS	0: CPL 1: MODBUS (ASCII format) 2: MODBUS (RTU format)	0	
CONTROL ACTION	Station address	0 to 127 (Communication is disabled when set at "0")	0	
CONTROL ACTION	Transmission speed (bps)	0: 4800 1: 9600 2: 19200 3: 38400	2	
CONTROL ACTION	Data format (Data length)	0: 7 bits 1: 8 bits	1	
CONTROL ACTION	Data format (Parity)	0: Even parity 1: Odd parity 2: No parity	0	
CONTROL ACTION	Data format (Stop bit)	0: 1 bit 1: 2 bits	0	
CONTROL ACTION	Response time-out	1 to 250ms	3	
CONTROL ACTION	Key operation type	0: Standard type 1: Special type	0	
CONTROL ACTION	[mode] key function	0: Invalid 1: AUTO/MANUAL selection 2: RUN/READY selection 3: AT Stop/Start 4: LSP group selection 5: Release all DO latches 6: Invalid 7: Communication DI1 selection 8: Invalid 9: Other invalid setting, 0, +4, +64, +128	0	
CONTROL ACTION	MODE display setup (Sum of the weighting)	Bit 0: AUTO/MANUAL display (Enabled: +1) Bit 1: RUN/READY display (Enabled: +2) Bit 2: Invalid Bit 3: AT Stop/Start display (Enabled: +8) Bit 4: Release all DO latches display (Enabled: +16) Bit 5: Communication DI1 ON/OFF display (Enabled: +32) Other invalid setting, 0, +4, +64, +128	255	
CONTROL ACTION	PV/SP display setup (Sum of the weighting)	Bit 0: PV display (Enabled: +1) Bit 1: SP display (Enabled: +2) Bit 2: LSP group number display (Enabled: +4) Other invalid setting, 0, +8	15	
CONTROL ACTION	MV display setup (Sum of the weighting)	Bit 0: MV display (Enabled: +1) Bit 1: Heat MV/cool MV display (Enabled: +2) Bit 2: Invalid Bit 3: AT progress display (Enabled: +8) Other invalid setting, 0, +4	15	
CONTROL ACTION	EV display setup (Operation display)	0: Not displayed 1: Set value of Internal event 1 is displayed 2: Set values of Internal event 1 to 2 are displayed 3: Set values of Internal event 1 to 3 are displayed	0	
CONTROL ACTION	Timer remain time display setup (Operation display)	0: Not displayed 1: Internal event 1 is displayed 2: Internal event 1 to 2 is displayed 3: Internal event 1 to 3 is displayed	0	
CONTROL ACTION	CT display setup (Operation display)	0: Not displayed 1: CT1 current value is displayed 2: CT1 to 2 current values are displayed	0	
CONTROL ACTION	User level	0: Simple configuration 1: Standard configuration 2: High function configuration	1	
CONTROL ACTION	Communication monitor display	0: Not used 1: Flashing while data is sending through RS-485 communication 2: Flashing while data is receiving through RS-485 communication 3: Logical OR of all DI statuses 4: Flashing in READY mode	0	

- Items marked ● in the tables are displayed in standard and/or high function configuration.
- To change a user level, refer to **Changing the user level** in the lower right part of this page.

Display	Item	Contents	Initial value	Setting value
Key operation + display	● MS display, Condition (top priority)	0: Normally OFF 1: Normally ON 2 to 6: Internal event 1 to 5 7 to 9: Invalid 10 to 13: Undefined 14: MV1 15: MV2 16 to 17: Undefined 18 to 21: DI1 to 4 22 to 25: Undefined 26 to 30: Internal contact 1 to 5 31 to 33: Undefined 34 to 37: Communication DI 1 to 4 38: MANUAL 39: READY 40: Invalid 41: AT 42: During ramp 43: Undefined 44: Alarm 45: PV alarm 46: Undefined 47: [mode] key pressing status 48: Event output 1 terminal status 49: Control output 1 terminal status	39	
	● MS display, Status (top priority)	0: lit 1: Slow flashing 2: Flashing twice 3: Fast flashing 4: Left to right 5: Right to left 6: Reciprocating between left and right 7: Deviation OK 8: Deviation graph 9: MV graph 10: Heat-side MV graph 11: Cool-side MV graph 12: Invalid 13: DI monitor 14: Internal contact monitor 15: Internal event monitor	1	
	● MS display, Condition (secondary priority)	Same as MS display, Condition (top priority)	44	
	● MS display, Status (secondary priority)	Same as MS display, Status (top priority)	6	
	● MS display, Condition (third priority)	Same as MS display, Condition (top priority)	1	
	● MS display, Status (third priority)	Same as MS display, Status (top priority)	9	
	● MS display, Condition (secondary priority)	Same as MS display, Condition (top priority)	5	
	● Special function	0 to 15 (This value becomes "0" when the power is turned ON.)	0	
	● Zener barrier adjustment	The value can be changed with the adjustment. The numeric value cannot be directly input with the manual operation.	0.00	
	● Number of CT1 turns	0: 800 turns 1 to 40: CT turns divided by 100	8	
	● Number of CT1 power wire loops	0: 1 time 1 to 6: Number of times	1	
	● Number of CT2 turns	0: 800 turns 1 to 40: CT turns divided by 100	8	
	● Number of CT2 power wire loops	0: 1 time 1 to 6: Number of times	1	

Event configuration bank

Display	Item	Contents	Initial value	Setting value
● Internal event 1 to 5 Configuration 1 Operation type	Refer to event type (see page 8)	0		
● Internal event 1 to 5 Configuration 2 Operation type	The digits are determined to 1st, 2nd, 3rd, and 4th digit from the right end. 1st digit: Direct/Reverse 0: Direct 1: Reverse 2nd digit: Standby 0: None 1: Standby 2: Standby + Standby at SP change 3rd digit: EVENT state at READY 0: Continue 1: Forced OFF 4th digit: Undefined 0	0		
● Internal event 1 to 5 Configuration 3	The digits are determined to 1st, 2nd, 3rd, and 4th digit from the right end. 1st digit: Controller alarm OR 0: None 1: Alarm direct + OR operation 2: Alarm direct + AND operation 3: Alarm reverse + OR operation 4: Alarm reverse + AND operation 2nd digit: Special OFF setup 0: As usual 1: When the event set value (main setting) is 0, the event is "OFF". 3rd digit: Delay unit 0: 0.1s 1: 1s 2: 1min 4th digit: Undefined 0	0		

DI assignment bank

Display	Item	Contents	Initial value	Setting value
● Internal contact 1 to 5 Operation type	0: No function 1: LSP group selection (0/+1) 2: LSP group selection (0/+2) 3: LSP group selection (0/+4) 4: PID group selection (0/+1) 5: PID group selection (0/+2) 6: PID group selection (0/+4) 7: RUN/READY selection 8: AUTO/MANUAL selection 9: Invalid 10: AT Stop/Start 11: Invalid 12: Control action direct/reverse 13: SP Ramp enabled/disabled 14: PV Hold 15: PV Maximum value hold 16: PV Minimum value hold 17: Timer Stop/Start 18: Release all DO latches (Continue/Release) 19: Invalid 20: Invalid	0		
● Internal contact 1 to 5 Input bit function	0: Not used (Default input) 1: Function 1 ((A and B) or (C and D)) 2: Function 2 ((A or B) and (C or D)) 3: Function 3 (A or B or C or D) 4: Function 4 (A and B and C and D)	0		
● Internal contact 1 to 5 Input assign A	0: Normally opened 1: Normally closed 2 to 5: DI1 to 4 6 to 9: Undefined 10 to 14: Internal Event 1 to 5 15 to 17: Undefined	2: Contact 1 3: Contact 2 4: Contact 3 5: Contact 4		
● Internal contact 1 to 5 Input assign B	18 to 21: Communication DI1 to 4 22: MANUAL 23: READY 24: Invalid	0		
● Internal contact 1 to 5 Input assign C	25: AT tuning 26: During SP ramp 27: Undefined 28: Alarm occurs 29: PV alarm occurs	0		
● Internal contact 1 to 5 Input assign D	30: Undefined 31: mode key pressing status 32: Event output 1 status 33: Control output 1 status	0		
● Internal contact 1 to 5 Polarity A to D	The digits are determined to 1st, 2nd, 3rd and 4th digit from the right end. 0: Direct 1: Reverse	0		
● Internal contact 1 to 5 Polarity	0: Direct 1: Reverse	0		
● Internal contact 1 to 5 Event channel def.	0: Every Internal Event 1 to 8: Internal Event No.	0		

Precaution for setup

The type of auto tuning can be changed by changing the value of AT (AT type) in the extended tuning bank. Set it to match the control characteristics.

DO assignment bank

Display	Item	Contents	Initial value	Setting value
● Operation type (Control output 1 to 2, Event output 1 to 3)	0: Default output 1 to 2: MV1 to 2 3 to 6: Function 1 to 4	0		
● Output assign A (Control output 1 to 2, Event output 1 to 3)	0: Normally opened 1: Normally closed 2 to 6: Internal Event 1 to 5 7 to 9: Invalid 10 to 13: Undefined 14 to 15: MV1 to 2 16 to 17: Undefined 18 to 21: DI1 to 4 22 to 25: Undefined	14: Output 1 15: Output 2 2: Event 1 3: Event 2 4: Event 3 0		
● Output assign B (Control output 1 to 2, Event output 1 to 3)	26 to 30: Internal Contact 1 to 5 31 to 33: Undefined 34 to 37: DI1 to 4 38: MANUAL 39: READY 40: Invalid	0		
● Output assign C (Control output 1 to 2, Event output 1 to 3)	41: AT tuning 42: During SP ramp 43: Undefined 44: Alarm occurs 45: PV alarm occurs 46: Undefined 47: Mode key pressing status	0		
● Output assign D (Control output 1 to 2, Event output 1 to 3)	48: Event output 1 status 49: Control output 1 status	0		
● Control output 1 to 2, Event output 1 to 3 Polarity A to D	The digits are determined to 1st, 2nd, 3rd, and 4th digit from the right end. 0: Direct 1: Reverse	0		
● Polarity (Control output 1 to 2, Event output 1 to 3)	0: Direct 1: Reverse	0		
● Latch (Control output 1 to 2, Event output 1 to 3)	0: None 1: Latch (Latch at ON) 2: Latch (Latch at OFF except for initialization at power ON)	0		

User function bank

Display	Item	Contents	Initial value	Setting value
● User function 1 to 8	–	–	–	–

Lock bank

Display	Item	Contents	Initial value	Setting value
● Key lock	0: All settings are possible 1: Mode, event operation display, SP, UF, lock, manual MV, [mode] key can be set 2: Operation display, SP, UF, lock, manual MV, [mode] key can be set 3: UF, lock, manual MV, [mode] key can be set	0		
● Communication lock	0: read/write enabled 1: read/write disabled	0		
● Loader lock	0: read/write enabled 1: read/write disabled	0		
● Password display	0 to 15/5: Password 1A to 2B display)	0		
● Password 1A	0000 to FFFF (Hexadecimal value)	0000		
● Password 2A	0000 to FFFF (Hexadecimal value)	0000		
● Password 1B	0000 to FFFF (Hexadecimal value)	0000		
● Password 2B	0000 to FFFF (Hexadecimal value)	0000		

Instrument information bank

Display	Item	Contents	Initial value	Setting value
● ROM ID	1: Fixed	Disabled		
● ROM Version 1	XX.XX (2 digits after decimal point)	Disabled		
● ROM Version 2	XX.XX (2 digits after decimal point)	Disabled		
● Loader information		Disabled		
● EST information		Disabled		
● Manufacturing date code (year)	Subtract 2000 from the year. Example: "3" means the year 2003.	Disabled		
● Manufacturing date code (month, day)	Month + day divided by 100. Example: "12.01" means the 1st day of December.	Disabled		
● Serial No.		Disabled		

Changing the user level

This controller's user level can be set to 1 of 3 types in setup C79.

The number of possible displays and settings decreases according to the user level: high function > standard > simple. All items are displayed when high function is selected.

1

If necessary, press [mode] once to change to the operation display. Next, press and hold [para] for more than 2 seconds to get the parameter setup display. **node** flashes on the upper display.

2

Press [v] or [A] repeatedly as needed to get **SLUP** flashing on the upper display.

3

Press [enter]. **C 79** is shown on the upper display. Press [←], [v] or [A] to change to **C 79** (user level).

4

When [enter] is pressed, the lower display flashes. Press [v] or [A] to change to the desired setting, and press [enter] to finalize your selection.

0: Simple configuration
1: Standard configuration (initial value)
2: High function configuration

PV input range table

[Thermocouple]

C01 Set value	Sensor type	Range
1	K	-200 to +1200°C
2	K	0 to 1200°C
3	K	0.0 to 800.0°C
4	K	0.0 to 600.0°C
5	K	0.0 to 400.0°C
6	K	-200.0 to +400.0°C
7	K	-200.0 to +200.0°C
8	J	0 to 1200°C
9	J	0.0 to 800.0°C
10	J	0.0 to 600.0°C
11	J	-200.0 to +400.0°C
12	E	0.0 to 800.0°C
13	E	0.0 to 600.0°C
14	T	-200.0 to +400.0°C
15	R	0 to 1600°C
16	S	0 to 1600°C
17	B	0 to 1800°C
18	N	0 to 1300°C
19	PL II	0 to 1300°C
20	WRe5-26	0 to 1400°C
21	WRe5-26	0 to 2300°C
22	Ni-NiMo	0 to 1300°C
23	PR40-20	0 to 1900°C
24	DIN U	-200.0 to +400.0°C
25	DIN L	-100.0 to +800.0°C
26	Gold iron chromel	0.0K to 360.0K

[RTD]

C01 Set value	Sensor type	Range
41	Pt100	-200.0 to +500.0°C
42	JPt100	-200.0 to +500.0°C
43	Pt100	-200.0 to +200.0°C
44	JPt100	-200.0 to +200.0°C
45	Pt100	-100.0 to +300.0°C
46	JPt100	-100.0 to +300.0°C
47	Pt100	-100.0 to +200.0°C
48	JPt100	-100.0 to +200.0°C
49	Pt100	-100.0 to +150.0°C
50	JPt100	-100.0 to +150.0°C
51	Pt100	-50.0 to +200.0°C
52	JPt100	-50.0 to +200.0°C
53	Pt100	-50.0 to +100.0°C
54	JPt100	-50.0 to +100.0°C
55	Pt100	-60.0 to +40.0°C
56	JPt100	-60.0 to +40.0°C
57	Pt100	-40.0 to +60.0°C
58	JPt100	-40.0 to +60.0°C
59	Pt100	-10.00 to +60.00°C
60	JPt100	-10.00 to +60.00°C
61	Pt100	0.0 to 100.0°C
62	JPt100	0.0 to 100.0°C
63	Pt100	0.0 to 200.0°C
64	JPt100	0.0 to 200.0°C
65	Pt100	0.0 to 300.0°C
66	JPt100	0.0 to 300.0°C
67	Pt100	0.0 to 500.0°C
68	JPt100	0.0 to 500.0°C

[DC voltage/DC current]

C01 Set value	Sensor type	Range
81	0 to 10mV	Scaling range is -1999 to +9999.
82	-10 to +10mV	
83	0 to 100mV	-
84	0 to 1V	
86	1 to 5V	-
87	0 to 5V	
88	0 to 10V	-
89	0 to 20mA	
90	4 to 20mA	

Initial value

*1: If the ROM version 1 of the instrument information bank (1.0.0) is prior to 2.04, a setting of "3" for the PV input range type (2.0) will result in display of the K thermocouple 0 to 800°C range with no decimal point.

*2: The indicated low limit for a B thermocouple is 20°C. However, if ROM version 1 of the instrument information bank (1.0.0) is prior to 2.04, the value is -180°C.

Event type

Operation type	Set value	Direct action	Reverse action
No event	0	Always OFF	Always OFF
PV high limit	1		
PV low limit	2		
PV high/low limit	3		
Deviation high limit	4		
Deviation low limit	5		
Deviation high/low limit	6		
Deviation high limit (Final SP reference)	7		
Deviation low limit (Final SP reference)	8		
Deviation high/low limit (Final SP reference)	9		
Heater 1 burnout/Over-current	16		
Heater 1 short-circuit	17		
Heater 2 burnout/Over-current	18		
Heater 2 short-circuit	19		
Alarm (status)	23	ON if alarm occurs (alarm code AL01 to 99). OFF in other cases.	OFF if alarm occurs (alarm code AL01 to 99). ON in other cases.

Initial value

*: If the main setting is greater than the sub-setting, operations are performed with the main setting and sub-setting automatically swapped.

Event types other than the above:

Operation type	Set value	Operation type	Set value	Operation type	Set value
SP high limit	10	Loop diagnosis 1	20	During AT (status)	27
SP low limit	11	Loop diagnosis 2	21	During SP ramp	28
SP high/low limit	12	Loop diagnosis 3	22	Control action (status)	29
MV high limit	13	READY (status)	24	ST setting standby (status)	30
MV low limit	14	MANUAL (status)	25	Estimated position control (status)	31
MV high/low limit	15	RSP (status)	26	Timer (status)	32

azbil

Specifications are subject to change without notice.

Yamatake Corporation
Advanced Automation Company

1-12-2 Kawana, Fujisawa
Kanagawa 251-8522 Japan

URL: <http://www.azbil.com>

Printed on recycled paper. (07)

Printed in Japan.

1st Edition: Issued in Nov. 2007 (W)

List of alarm code

Alarm code	Failure name	Cause	Corrective action
AL01	PV input failure (Over-range)	Sensor burnout, incorrect wiring, incorrect PV input type setting	Check the wiring. Set the PV input type again.
AL02	PV input failure (Under-range)	Sensor burnout, incorrect wiring, incorrect PV input type setting	
AL03	CJ failure	Terminal temperature is faulty (thermocouple).	Check the ambient temperature.
AL11	PV input failure (RTD)	Sensor burnout, incorrect wiring	Check the wiring.
	CT input failure (Over-range) (CT input 1 or 2, or both)	A current exceeding the upper limit of the display range was measured. The number of CT turns or the number of CT power wire loops is incorrectly set, or wiring is incorrect.	<ul style="list-style-type: none"> Use a CT with the correct number of turns for the display range. Reset the number of CT turns. Reset the number of CT power wire loops. Check the wiring.
AL17	A/D conversion failure	A/D converter is faulty.	Replace the unit.
AL45	Parameter failure	Power is shut-down while the data is being set, or data is corrupted by noise.	<ul style="list-style-type: none"> Restart the unit. Set the data again (set data for AL45/47 and adjustment data for AL45/48). Replace the unit.
AL46	Adjustment data failure	Power is shut-down while the data is being set, or data is corrupted by noise.	Replace the unit.
AL47	Parameter failure (RAM area)	Data is corrupted by noise.	<ul style="list-style-type: none"> Reset the unit. Replace the unit.
AL48	Adjustment data failure (RAM area)	Data is corrupted by noise.	
AL49	ROM failure	ROM (memory) is faulty.	

Handling precautions

- If ROM version 1 of the instrument information bank (1.0.0) is prior to 2.04, CT input failure (AL11) is not displayed.