

SDC45V/46V Digital Indicating Controller User's Manual for Computational Functions



Thank you for purchasing the SDC45V/46V Digital Indicating Controller.

This manual contains information for ensuring the correct use of the computational functions of the SDC45V/46V. Please also read the Installation and Configuration manual (CP-SP-1218E) and the Displays and Settings manual (CP-SP-1265E) before using the SDC45V/46V.

Keep these manuals nearby for handy reference.

Yamatake Corporation

RESTRICTIONS ON USE

This product has been designed, developed and manufactured for general-purpose application in machinery and equipment.

Accordingly, when used in applications outlined below, special care should be taken to implement a fail-safe and/or redundant design concept as well as a periodic maintenance program.

- Safety devices for plant worker protection
- Start/stop control devices for transportation and material handling machines
- Aeronautical/aerospace machines
- Control devices for nuclear reactors

Never use this product in applications where human safety may be put at risk.

NOTICE

Be sure that the user receives this manual before the product is used.

Copying or duplicating this user's manual in part or in whole is forbidden. The information and specifications in this manual are subject to change without notice.

Considerable effort has been made to ensure that this manual is free from inaccuracies and omissions. If you should find an error or omission, please contact Yamatake Corporation.

In no event is Yamatake Corporation liable to anyone for any indirect, special or consequential damages as a result of using this product.

©2008 Yamatake Corporation ALL RIGHTS RESERVED

Conventions Used in This Manual

The following conventions are used in this manual:

! Handling Precautions:

Handling Precautions indicate items that the user should pay attention to when handling the SDC45V/46V.

📖 Note:

Notes indicate information that might benefit the user.



This indicates the item or page that the user is requested to refer to.

(1), (2), (3):

Numbers within parentheses indicate steps in a sequence or parts of an explanation.

[para]key, [<] key::

Indicates keys on the panel.

"man" LED:

Indicates various indicators on this unit.

>>:

Indicates the result of an operation, details displayed on the personal computer or other devices, or the state of the device after operation.

● **Numeric value and character display on LED**

● **7-segment LED**

Numeric values: The 7-segment LED expresses numeric values as follows:

0		1		2		3		4		-1	
5		6		7		8		9			

Alphabetical characters: The 7-segment LED expresses alphabetical characters shown below. There are some alphabetical characters, which are not displayed on the LED.

A		B		C		D		E	
a		b		c		d		e	
F		G		H		I		J	
f		g		h		i		j	
K		L		M		N		O	
k		l		m		n		o	
P		Q		R		S		T	
p		q		r		s		t	
U		V		Y		Z		-	
u		v		y		z			

! Handling Precautions

- As shown above, numeric value "2" and alphabetic character "Z" are shown in the same manner. Accordingly, numeric value "5" and alphabetic character "S", as well as numeric value "9" and alphabetic character "Q" are also shown in the same manner.

● **11-segment LED**

Numeric values: The 11-segment LED expresses numeric values as follows:

0		1		2		3		4	
5		6		7		8		9	

Alphabetical characters: The 11-segment LED expresses alphabetical characters shown below. There are some alphabetical characters, which are not displayed on the LED.

A		B		C		D		E		F	
a		b		c		d		e		f	
G		H		I		J		K		L	
g		h		i		j		k		l	
M		N		O		P		Q		R	
m		n		o		p		q		r	
S		T		U		V		W		X	
s		t		u		v		w		x	
Y		Z									
y		z									

! Handling Precautions

- As shown above, numeric value "5" and alphabetic character "S" are shown in the same manner.

The Role of This Manual

A total of 5 different manuals are available for the SDC45V/46V. Read them as necessary for your specific requirements. If a manual you require is not available, contact Yamatake Corporation or its dealer.

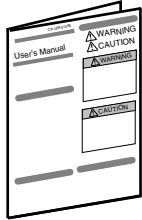

SDC45/46 Digital Indicating Controller Installation Instructions Manual No. CP-UM-5445E

This manual is supplied with the SDC45/46. Personnel in charge of design and/or manufacture of a system using the SDC45/46 must thoroughly read this manual. This manual describes the safety precautions, installation, wiring, primary specifications, and transitions of key operations and displays. For further information about operation, refer to another manual, Installation and Configuration.

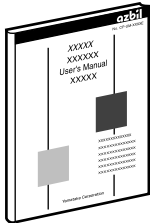

SDC45/46 Digital Indicating Controller User's Manual for Displays and Settings Manual No. CP-SP-1265E

The manual is a reference document necessary to set or change data. The manual lists up the displays, setup items, setting ranges, and initial values.

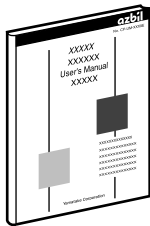

SDC45A/46A Digital Indicating Controller User's Manual for Installation and Configuration Manual No. CP-SP-1218E

Personnel in charge of design, manufacture, operation, and/or maintenance of a system using SDC45/46 must thoroughly read this manual. This manual also describes the installation, wiring, connections for communication, all functions and settings of the SDC45/46, operating procedures, troubleshooting, and detailed specifications.

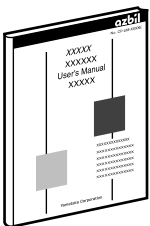

SDC45V/46V Digital Indicating Controller User's Manual for Computational Functions Manual No. CP-SP-1275E

This manual.

It describes the computation functions of the SDC45V/46V. Please read it together with the Installation and Configuration manual (CP-SP-1218E) and the Displays and Settings manual (CP-SP-1265E).

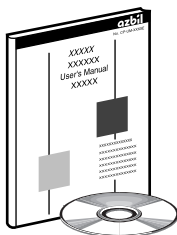

SLP-C45 Smart Loader Package for the SDC45/46 Digital Indicating Controller Manual No. CP-UM-5458E

This manual is supplied with the SLP-C45 Smart Loader Package. The manual describes the software used to make various settings for the SDC45/46 using a personal computer. Personnel in charge of design or setting of a system using SDC45/46 must thoroughly read this manual. The manual describes installation of the software into a personal computer, operation of the personal computer, various functions, and setup procedures.

Organization of This User's Manual

This manual is organized as follows:

Flowchart of key operations and displays

This section summarizes the flowchart of key operations and displays of the SDC45/46 in the diagram so as to describe them.

Chapter 1. MODEL SELECTION TABLE

This chapter describes the model selection of the SDC45V/46V.

Chapter 2. WIRING

This chapter describes the wiring procedures of the SDC45V/46V.

Chapter 3. FUNCTION SETUP

Tells how to configure the settings and assignments required to operate the computational functions of the SDC45V/46V.

Chapter 4. SAMPLE SETTINGS

This chapter gives examples of actual settings used for different applications.

Chapter 5. ALARM CODE LIST

Contains a table of the alarm codes of the SDC45V/46V.

Chapter 6. LIST OF SETTING DATA AND COMMUNICATION DATA

Contains a table of the settings and communication data of the SDC45V/46V.

Contents

Conventions Used in This Manual	
The Role of This Manual	
Organization of This User's Manual	
Flowchart of key operations and displays	

Chapter 1. MODEL SELECTION TABLE

■ SDC45V	1
■ SDC46V	2

Chapter 2. WIRING

2-1 PV Input Connections	3
■ PV1 connections	3
■ PV2 connections (2 inputs model)	3
■ Connection of PV21 and PV22 (3 inputs model)	3

Chapter 3. FUNCTION SETUP

3-1 Loop Type	4
■ Overview	4
■ Loop type	4
■ SDC45V/46V data assignment	5
3-2 Input Type	6
■ Thermocouple	6
■ Resistance temperature detector (RTD)	6
■ DC voltage/DC current	6
3-3 Computation Functions	7
■ Overview	7
■ Timing of execution of computational functions	7
■ Computation patterns	8
■ Components of computation patterns (F1 to F10)	8
■ Mathematical/logical operations	9
■ Important supplemental information	19
3-4 Power Failure Detection	21
■ Overview	21
■ Bank and settings	21
■ Measurement of power failure time	21
■ How to check for power failure	21
■ How to reset the power failure detection	22
3-5 Hot Start	23
■ How to use the function	23
■ Conditions for hot start	23
■ Operating specifications	23

■	Backed up data	23
■	How to check the status of hot start and reset.....	23
3-6	Temperature-Pressure Correction.....	24
■	2 inputs model.....	24
■	3 inputs model.....	24
■	Temperature correction.....	25
■	Pressure correction.....	25
■	Flow rate scaling	25
■	Operating specifications if settings are abnormal	26
Chapter 4.	SAMPLE SETTINGS.....	27
Chapter 5.	ALARM CODE LIST	34
Chapter 6.	LIST OF SETTING DATA AND COMMUNICATION DATA	
6-1	Control Bank (Ctrl)	35
6-2	Temperature-Pressure Correction Bank (Temp, P)	37
6-3	Input Computation Bank (In, Fnc)	38
6-4	Output Computation Bank (Out, Fnc).....	40
6-5	List of Communication Data.....	42
6-6	Standard Bit Codes and Standard Numerical Codes	49
■	Standard bit codes.....	49
■	Standard numerical codes.....	50

Flowchart of key operations and displays

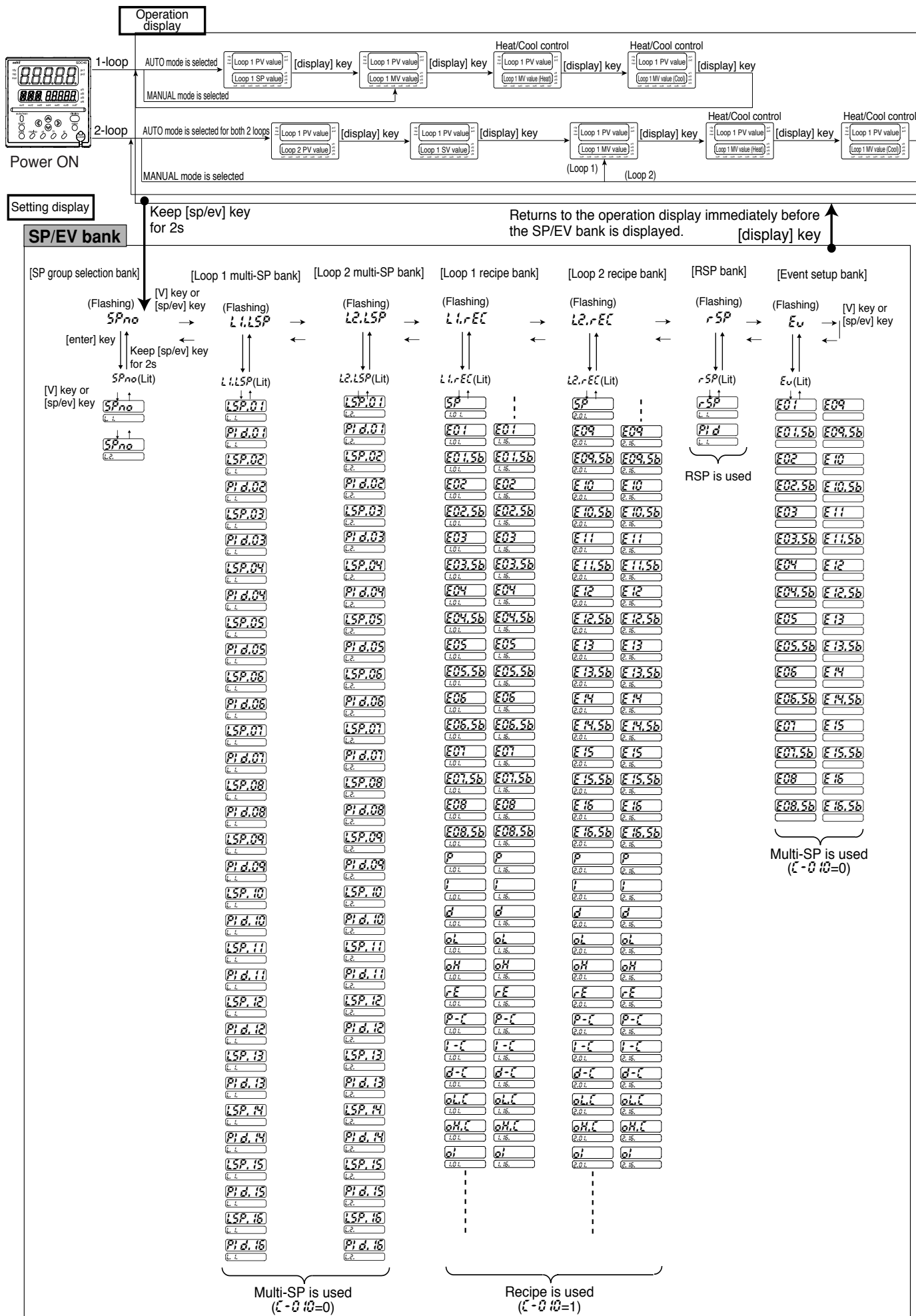

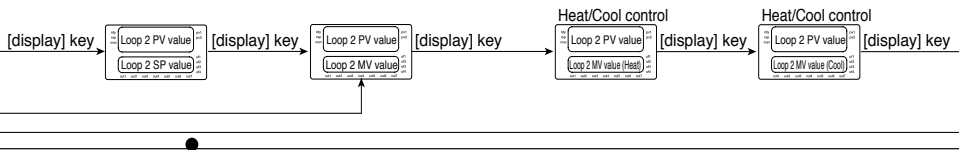

Keep [para] key pressed for 2s → Returns to the operation display immediately before the PARA bank is displayed. [display] key

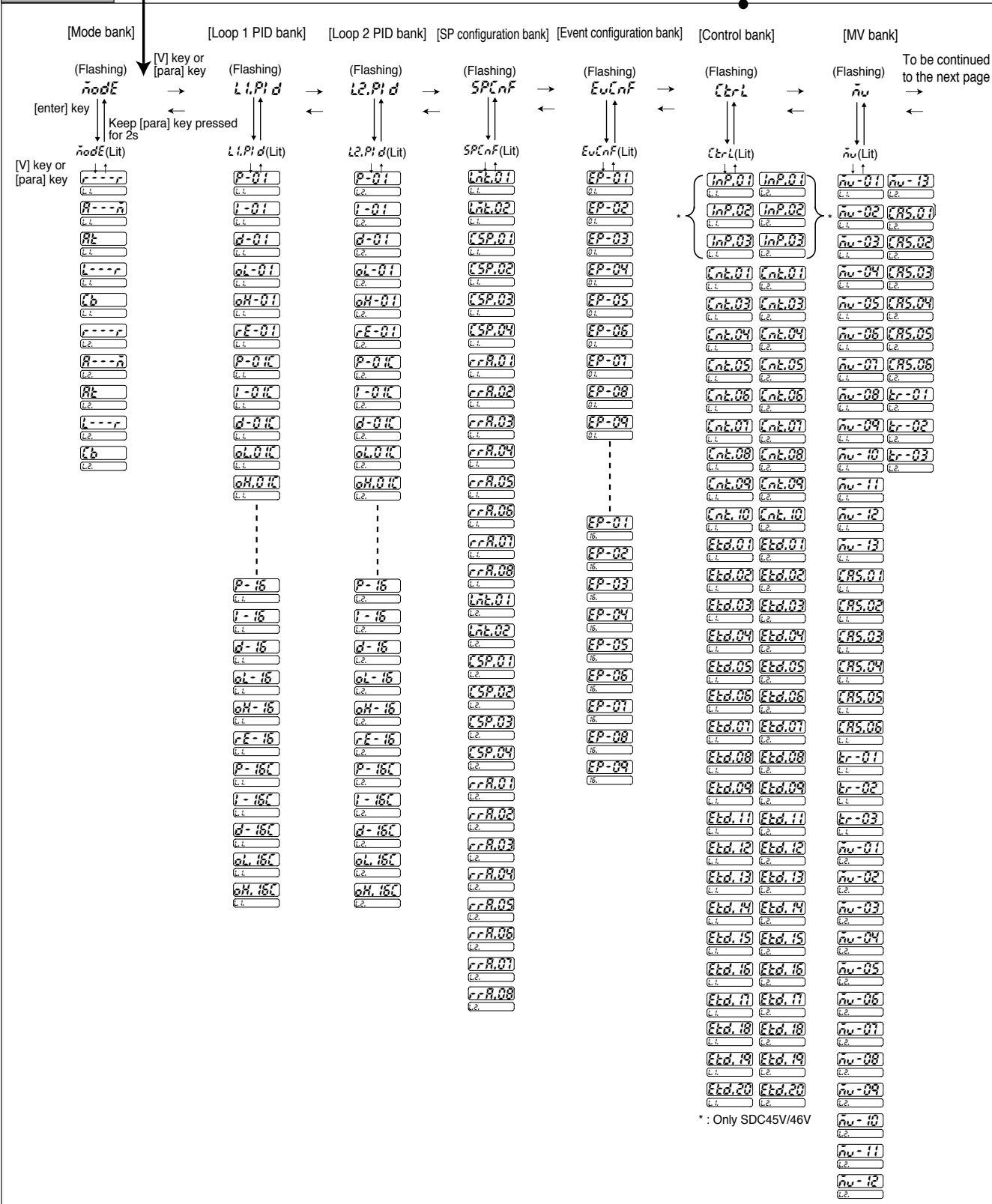

Return to the operation display immediately before the PARA bank is displayed

[display] key ↑

PARA bank

Continued from the previous page

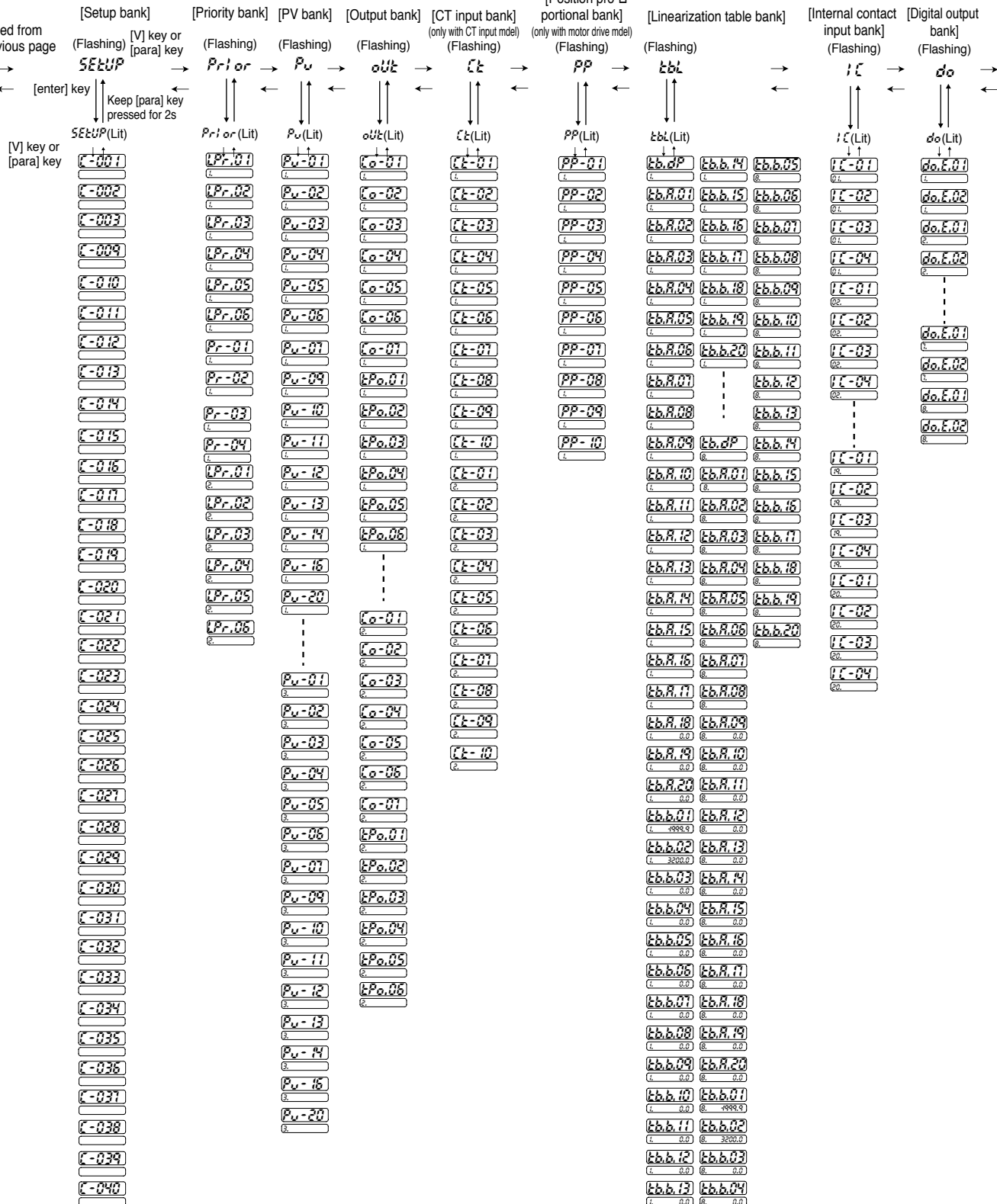

■ Movement within bank

- Forward movement
[sp/ev] key or [V] key (SP/EV bank)
[para] key or [V] key (PARA bank)
- Backward movement
[Λ] key

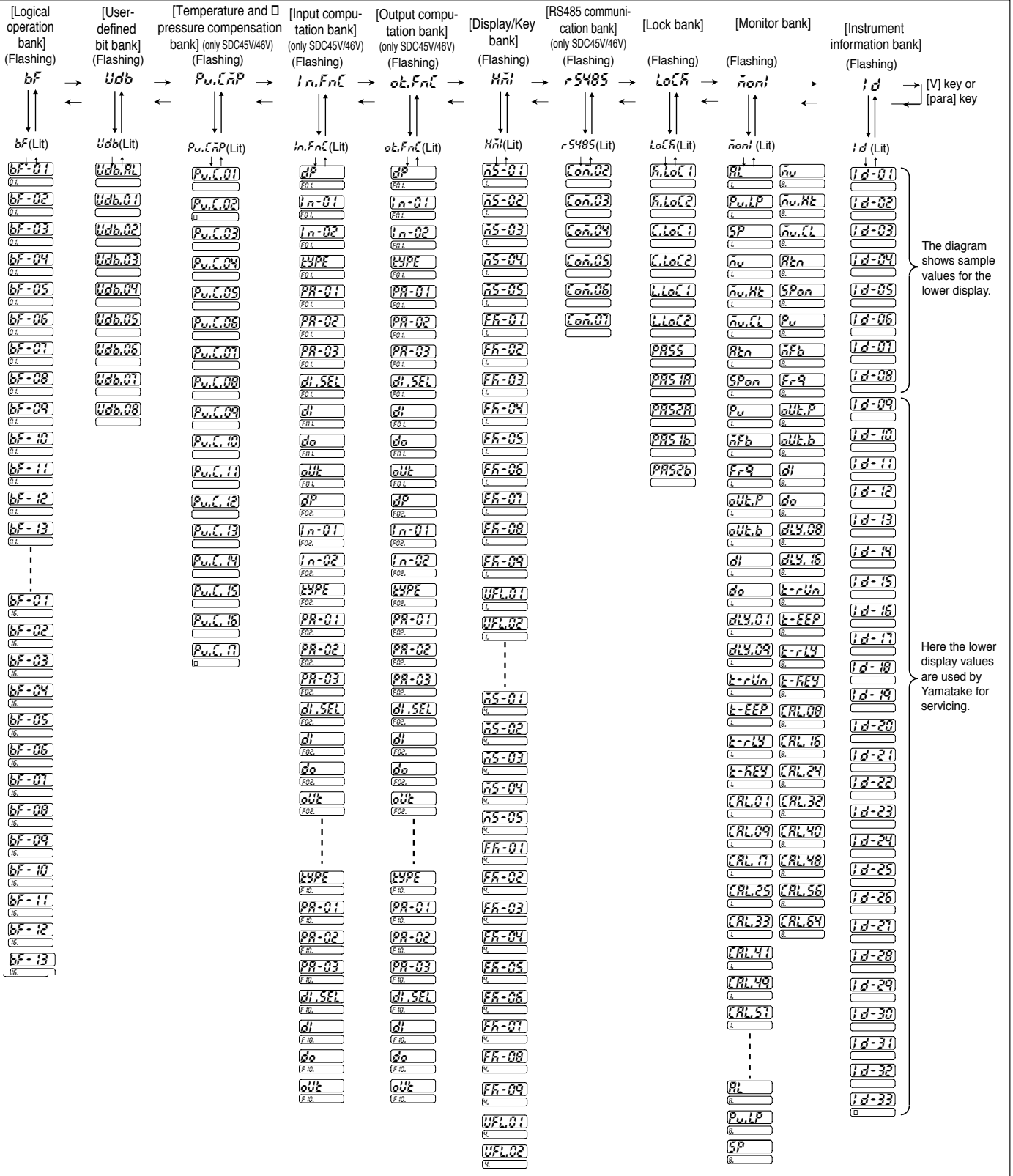

Chapter 1. MODEL SELECTION TABLE

■ SDC45V

Basic model No.	Input model	Power supply	Output 1, 2	Output 3, 4	Output 5	Output 6, 7	Option	Addition 1	Addition 2	Specifications	
C45V										Computation function model	
	2									2 inputs (full multiple 2)	
	3									3 inputs (full multiple 1, linear 2) *2	
		A									100 to 240 Vac
		D									24 Vdc
				1							1 form 1a1b relay
				2							2 form 1a relays
					C0						Current output (output 3)
					D0						Continuous voltage output (output 3)
					V0						Voltage pulse output (output 3)
					RR						2 form 1a relays
					CC						2 current outputs
					VV						2 voltage pulse outputs
					CV						Current (output 3) + voltage pulse (output 4)
					SS						Motor drive triac + MFB input
						0					None
						R					Form 1a relay
						C					Current output
						D					Continuous voltage output
						P					Transmitter power supply
							0				None
							0				2 digital inputs (DI-F1/2) *1
							1				10 digital inputs *2
							2				2 digital inputs + 8 digital outputs *1
							3				2 digital inputs + 8 digital outputs + RS-485 communication *1
							4				2 CT inputs *3
							5				2 CT inputs + 8 digital inputs *3
							6				2 CT inputs + 8 digital outputs *3
							7				2 CT inputs + 8 digital outputs + RS-485 communication *3
								0			None
							T			Tropicalization treatment	
							K			Anti-sulfide treatment	
							D			Inspection certificate	
							B			Tropicalization treatment + inspection certificate	
							L			Anti-sulfide treatment + inspection certificate	
							Y			Complying with the traceability certification	
							Z			Tropicalization treatment + Complying with the traceability certification	
							X			Anti-sulfide treatment + Complying with the traceability certification	
								0		None	
								1		LEDs: all orange	

*1: There are no digital inputs if "SS" is selected for Outputs 3, 4.

*2: There are 8 digital inputs if "SS" is selected for Outputs 3, 4.

*3: Cannot be selected if "SS" is selected for Outputs 3, 4.

■ SDC46V

Basic model No.	Input model	Power supply	Output 1, 2	Output 3, 4	Output 5	Output 6, 7	Option	Addition 1	Addition 2	Specifications	
C46V										Computation function model	
	2									2 inputs (full multiple 2)	
	3									3 inputs (full multiple 1, linear 2)	
		A									100 to 240 Vac
		D									24 Vdc
				1							1 form 1a1b relay
				2							2 form 1a relays
					C0						Current output (output 3)
					D0						Continuous voltage output (output 3)
					V0						Voltage pulse output (output 3)
					RR						2 form 1a relays
					CC						2 current outputs
					VV						2 voltage pulse outputs
					CV						Current (output 3) + voltage pulse (output 4)
					SS						Motor drive triac + MFB input
					R1						Motor drive relay + MFB input
						0					None *5
						R					Form 1a relay *5
						C					Current output *5
						D					Continuous voltage output *5
						P					Transmitter power supply *5
							0				None
							1				Current output (output 6)
							2				Transmitter power supply (output 7)
							3				2 current outputs *1
							4				Current (output 6) + transmitter power supply (output 7)
								0			2 digital inputs (DI-F1/2) *2
								1			14 digital inputs *3
								2			14 digital inputs + 8 digital outputs *3
								3			14 digital inputs + 8 digital outputs + RS-485 communication *3
								4			2 CT inputs *4
								5			2 CT inputs + 12 digital inputs *4
								6			2 CT inputs + 12 digital inputs + 8 digital outputs *4
							7			2 CT inputs + 12 digital inputs + 8 digital outputs + RS-485 communication *4	
								0		None	
								T		Tropicalization treatment	
								K		Anti-sulfide treatment	
								D		Inspection certificate	
								B		Tropicalization treatment + inspection certificate	
								L		Anti-sulfide treatment + inspection certificate	
								Y		Complying with the traceability certification	
								Z		Tropicalization treatment + Complying with the traceability certification	
								X		Anti-sulfide treatment + Complying with the traceability certification	
									0	None	
									1	LEDs: all orange	

- *1: Not available if "CC" is selected for Outputs 3, 4 and "C" is selected for Output 5.
- *2: Selection must be "0" if "R1" is selected for Outputs 3, 4.
- *3: There are no digital inputs if "SS" or "R1" is selected for Outputs 3, 4.
- *4: There are 12 digital inputs if "SS" or "R1" is selected for Outputs 3, 4.
- *5: Not available if "SS" or "R1" is selected for Outputs 3, 4.

Chapter 2. WIRING

2 - 1 PV Input Connections

! Handling Precautions

- Do not apply a voltage exceeding the allowable input voltage described in the specifications to each input. Doing so might cause the unit to malfunction.
- Make the connections properly while carefully checking the input polarities.
- Always use shielded wires for input wiring.
- When using a thermocouple for the input, take appropriate measures so that the terminal is not exposed to the wind. Failure to do so might cause an error to occur.

■ PV1 connections

• Thermocouple sensor

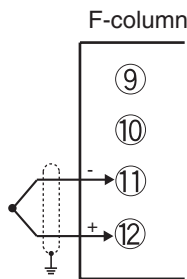

• RTD sensor

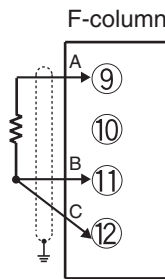

• Linear voltage/linear current sensor

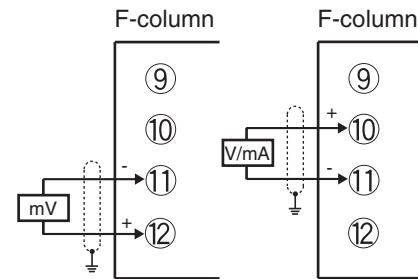

- When the range type is 43 to 46 (0 to 10 mV, -10 to +10 mV, 0 to 100 mV, -100 to +100 mV), terminal Nos. (11) and (12) are used.
- When the range type is 47 to 51 (0 to 1 V, -1 to +1 V, 1 to 5 V, 0 to 5 V, 0 to 10 V), terminal Nos. (10) and (11) are used.

■ PV2 connections (2 inputs model)

• Thermocouple sensor

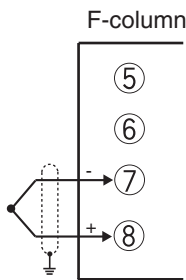

• RTD sensor

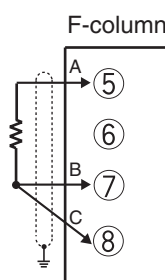

• Linear voltage/linear current sensor

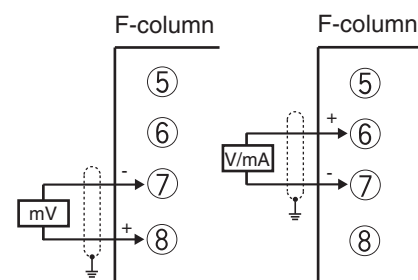

- When the range type is 43 to 46 (0 to 10 mV, -10 to +10 mV, 0 to 100 mV, -100 to +100 mV), terminal Nos. (7) and (8) are used.
- When the range type is 41, 42, and 47 to 51 (0 to 1 V, -1 to +1 V, 1 to 5 V, 0 to 5 V, 0 to 10 V), terminal Nos. (6) and (7) are used.

■ Connection of PV21 and PV22 (3 inputs model)

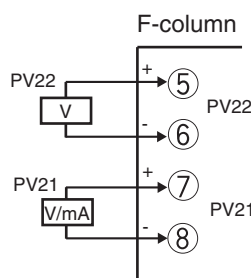

* PV21 and PV22 are not isolated.

Chapter 3. FUNCTION SETUP

3 - 1 Loop Type

Overview

One set of PID control operations is called a loop. Major functions included in a loop are:

- PV
- SP
- MV
- Mode

Loop type

The loop type (control method) can be selected as desired by changing the settings. 2-input models can be set from 0 to 4. 3-input models can be set from 0 to 7. PV, RSP and MV signals from the host computer use the data assigned by the settings in the loop control bank.

Bank	Item display	Item name	Settings
SETUP	Σ-001	Loop type	0: 1-loop, 1: 2-loop (independent), 2: 1-loop (with RSP), 3: 1-loop (computer backup), 4: 1-loop (internal cascade), 5: 2-loop with RSP in one loop, 6: 1 loop (computer backup with RSP), 7: 1-loop (internal cascade with RSP)

0:1-loop 1:2-loop (independent) 2:1-loop (with RSP) 3:1-loop (computer backup) 4:1-loop (internal cascade)

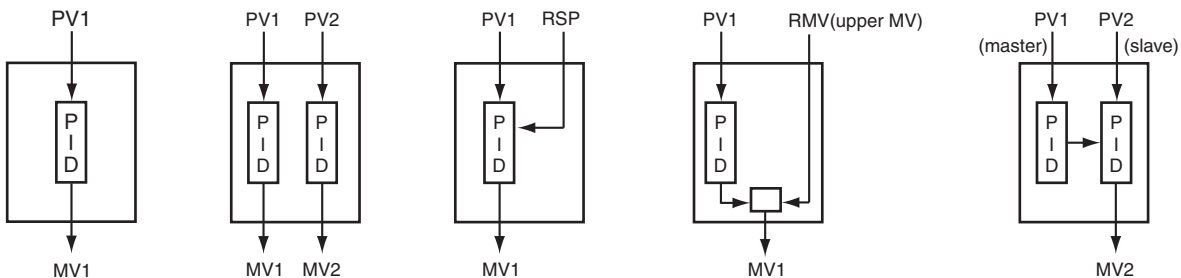

5:2-loop with RSP in one loop 6:1-loop (computer backup with RSP) 7:1-loop (internal cascade with RSP)

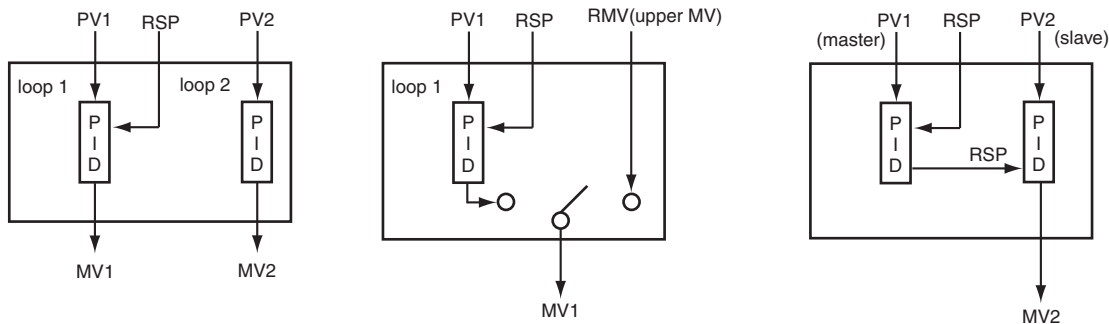

■ SDC45V/46V data assignment

By changing the settings on the SDC45V/56V, the PV, RSP and MV signal from the host computer can be assigned as desired.

Bank	Item display	Item name	Settings	Initial value
Ctrl	INP.01	PV assignment	Setting range: 0 to 3071 0: NOP	1 for loop1, 2 for loop2
	INP.02	RSP assignment	1: PV1 (input channel) 2: PV2/21(input channel)	0(NOP)
	INP.03	RMV assignment	3: PV22 (input channel) 4: Results of input computation 5: Flow rate (corrected for temperature and pressure) 6 to 2047: NOP 2048 to 3071: Standard numerical codes	0(NOP)

Auxiliary display indicates $L1$ for loop 1, and $L2$ for loop 2.

In the case of NOP (no operation), calculation is done with a fixed value of 0.0 as the data assignment.

3 - 2 Input Type

The input indication accuracy may vary depending on the type of sensor.

■ Thermocouple

P_{U-01} set value	Sensor type	Range	
1	K	-270.0 to +1372.0 °C	-454 to +2502 °F
2	E	-270.0 to +1000.0 °C	-454 to +1832 °F
3	J	-200.0 to +1200.0 °C	-328 to +2192 °F
4	T	-270.0 to +400.0 °C	-454 to +752 °F
5	B	0.0 to 1800.0 °C	32 to 3272 °F
6	R	-50.0 to +1768.0 °C	-58 to +3214 °F
7	S	-50.0 to +1768.0 °C	-58 to +3214 °F
8	WRe5-26	0.0 to 2300.0 °C	32 to 4172 °F
9	PR40-20	0.0 to 1900.0 °C	32 to 3452 °F
10	Ni-Ni-Mo	0.0 to 1300.0 °C	32 to 2372 °F
11	N	-200.0 to +1300.0 °C	-328 to +2372 °F
12	PL II	0.0 to 1390.0 °C	32 to 2534 °F
13	DIN U	-200.0 to +600.0 °C	-328 to +1112 °F
14	DIN L	-200.0 to +900.0 °C	-328 to +1652 °F
15	Gold-iron/chromel	-273.0 to +27.0 °C	-459 to +80 °F

■ Resistance temperature detector (RTD)

P_{U-01} set value	Sensor type	Range	
21	Pt100	-200.0 to +850.0 °C	-328.0 to +1562.0 °F
22		-200.0 to +300.0 °C	-328.0 to +572.0 °F
31	JPt100	-200.0 to +640.0 °C	-328.0 to +1184.0 °F
32		-200.0 to +300.0 °C	-328.0 to +572.0 °F

■ DC voltage/DC current

P_{U-01} set value	Sensor type	Range	
41	Current	4 to 20 mA	
42		0 to 20 mA	
43	Voltage	0 to 10 mV	
44		-10 to +10 mV	
45		0 to 100 mV	
46		-100 to +100 mV	
47		0 to 1 V	
48		-1 to +1 V	
49		1 to 5 V	
50		0 to 5 V	
51		0 to 10 V	

3 - 3 Computation Functions

■ Overview

The SDC45V/46V has input and output computation functions. Input computation can be used for PV processing or for switching between 2 inputs. Output computation can be used for MV processing or for switching between 2 inputs. Input and output computation are used the same way, and operate in the same way, but the timing of their execution differs.

■ Timing of execution of computational functions

[Processing flow for each sampling cycle]

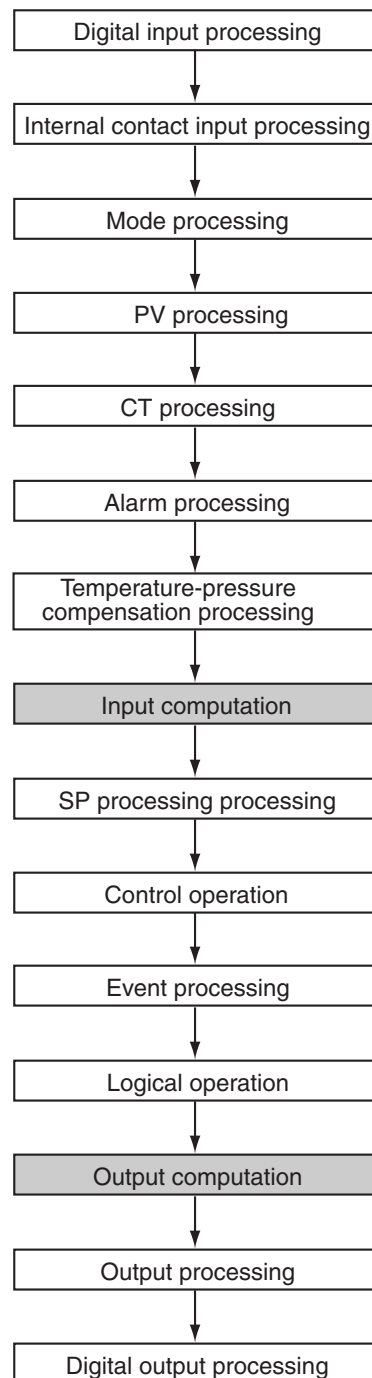

■ Computation patterns

More than twenty types of mathematical/logical operation can be assigned to up to 10 computation patterns (F1 to F10).

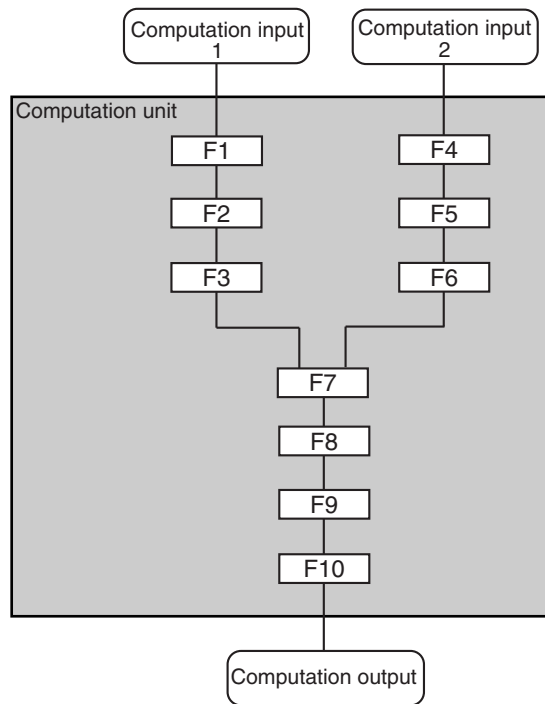

- PV and MV can be assigned to computation input 1 and computation input 2.
- Computation patterns are executed in numerical order from F1 to F10.
- Computation output is a standard numerical value.

■ Components of computation patterns (F1 to F10)

● Other than F7

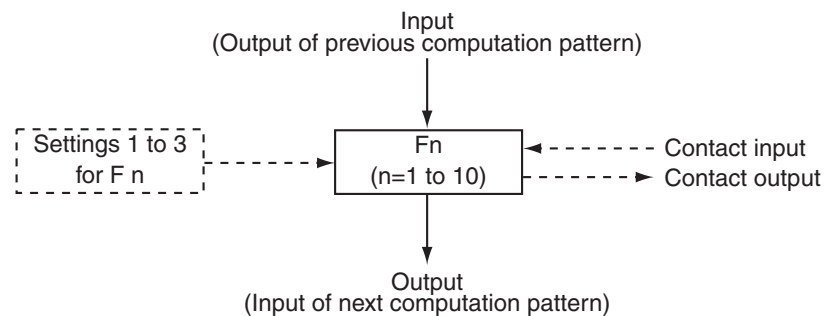

- 1-input, 1-output computation types can be assigned.
- Settings 1 to 3 are used within the computation pattern. Details differ depending on the computation type.
- Contact input is defined by a standard bit code. When ON, computation is started or stopped. Details differ depending on the computation type.
- Contact output data is used for monitoring the status of the computation. Details differ depending on the computation type.

● F7

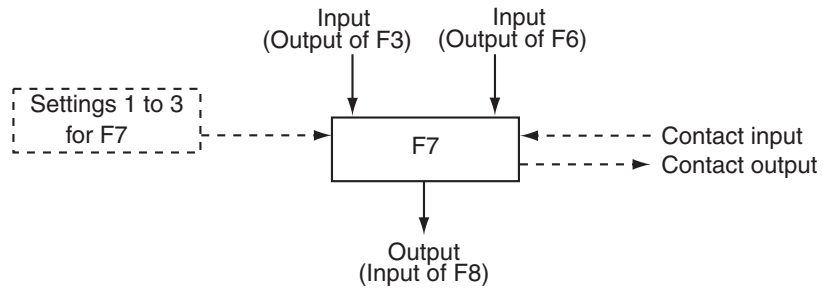

- 2-input, 1-output computations can be assigned.
- If a 1-input, 1-output computation is assigned to F7, set the operation type of operation units (F4 to F6) to NOP (no operation).

 **Note**

- When 2-input/1-output operation type is assigned to the operation units other than F7, the operation is done with the operation type = NOP (no operation).

■ **Mathematical/logical operations**

The table below lists the mathematical/logical operations and tells whether settings 1–3 and contact I/O are available (○) or not available (-) for each operation.

Bank	Display item	Item name	Descriptions	Setting 1	Setting 2	Setting 3	Contact input	Contact output
In.FnC and oE.FnC	TYPE	Mathematical/ logical operations	0:NOP No operation	-	-	-	-	-
			1:FLT First-order lag filter	○	-	-	○	-
			2:R/B Ratio/Bias	○	○	-	○	-
			3:HLL High/low limiter	○	○	-	○	○
			4:DRL Change rate limiter	○	○	○	○	○
			5:LED Differentiation	○	○	-	○	-
			6:L/L Advance/delay	○	○	-	○	-
			7:ABS Absolute value	-	-	-	○	-
			8:TBL Linearization table	-	-	○	○	-
			9:MAX Maximum value hold	-	-	-	○	-
			10:MIN Minimum value hold	-	-	-	○	-
			11:HLD Hold	-	-	-	○	-
			12:PRS Preset value	○	-	-	○	-
			13:SPR Soft preset value	○	○	○	○	-
			14 to 30:NOP No operation	-	-	-	-	-
			31:ADD Addition/subtraction	○	○	○	○	-
			32:MUL Multiplication	-	-	-	○	-
			33:DIV Division	-	-	-	○	-
			34:HSE High selector	-	-	-	○	○
			35:LSE Low selector	-	-	-	○	○
36:SWS Switch selector	-	-	-	○	○			
37:CPS Change point selector	○	○	-	○	○			
38:SSS Soft switching selector	○	-	○	○	○			

- Operations up to and including No. 30 are 1-input, 1-output.
- Operations No. 31 and following are 2-input, 1-output, and can be assigned to F7 only.

● **0: No operation (NOP)**

Setting 1: Not used.
Setting 2: Not used.
Setting 3: Not used.
Contact input: Not used.
Contact output: OFF

• **Operation details**

The input is output as is.

• **Note**

Assigned when no operation is desired. When NOP is assigned to F7, the output of F3 is output as is.

● **1: First-order lag filter (FLT)**

Setting 1: Filter constant value (setting range: 0.0 to 3200.0 s)
Setting 2: Not used.
Setting 3: Not used.
Contact input: When ON, operation is NOP (input is output as is).
Contact output: OFF

• **Operation details**

First delay operation.

● **2: Ratio/bias (R/B)**

Setting 1: Ratio (setting range: -19.999 to +32.000)
Setting 2: Bias (setting range: -19999 to +32000U, decimal point position is based on the dP setting.)
Setting 3: Not used.
Contact input: When ON, operation is NOP (input is output as is).
Contact output: OFF

• **Operation details**

Output = input x ratio + bias

• **Note**

Used also for a fixed value or for doing the four basic arithmetic operations.

● **3: High/low limiter (HLL)**

Setting 1: High limit value (setting range: -19999 to +32000U, decimal point position is based on the dP setting.)
Setting 2: Low limit value (setting range: -19999 to +32000U, decimal point position is based on the dP setting.)
Setting 3: Not used.
Contact input: When ON, operation is NOP (input is output as is).
Contact output: ON when limit reached

• **Operation details**

The input, limited as necessary by the high/low limit, is output.

If the relation of settings 1 and 2 is such that high limit < low limit, the high/low limit values are reversed before the operation is executed.

● 4: Change rate limiter (DRL)

Setting 1: Max. increase rate (setting range: 0 to 32000 U, with decimal point determined by setting 3)

Setting 2: Max. decrease rate (setting range: 0 to 32000 U, with decimal point determined by setting 3)

Setting 3: Engineering unit of change rate

0: No decimal point/s

1: No decimal point/min

2: No decimal point/h

3: 0.1/s

4: 0.1/min

5: 0.1/h

6: 0.01/s

7: 0.01/min

8: 0.01/h

9: 0.001/s

10: 0.001/min

11: 0.001/h

Contact input: When ON, the limit operation is reset.

Contact output: ON when limit reached

• Operation details

The change rate, limited as necessary by the increase/decrease limits, is output.

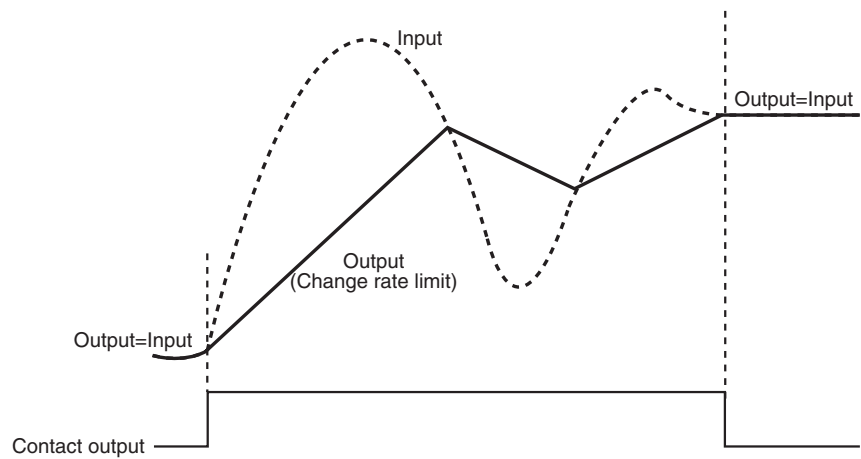

● **5: Differentiation (LED)**

- Setting 1: Advance time (setting range: 0.0 to 3200.0 s)
- Setting 2: Delay time (setting range: 0.0 to 3200.0 s)
- Setting 3: Not used.
- Contact input: When ON, output at 0.0.
- Contact output: OFF

• Operation details

$$\text{Output} = \frac{T_1 \cdot S}{1 + T_2 \cdot S} \times \text{Input}$$

(T1:Advance time T2:Delay time)

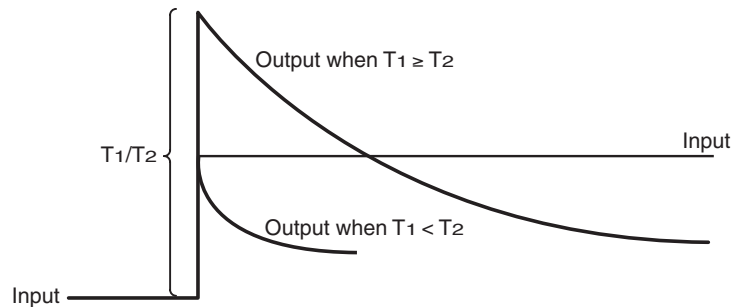

The formula shown below is used for internal computation, where T_s is the operation cycle, and $INPUT_{prev.}$ and $OUTPUT_{prev.}$ are respectively the previous input and output.

$$OUT = \frac{T_2}{T_s + T_2} \times OUTPUT_{prev.} + \frac{T_1}{T_s + T_2} \times (INPUT - INPUT_{prev.})$$

• Note:

When $T_1 > 16 \times T_2$, the calculation is automatically done as $T_1 = 16 \times T_2$.

● **6: Advance/delay (L/L)**

- Setting 1: Advance time (setting range: 0.0 to 3200.0s)
- Setting 2: Delay time (setting range: 0.0 to 3200.0s)
- Setting 3: Not used.
- Contact input: When ON, operation is NOP (input is output as is).
- Contact output: OFF

$$\text{Output} = \frac{T_1 \cdot S}{1 + T_2 \cdot S} \times \text{Input}$$

(T1:Advance time T2:Delay time)

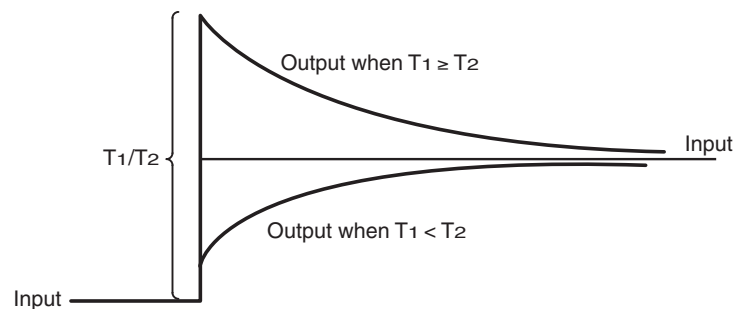

• Note:

When $T_1 > 16 \times T_2$, the calculation is automatically done as $T_1 = 16 > T_2$.

- **Absolute value (ABS)**

Setting 1: Not used.
 Setting 2: Not used.
 Setting 3: Not used.
 Contact input: When ON, operation is NOP (input is output as is).
 Contact output: OFF

- Operation details

The absolute value of the input is output.

- **8: Linearization table (TBL)**

Setting 1: Not used.
 Setting 2: Not used.
 Setting 3: Definition of linearization table (setting range: 0 to 8). When setting is 0, the input is output as is.
 Contact input: When ON, operation is NOP (input is output as is).
 Contact output: OFF

- Operation details

Linear approximation is processed using the linearization table indicated by the linearization table group definition setting.

- **9: Maximum value hold (MAX)**

Setting 1: Not used.
 Setting 2: Not used.
 Setting 3: Not used.
 Contact input: When ON, maximum value is reset.
 Contact output: OFF

- Operation details

The maximum value up to the present time is output. When the contact input is turned ON, the maximum value is reset, and output is set equal to input.

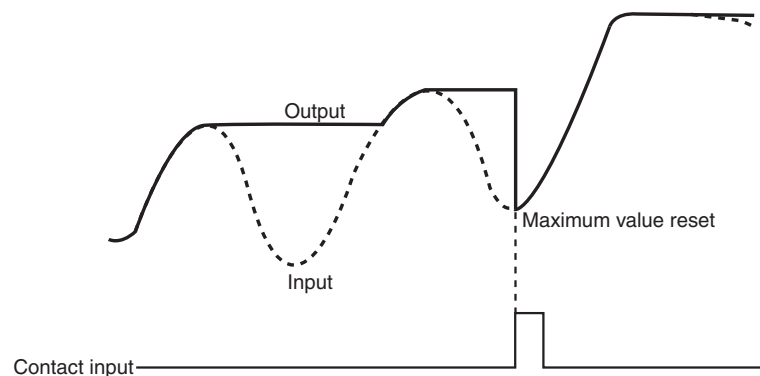

● **10: Minimum value hold (MIN)**

Setting 1: Not used.
 Setting 2: Not used.
 Setting 3: Not used.
 Contact input: When ON, minimum value is reset.
 Contact output: OFF

• **Operation details**

The minimum value up to the present time is output. When the contact input is turned ON, the minimum value is reset, and output is set equal to input.

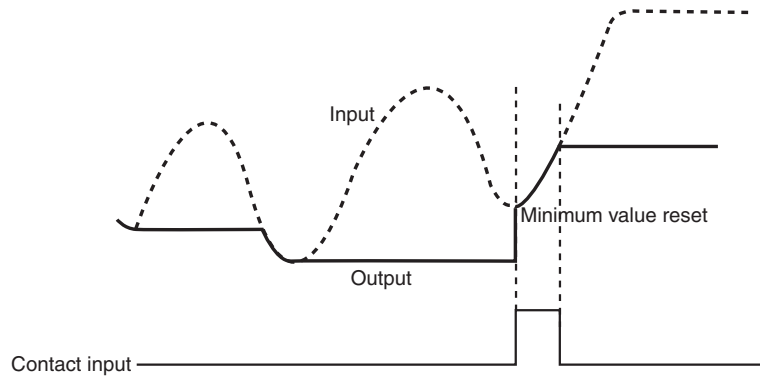

● **11: Hold (HLD)**

Setting 1: Not used.
 Setting 2: Not used.
 Setting 3: Not used.
 Contact input: When ON, continue output at the same level.
 Contact output: OFF

• **Operation details**

When contact input is ON, the output is maintained as is.
 When contact input is OFF, output is set equal to the input.

● **12: Preset value (PRS)**

Setting 1: Preset value (setting range: -19999 to +32000U, decimal point position is based on the dP setting.)
 Setting 2: Not used.
 Setting 3: Not used.
 Contact input: When ON, the preset value is output.
 Contact output: OFF

• **Operation details**

When contact input is ON, output is set equal to the preset value.
 When contact input is OFF, output is set equal to the input.

● 13: Soft (slow) preset value (SPR)

- Setting 1: Preset value (setting range: -19999 to +32000U, decimal point position is based on the dP setting.)
- Setting 2: Slope (setting range: 0 to 32000U, with decimal point determined by setting 3)
- Setting 3: Engineering unit of slope
 0:No decimal point/s
 1:No decimal point/min
 2:No decimal point/h
 3:0.1/s
 4:0.1/min
 5:0.1/h
 6:0.01/s
 7:0.01/min
 8:0.01/h
 9:0.001/s
 10:0.001/min
 11:0.001/h
- Contact input: When ON, preset value is output.
 Contact output: OFF

• Operation details

When the contact input is changed from OFF to ON, the output is set equal to the preset value during the slope operation.

If the preset value is changed while the contact input is ON, the output is set equal to the new preset value. When the contact input is OFF, output = input.

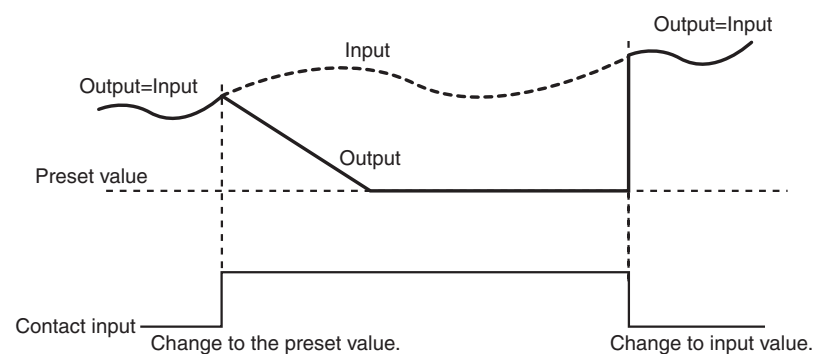

● **31: Addition/subtraction (ADD)**

Setting 1: Coefficient A(setting range: -19999 to +32000U, with decimal point determined by setting 3)

Setting 2: Coefficient B(setting range: -19999 to +32000U, with decimal point determined by setting 3)

Setting 3: Decimal point
0: No decimal point
1: 1 digit after decimal point
2: 2 digits after decimal point
3: 3 digits after decimal point
4: 4 digits after decimal point

Contact input: When ON, operation is NOP (input1 is output as is).

Contact output: OFF

• Operation details

Output = coefficient A X input 1 + coefficient B X input 2

• Note

When coefficient A = coefficient B = 0.5, the operation result is the average (arithmetic mean).

● **32: Multiplication (MUL)**

Setting 1: Not used.

Setting 2: Not used.

Setting 3: Not used.

Contact input: When ON, operation is NOP (input1 is output as is).

Contact output: OFF

• Operation details

Output = input 1 X input 2

● **33: Division (DIV)**

Setting 1: Not used.

Setting 2: Not used.

Setting 3: Not used.

Contact input: When ON, operation is NOP (input1 is output as is).

Contact output: OFF

• Operation details

Output = input 1 ÷ input 2

• Note

When the input 2 is set equal to 0, not operated (input 1 is output as is).

● **34: High selector (HSE)**

Setting 1: Not used.

Setting 2: Not used.

Setting 3: Not used.

Contact input: When ON, operation is NOP (input1 is output as is).

Contact output: OFF when input 1 is output, and ON when input 2 is output.

• Operation details

After comparison of input 1 and input 2, the larger one is output.

● **35: Low selector (LSE)**

Setting 1: Not used.

Setting 2: Not used.

Setting 3: Not used.

Contact input: When ON, operation is NOP (input1 is output as is).

Contact output: OFF when input 1 is output, and ON when input 2 is output.

• Operation details

After comparison of input 1 and input 2, the smaller one is output.

● **36: Switch selector (SWS)**

Setting 1: Not used.

Setting 2: Not used.

Setting 3: Not used.

Contact input: When OFF, input 1 is output. When ON, input 2 is output.

Contact output: OFF when input 1 is output, and ON when input 2 is output.

• Operation details

When contact input is OFF, input 1 is output.

When contact input is ON, input 2 is output.

● **37: Change point selector (CPS)**

Setting 1: Change point (setting range: -19999 to +32000U, decimal point position is based on the dP setting.)

Setting 2: Hysteresis (setting range: 0 to 32000U, decimal point position is based on the dP setting.)

Setting 3: Not used.

Contact input: When ON, operation is NOP (input1 is output as is).

Contact output: OFF when input 1 is output, and ON when input 2 is output.

• Operation details

If input 1 is equal to or greater than the change point, the output is set equal to input 2. Afterwards, if input 1 is less than change point - hysteresis, the output is set equal to input 1.

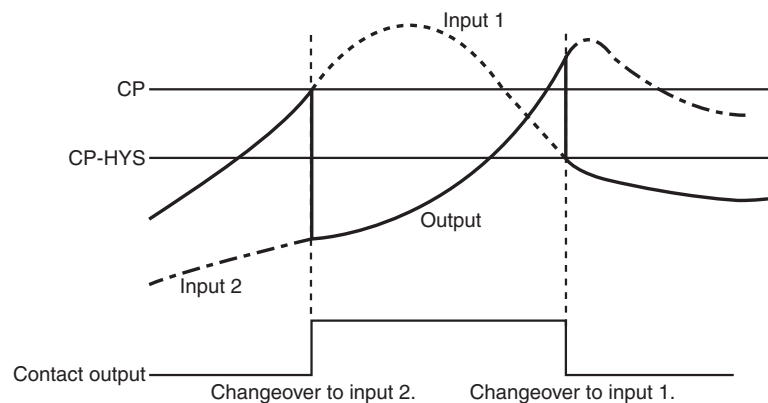

● **38: Soft (slow) switching selector (SSS)**

- Setting 1: Slope (setting range: 0 to 32000U, with decimal point determined by setting 3)
- Setting 2: Not used.
- Setting 3: Engineering unit of slope
 - 0 : No decimal point/s
 - 1 : No decimal point/min
 - 2 : No decimal point/h
 - 3 : 0.1/s
 - 4 : 0.1/min
 - 5 : 0.1/h
 - 6 : 0.01/s
 - 7 : 0.01/min
 - 8 : 0.01/h
 - 9 : 0.001/s
 - 10 : 0.001/min
 - 11 : 0.001/h

Contact input: When OFF, input 1 is output. When ON, input 2 is output.

Contact output: OFF when input 1 is output, ON when input 2 is output, and OFF when during the interchange.

• **Operation details**

When the contact input is OFF, input 1 is output. When the contact input is ON, input 2 is output. Input 1 and input 2 are interchanged during the slope operation.

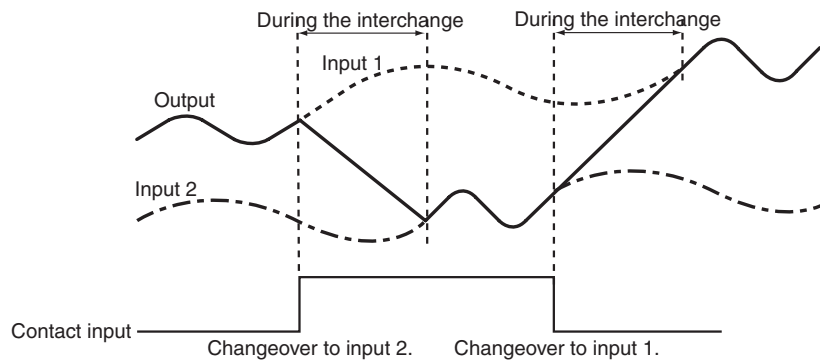

■ Important supplemental information

● High/low limits

- Range limits of settings

For settings 1 to 3, the setting range (high/low limit value) differs according to the mathematical/logical operations. If the set value exceeds the allowable range, the operation is carried out using the highest/lowest allowable value.

Mathematical/logical operations	High/low limit in internal operations		
	Setting 1 (PR-01)	Setting 2 (PR-02)	Setting 3 (PR-03)
0:NOP No operation	-	-	-
1:FLT First-order lag filter	0.0 to 3200.0 s	-	-
2:R/B Ratio/bias	-19.999 to + 32.000	-19999 to + 32000 U	-
3:HLL High/low limiter	-19999 to + 32000 U	-19999 to + 32000 U	-
4:DRL Change rate limiter	0 to 32000 U	0 to 32000 U	0 to 11
5:LED Differentiation	0.0 to 3200.0 s	0.0 to 3200.0 s	-
6:L/L Advance/delay	0.0 to 3200.0 s	0.0 to 3200.0 s	-
7:ABS Absolute value	-	-	-
8:TBL Linearization table	-	-	0 to 8 *
9:MAX Maximum value hold	-	-	-
10:MIN Minimum value hold	-	-	-
11:HLD Hold	-	-	-
12:PRS Preset value	-19999 to + 32000 U	-	-
13:SPR Soft preset value	-19999 to + 32000 U	0 to 32000 U	0 to 11
14 to 30: NOP No operation	-	-	-
31:ADD Addition/subtraction	-19999 to + 32000 U	-19999 to + 32000U	0 to 4
32:MUL Multiplication	-	-	-
33:DIV Division	-	-	-
34:HSE High selector	-	-	-
35:LSE Low selector	-	-	-
36:SWS Switch selector	-	-	-
37:CPS Change point selector	-19999 to +32000 U	0 to 32000 U	-
38:SSS Soft switching selector	0 to 32000 U	-	0 to 11

*: If the high/low limit is exceeded, the operation is carried out with a setting of "0".

A blank box in the table indicates nonuse for the operation type. In this case, the setting range accessed by communications is as follows:

Setting 1: -19999 to + 32000

Setting 2: -19999 to + 32000

Setting 3: 0 to 255

- Limits of operation processing

The computation unit does not do any limit processing on the operation result.

The user can set limits as necessary using the high/low limiter (HLL).

● **Initialization of operation unit**

In the following cases, the internal data of all operation units is initialized (reset):

- When the power is turned on.
- When the loop type setting (L-00) in the setup bank (SETP) is changed.

● **Operation accuracy**

Operations are performed with a single-precision floating point decimal.

3 - 4 Power Failure Detection

■ Overview

The occurrence/nonoccurrence of a power supply interruption can be checked. In addition, when a startup method and hot start power failure high limit have been set, the SDC45V/46V can use the hot start function.

■ Bank and settings

Bank	Item display	Item name	Settings	Initial value	Remarks
SEtUP	℄-017	Startup method	0: Cold start 1: Hot start	0	
	℄-018	Max. power failure time for hot start	5 to 32000s	5	Can be set if the startup method is set to hot start.
	℄-019	Power failure detection	(Can be write 0 only) 0: No power interruption 1: Power interrupted in excess of cold start or else hot start power failure upper limit time. 2: Power interrupted for less than the hot start power failure upper limit time.	-	When power is restored after a power failure, the device can be set automatically to 1 or 2. The user can change the setting only to 0.

■ Measurement of power failure time

When the startup method (℄-017) is set to 1 (hot start), the duration of the power failure is measured by the device as shown in the figure below.

The result of comparison between the duration of the power failure and the value set for hot start power failure upper limit time (℄-018) is shown by the power failure detection function (℄-019).

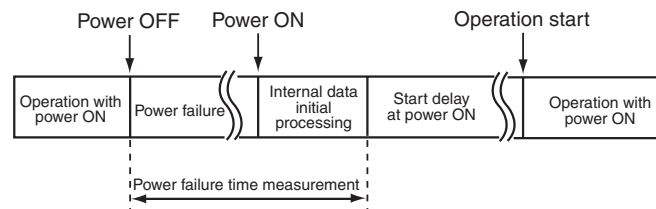

■ Note

- Time required for initial processing of internal device data is 5 s max.

■ How to check for power failure

After power is restored, the occurrence of a power failure is shown in ℄-019 (power failure detection) in the setup bank (SEtUP).

℄-019 is set to 2 (power interrupted for less than the hot start power failure upper limit time) only when the following conditions are satisfied:

- When the startup method (℄-017) is set to 1 (hot start).
- When power is restored after a power failure that does not last as long as the hot start power failure upper limit time (℄-018).

In addition, power failure information (℄-019) is reflected as a standard bit code (power failure detection). Internal contact input and logical operations can be utilized for processing of a power failure recovery.

■ **How to reset the power failure detection**

Power failure detection (CF-019) can be reset to 0. A connected host device can check the power supply status by setting CF-019 to 0 and then monitoring its value. To turn the standard bit (power failure detection) OFF, set power failure detection (CF-019) to 0.

3 - 5 Hot Start

The SDC45V/46V has a hot start function. When hot start is used, and power is restored after a power failure, control operation starts from the MV in use when the power failure occurred, and control fluctuation is kept to a minimal level.

■ How to use the function

Set the startup method ($\zeta-017$) in the setup bank (*SETUP*) to 1 (hot start). To define a maximum power failure time for a hot start, set the hot start power failure upper limit time ($\zeta-018$).

■ Conditions for hot start

A: Immediately after recovery from power failure, the power failure detection ($\zeta-019$) value is 2 (power failure for a time less than the hot start power failure upper limit time).

B: AUTO-RUN status (MV = PID control output)

C: MANUAL mode both before power failure and just after the recovery from power failure.

Under the following combinations of conditions, a hot start is used.

- When conditions A and B are both met.
- When conditions A and C are both met.

When power is restored after a power failure and the conditions are other than the above combinations, a hot start is not used.

■ Operating specifications

- When conditions A and B are met.
Control operation starts using the MV (PID control output) in use before the power failure as the initial output of PID control. Bumpless initialization keeps any undesired control operation at a minimum.
- When conditions A and C are realized.
The manual MV in use before the power failure is continuously output.

■ Backed up data

The data backed up when the power fails is the MV calculated for control.
The internal data used in the control calculation is not backed up.

■ How to check the status of hot start and reset

Status can be checked for each loop by the standard bit code for PID hot start detection. To turn the PID hot start detection bit OFF, set power failure detection ($\zeta-019$) to 0.

3 - 6 Temperature-Pressure Correction

■ 2 inputs model

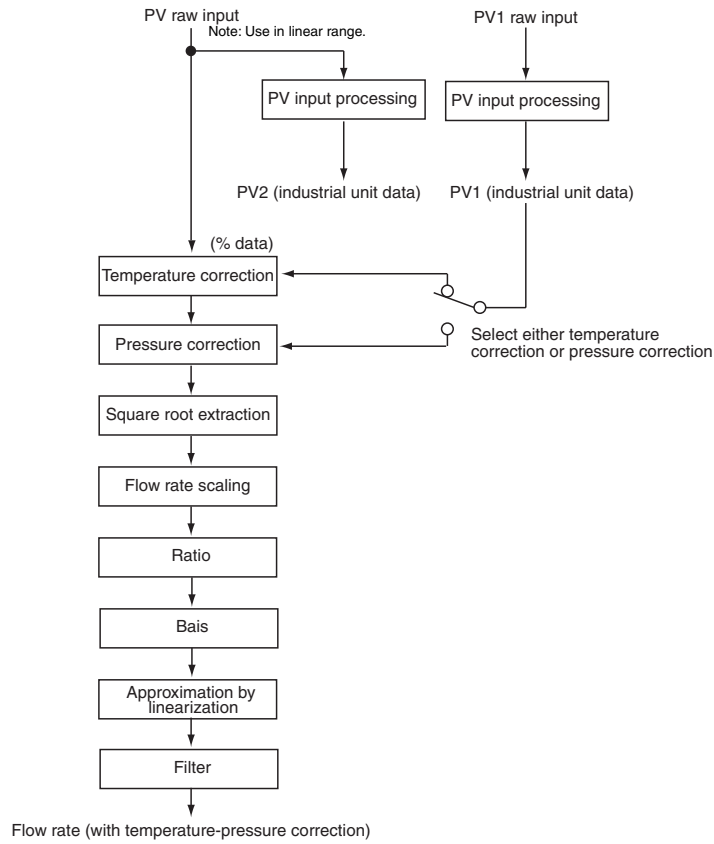

■ 3 inputs model

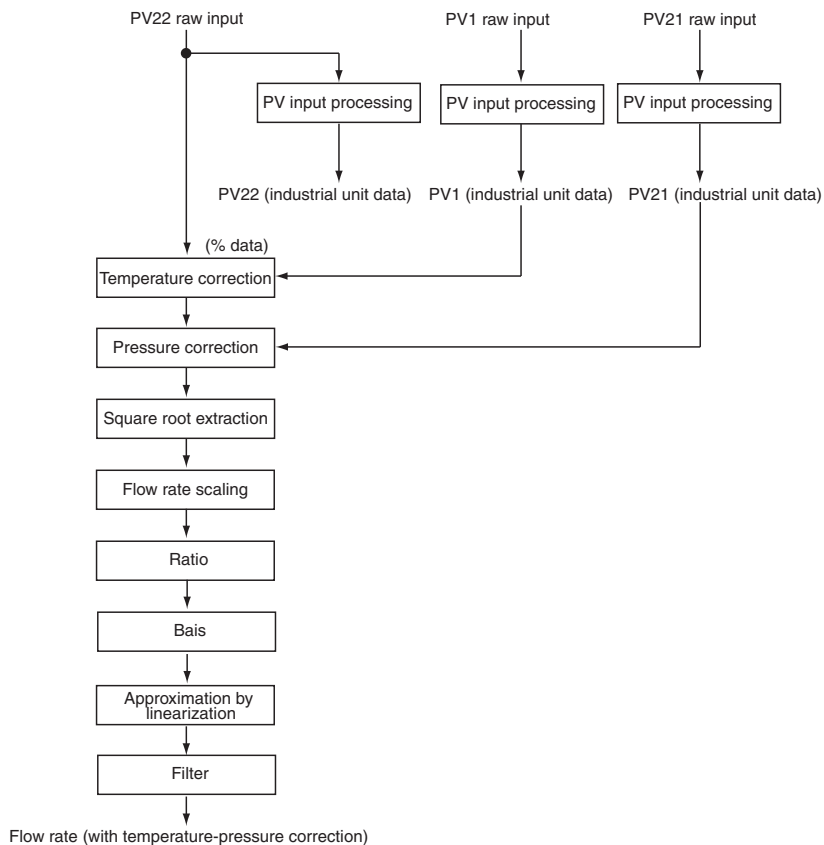

■ Temperature correction

For the flow rate signal, the equation below is used for temperature correction.

$$\text{Corrected flow rate signal (\%)} = \frac{\text{Design temperature} + \text{CV}^*}{\text{PV input for temp. correction} + \text{CV}^*} \times \text{Flow rate signal (\%)}$$

*: Where CV is a constant.

The decimal point for design temperature is set by the decimal point position (P_{v-02}) assigned for temperature correction in the PV input bank (P_v).

The constant CV is the following values depending on the temperature unit:

Temperature unit	Constant value (CV)
Celsius	273.15
Fahrenheit	459.67
K (Kelvin)	0.0

The temperature unit is determined by the following settings:

PV range type assigned for temperature correction	Temperature unit
For thermocouple or RTD	The temperature unit (P_{v-03}) selected in the PV bank (P_v)
For linear (DC) range	Unit selected for temperature correction (P_{v-02}) in the temperature-pressure correction bank (P_{v-04})

■ Pressure correction

For the flow rate signal, the equation below is used for pressure correction.

$$\text{Corrected flow rate signal (\%)} = \frac{\text{PV input for pressure correction} + \text{CP}^*}{\text{Design pressure} + \text{CP}^*} \times \text{Flow rate signal (\%)}$$

*: Where CP is a constant.

The decimal point for design pressure is set by the decimal point position (P_{v-02}) assigned for pressure correction in the PV input bank (P_v).

The unit of pressure is set by the pressure unit (P_{v-04}) assigned in the temperature-pressure correction bank (P_{v-04}).

The constant CP is the values shown below, depending on the pressure unit:

Pressure unit	CP
MPa	0.101325
kPa	101.325
Pa	101325
kg/cm ²	1.03323
mmH ₂ O	10332.3

■ Flow rate scaling

The temperature-pressure correction, as well as a corrected flow rate signal (%) with square root extraction, are scaled based on the low limit (0%) and high limit (100%) settings.

■ **Operating specifications if settings are abnormal**

Under the conditions specified below, temperature-pressure correction is not done.
The flow rate (with temperature-pressure correction) is 0.0.

- When the input of flow rate signal is not a linear range (D.C.).
- When the input of pressure signal is not a linear range.
- When the correction method (P.T.C.T) on the 2-input model is set to 3 (temperature-pressure correction).

Chapter 4. SAMPLE SETTINGS

This chapter gives examples of settings configured using the SLP-C45 Smart Loader Package.

● Example 1: Calculation of PV from 2 PV inputs

- Electric power control for heater

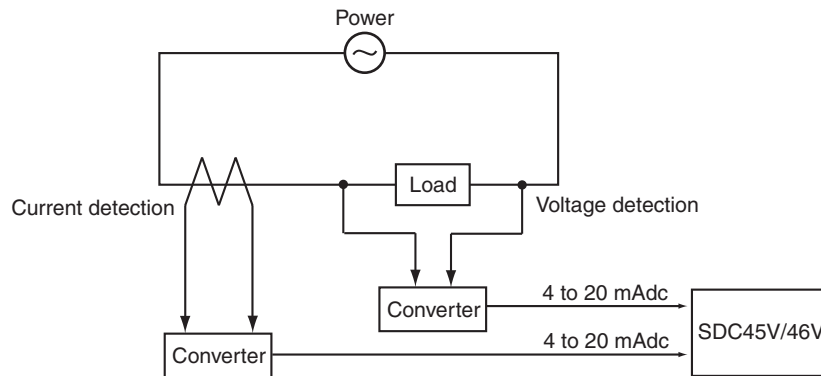

- Signal flow

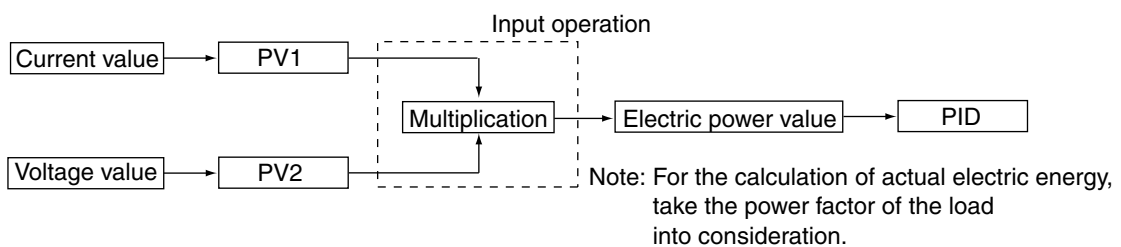

* The product of input 1 X input 2 is used as the PV value for PID calculation.

- Settings

(1) Select [Setup] → [Loop type (C-001)], and set to [0:1 loop].

(2) Select [PV], and set PV1 and PV2 for current and voltage ranges respectively.

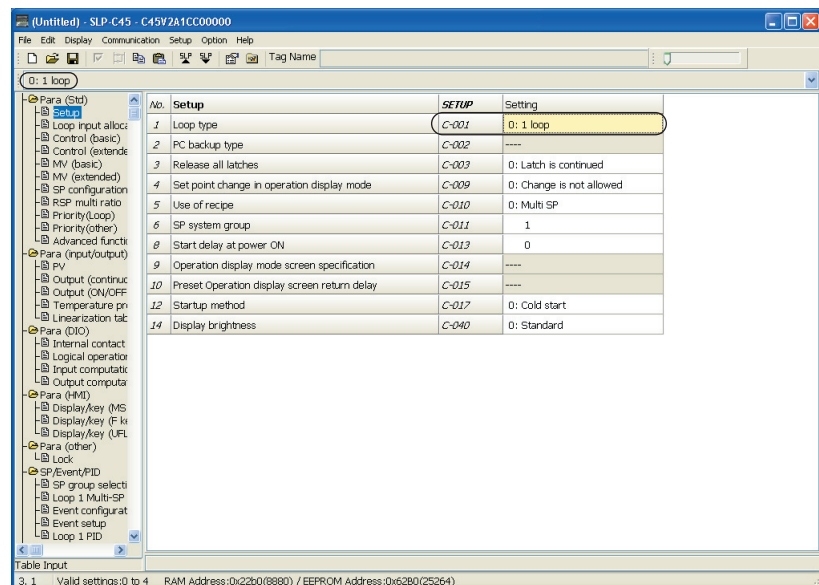

- (3) Select [Input computation], and set [Input 1] and [Input 2] in F1 to [2304: PV1] and [2305: PV2/PV21] respectively.

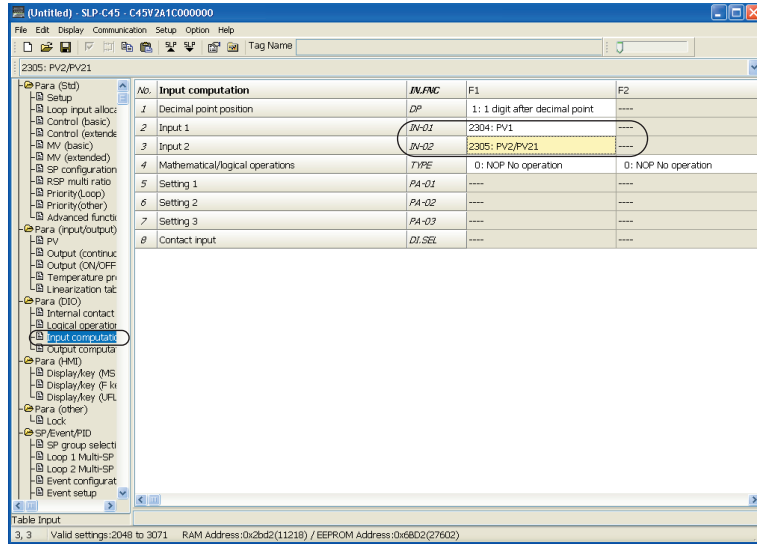

- (4) Select [Operation [F7]], and set the [Mathematical/logical operations] to [32: MUL Multiplication].

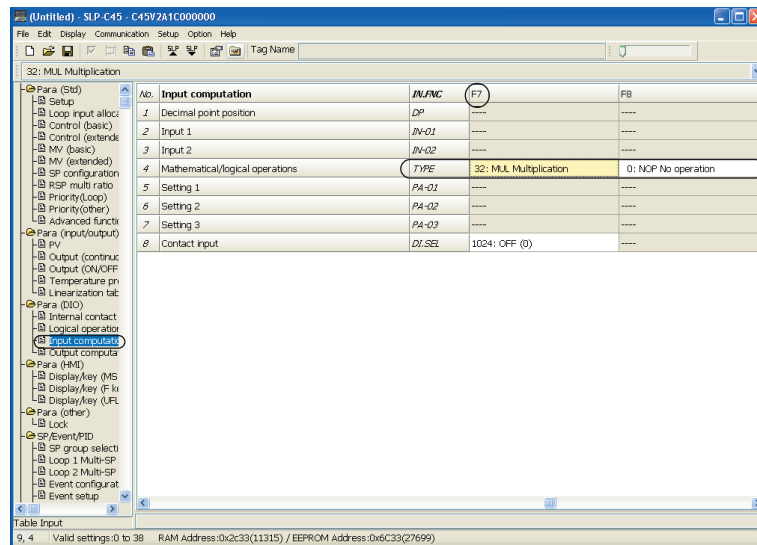

(5) Select [Loop input allocation], and set [PV assignment] to [4: Results of input computation].

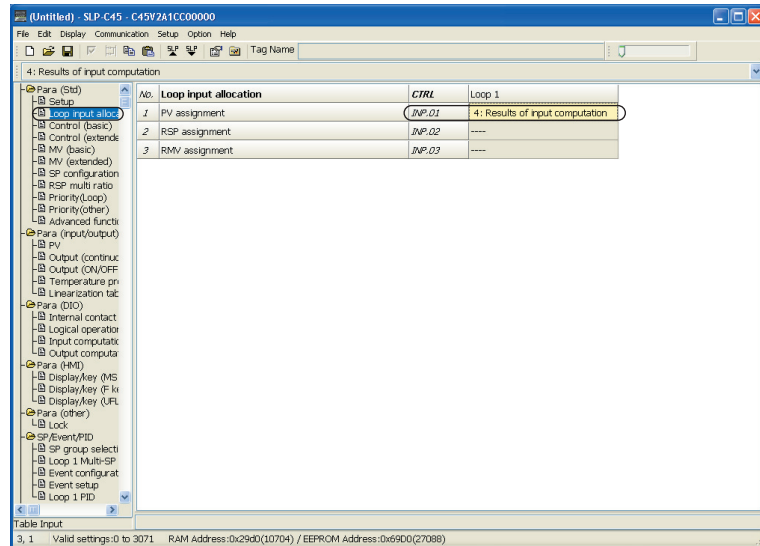

>>The settings are used in the input computation as follows:

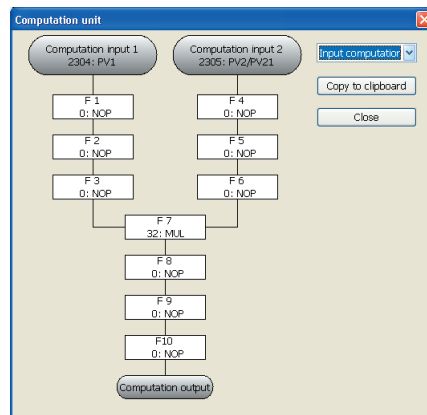

● **Example 2: Control one actuator continuously while switching between 2 inputs**

- Electric power control for heater

Switching between sensors using different industrial units (pressure to temperature, current to temperature)

- Signal flow

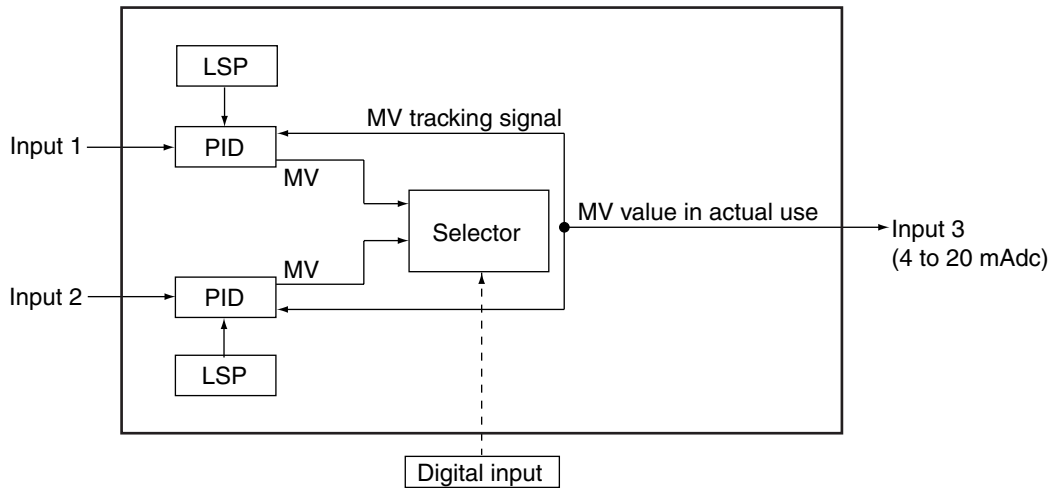

Note: With an MV tracking signal, bumpless control (without control output irregularity) can be continued even if inputs 1 and 2 are switched. For digital input, use No. 1 of line F.

- Signal flow

- (1) Select [Setup] → [Loop type (C-001)], and set to [1: 2 loops (independent)].
- (2) Select [PV], and set the input ranges for PV1 and PV2.

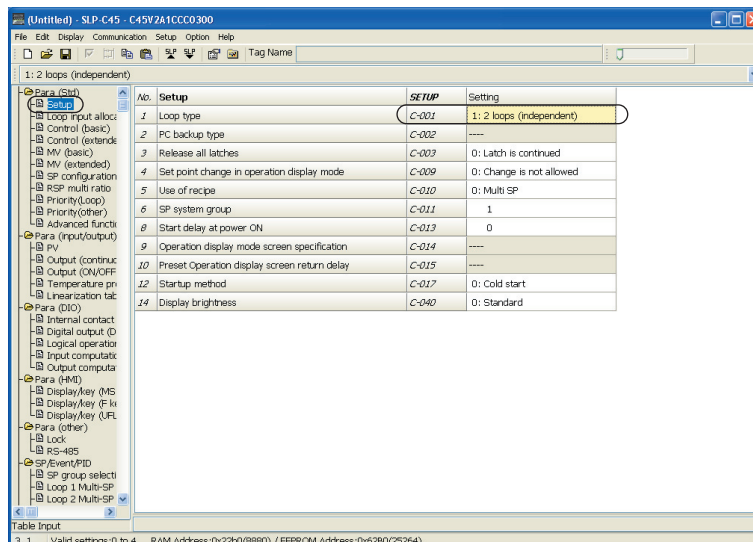

- (3) Select [Loop input allocation], and assign [1: PV1] and [2: PV2] to [Loop 1] and [Loop 2] respectively.

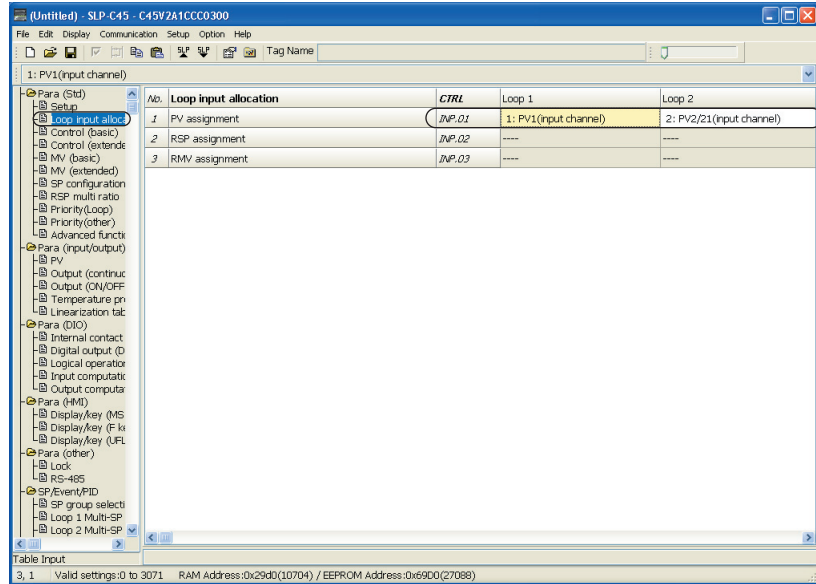

- (4) Select [MV (extended)], and set the [MV tracking selection (digital)] to [1025: ON] for both loops 1 and 2.

- (5) Set [MV tracking analog signal type] to [2624: Output computation result] for both loops 1 and 2.

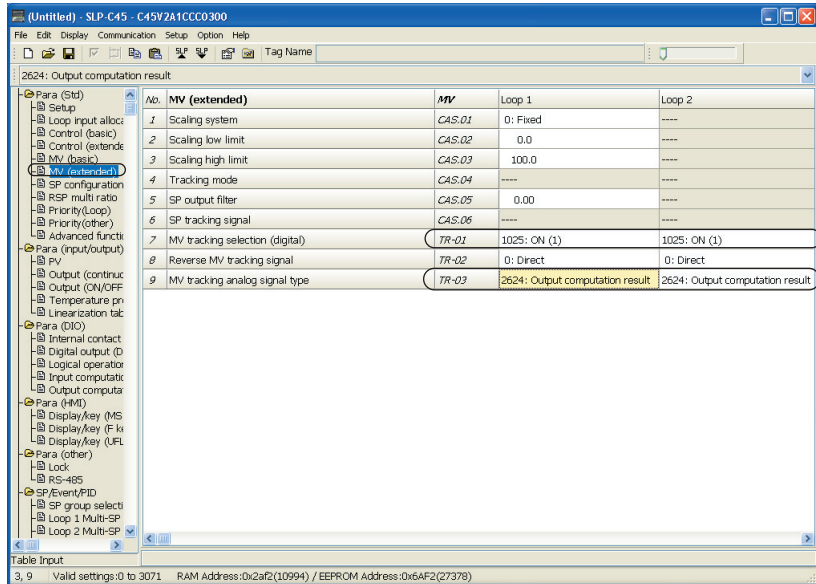

- (6) Select [Output computation], and for [Operation F1] assign [2416: MV of loop 1] and [2417: MV of loop 2] to [Input 1] and [Input 2] respectively.

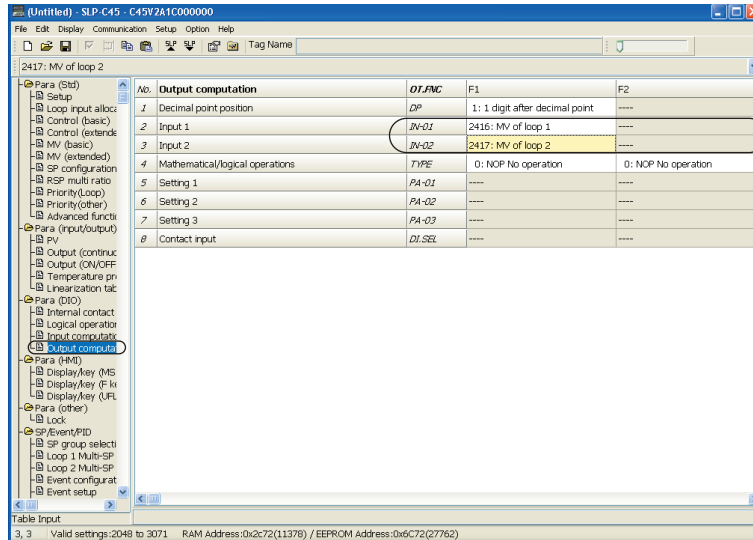

- (7) Select [Operation [F7]], and assign [36: SWS Switch selector] to [Mathematical/logical operations].

- (8) Set [Contact input] to [1176: Terminal status of DI-F1].

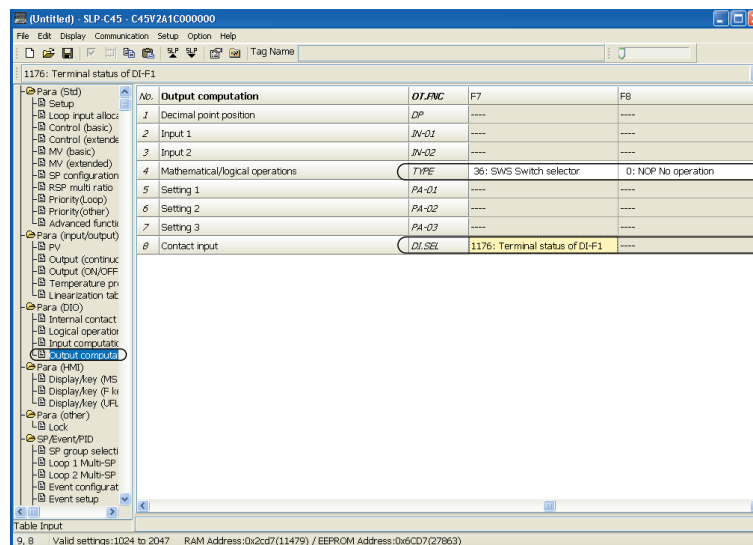

- (9) Select [Output (continuous output)] and set [Output type] to [2624: Output computation result].

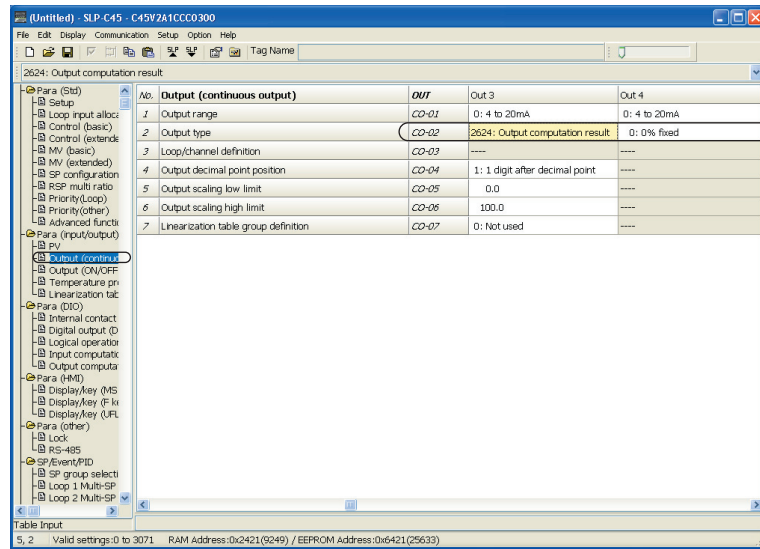

>>The settings are used as follows in the output computation:

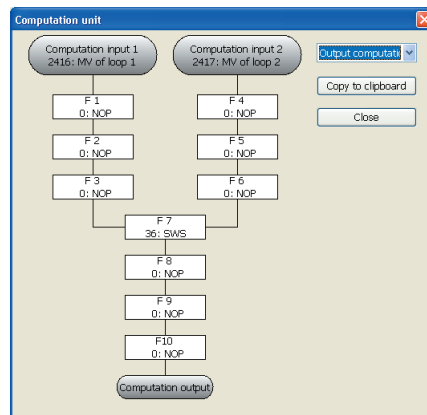

Chapter 5. ALARM CODE LIST

Alarm code	Failure name	Cause	Corrective action
<i>R101</i>	PV1 input over-range failure	Sensor burnout, incorrect wiring, incorrect PV1 range type setting.	Check the wiring, reset PV1 range type (<i>Pv-01</i>) or reset PV1 range upper/lower value. (<i>Pv-04</i> : range lower value, <i>Pv-05</i> : range upper value.)
<i>R102</i>	PV1 input under-range failure		
<i>R103</i>	PV2/PV21 input over-range failure	Sensor burnout, incorrect wiring, incorrect PV2/PV21 range type setting.	Check the wiring, reset PV2/PV21 range type (<i>Pv-02</i>) or reset PV2/PV21 range upper/lower value.(<i>Pv-04</i> : range lower value, <i>Pv-05</i> : range upper value.)
<i>R104</i>	PV2/PV21 input under-range failure		
<i>R105</i>	PV22 input over-range failure	Sensor burnout, incorrect wiring, incorrect PV22 range type setting.	Check the wiring, reset PV22 range type (<i>Pv-03</i>) or reset PV22range upper/lower value. (<i>Pv-04</i> : range lower value, <i>Pv-05</i> : range upper value.)
<i>R106</i>	PV22 input under-range failure		
<i>R121</i>	MFB input failure	Burnout, incorrect wiring.	Check the wiring.
<i>R122</i>	Motor adjustment failure	Burnout, incorrect wiring, Motor power shutdown.	Readjust the motor after checking the wiring and motor power.
<i>R125</i>	CT1 input failure	CT input over-range	•Check CT input.
<i>R126</i>	CT2 input failure	Incorrect CT range type setting.	•Reset CT input.
<i>R171</i>	Abnormal PV1 CJ compensation	Abnormal terminal temperature. (thermocouple)	Check the ambient temperature.
<i>R172</i>	Abnormal PV2 CJ compensation		
<i>R181</i>	Battery low (only SDC45V/46V)	Dead battery	Replace the battery.
<i>R182</i>	Internal clock failure (only SDC45V/46V)	Dead battery, Hardware failure.	Reset the clock after battery is replaced. Replace the unit.
<i>R183</i>	Board configuration problem	Hardware failure.	Replace the unit.
<i>R195</i>	Main board failure		
<i>R197</i>	Parameter failure	•Power was turned OFF while setting data. •Data is corrupted due to noise, etc.	Restart the system. Reset data or replace the unit. (<i>R197</i> : setting data, <i>R198</i> : adjustment data)
<i>R198</i>	Adjustment data problem		
<i>R199</i>	ROM failure	ROM (memory) is faulty.	Restart the system. Replace the unit.

Chapter 6. LIST OF SETTING DATA AND COMMUNICATION DATA

6 - 1 Control Bank (Ctrl)

Display	Loop number (auxiliary display)	Item	Settings and descriptions	Initial value	User setting	Remarks
inP.01	L.1.	PV assignment	0: NOP 1: PV1 (input channel) 2: PV2/21 (input channel)	1		•Can be set from 0 to 3071, but many numbers are undefined and should not be used. For details, see the Standard Numerical Codes list. •Cannot be set on the SDC45A/46A.
inP.02	L.1.	RSP assignment	3: PV22 (input channel) 4: Results of input computation	0		
inP.03	L.1.	RMV assignment	5: Flow rate (corrected for temperature and pressure) Note: For other settings, see remarks in far right column.	0		
Ctrl.01	L.1.	Loop PV/SP decimal point position	0: No decimal point 1: 1 digit after decimal point 2: 2 digits after decimal point 3: 3 digits after decimal point 4: 4 digits after decimal point	1		
Ctrl.03	L.1.	Control action	0: Reverse (heat) 1: Direct (cool) 2: Heat/cool	0		
Ctrl.04	L.1.	Control algorithm	0: PID-A (deviation derivative) 1: Ra-PID 2: PID-B (PV derivative)	0		
Ctrl.05	L.1.	Control range low limit	-19999 to +32000 U	0		The decimal point position is determined by the decimal point positions for the loop PV/SP.
Ctrl.06	L.1.	Control range high limit		1000		
Ctrl.07	L.1.	AT type	0: Normal (regular control characteristics) 1: Immediate response (control characteristics for fast response to external disturbance) 2: Stable (control characteristics that minimize up/down PV fluctuation)	0		
Ctrl.08	L.1.	Heat/cool control dead zone	-100.0 to +100.0 %	0.0		
Ctrl.09	L.1.	Initial PID control output	-10.0 to +110.0 %	0.0		
Ctrl.10	L.1.	Abnormal PV definition	0: If a PV alarm (AL01 to AL06) occurs 1: If a PV1 alarm (AL01 or AL02) occurs 2: If a PV2/21 alarm (AL03 or AL04) occurs 3: If a PV22 alarm (AL05 or AL06) occurs	0		Cannot be set on the SDC45A/46A.
Etd.01	L.1.	PID control initialization	0: Auto 1: Not initialized 2: Initialized (if SP value different from the current value is input)	0		
Etd.02	L.1.	Integral time/derivative time decimal point position	0: No decimal point 1: 1 digit after decimal point 2: 2 digits after decimal point	0		Affected by the decimal point positions for integral time and derivative time.
Etd.03	L.1.	Output after AUTO • MANUAL change	0: Bumpless transfer 1: Preset	0		
Etd.04	L.1.	Preset MANUAL value	-10.0 to +110.0 %	0.0		When the power is turned ON, if the operation mode is MANUAL, the MV is preset MANUAL value.
Etd.05	L.1.	MV increase change limit	0.00: No limit	0.00		
Etd.06	L.1.	MV decrease change limit	0.01 to 320.00 %/s	0.00		
Etd.07	L.1.	Heat/cool selection	0: Normal 1: Energy saving	0		
Etd.08	L.1.	MV low limit for AT	-10.0 to +110.0 %	0.0		
Etd.09	L.1.	MV high limit for AT		100.0		
Etd.12	L.1.	Zone operation selection	0: Selected by SP value 1: Selected by PV value	0		If zone PID is used, set the PID group selection priority to "Zone PID function".
Etd.13	L.1.	Zone 1	-19999 to +32000 U	3200.0		The decimal point position is determined by the decimal point positions for the loop PV/SP.
Etd.14	L.1.	Zone 2				
Etd.15	L.1.	Zone 3				
Etd.16	L.1.	Zone 4				
Etd.17	L.1.	Zone 5				
Etd.18	L.1.	Zone 6				
Etd.19	L.1.	Zone 7				
Etd.20	L.1.	Zone hysteresis	0 to 32000 U	5.0		
inP.01	L.2.	PV assignment	0: NOP 1: PV1 (input channel) 2: PV2/21 (input channel)	2		•Can be set from 0 to 3071, but many numbers are undefined and should not be used. For details, see the Standard Numerical Codes list. •Cannot be set on the SDC45A/46A.
inP.02	L.2.	RSP assignment	3: PV22 (input channel) 4: Results of input computation	-		
inP.03	L.2.	RMV assignment	5: Flow rate (corrected for temperature and pressure) Note: For other settings, see remarks in far right column.	-		
Ctrl.01	L.2.	Loop PV/SP decimal point position	0: No decimal point 1: 1 digit after decimal point 2: 2 digits after decimal point 3: 3 digits after decimal point 4: 4 digits after decimal point	1		

Chapter 6. LIST OF SETTING DATA AND COMMUNICATION DATA

Display	Loop number (auxiliary display)	Item	Settings and descriptions	Initial value	User setting	Remarks
CnE.03	L.2.	Control action	0: Reverse (heat) 1: Direct (cool) 2: Heat/cool	0		
CnE.04	L.2.	Control algorithm	0: PID-A (deviation derivative) 1: Ra-PID 2: PID-B (PV derivative)	0		
CnE.05	L.2.	Control range low limit	-19999 to +32000 U	0		The decimal point position is determined by the decimal point positions for the loop PV/SV.
CnE.06	L.2.	Control range high limit		1000.0		
CnE.07	L.2.	AT type	0: Normal (regular control characteristics) 1: Immediate response (control characteristics for fast response to external disturbance) 2: Stable (control characteristics that minimize up/down PV fluctuation)	0		
CnE.08	L.2.	Heat/cool control dead zone	-100.0 to +100.0 %	0.0		
CnE.09	L.2.	Initial PID control output	-10.0 to +110.0 %	0.0		
CnE.10	L.2.	Abnormal PV definition	0: If a PV alarm (AL01 to AL06) occurs 1: If a PV1 alarm (AL01 or AL02) occurs 2: If a PV2/21 alarm (AL03 or AL04) occurs 3: If a PV22 alarm (AL05 or AL06) occurs	0		Cannot be set on the SDC45A/46A.
Etd.01	L.2.	PID control initialization	0: Auto 1: Not initialized 2: Initialized (if SP value different from the current value is input)	0		
Etd.02	L.2.	Integral time/derivative time decimal point position	0: No decimal point 1: 1 digit after decimal point 2: 2 digits after decimal point	0		Affected by the decimal point positions for integral time and derivative time.
Etd.03	L.2.	Output after AUTO • MANUAL change	0: Bumpless transfer 1: Preset	0		
Etd.04	L.2.	Preset MANUAL value	-10.0 to +110.0 %	0.0		When the power is turned ON, if the operation mode is MANUAL, the MV is preset MANUAL value.
Etd.05	L.2.	MV increase change limit	0.00: No limit	0.00		
Etd.06	L.2.	MV decrease change limit	0.01 to 320.00 %/s	0.00		
Etd.07	L.2.	Heat/cool selection	0: Normal 1: Energy saving	0		
Etd.08	L.2.	MV low limit for AT	-10.0 to +110.0 %	0.0		
Etd.09	L.2.	MV high limit for AT		100.0		
Etd.12	L.2.	Zone operation selection	0: Selected by SP value 1: Selected by PV value	0		If zone PID is used, set the PID group selection priority to "Zone PID function".
Etd.13	L.2.	Zone 1	-19999 to +32000 U	3200.0		The decimal point position is determined by the decimal point positions for the loop PV/SP.
Etd.14	L.2.	Zone 2				
Etd.15	L.2.	Zone 3				
Etd.16	L.2.	Zone 4				
Etd.17	L.2.	Zone 5				
Etd.18	L.2.	Zone 6				
Etd.19	L.2.	Zone 7				
Etd.20	L.2.	Zone hysteresis	0 to 32000 U	5.0		

6 - 2 Temperature-Pressure Correction Bank (Pv.CnP)

Display	Loop number (auxiliary display)	Item	Settings and descriptions	Initial value	User setting	Remarks
Pv.C.01		Compensation method	0: No compensation 1: Temperature compensation 2: Pressure compensation 3: Temperature and pressure compensation	0		
Pv.C.02		Unit for temperature correction	0: Celsius (°C) 1: Fahrenheit (°F) 2: Kelvin (K)	0		Setting cannot be changed if PV1 is a thermocouple or RTD.
Pv.C.03		Design temperature for temperature correction	-1999.9 to +3200.0	0.0		
Pv.C.04		Unit for pressure correction	0: MPa 1: kPa 2: Pa 3: kg/cm ² 4: mmH ₂ O	0		
Pv.C.05		Design pressure for pressure correction	-1999.9 to +3200.0	0.0		
Pv.C.06		Decimal point position (for flow rate setting)	0: No decimal point 1: 1 digit after decimal point 2: 2 digits after decimal point 3: 3 digits after decimal point 4: 4 digits after decimal point	1		
Pv.C.07		Flow rate scaling low limit	-19999 to +32000	0.0		The decimal point position is determined by the decimal
Pv.C.08		Flow rate scaling high limit		100.0		point position for the flow rate setting.
Pv.C.09		Square root extraction dropout	0.0: Square root extraction is not used. 0.1 to 10.0 %	0.0		
Pv.C.10		Filter	0.00: No filter 0.01 to 120.00 s	0.0		
Pv.C.11		Bias	-19999 to +32000	0.0		
Pv.C.12		Ratio	0.001 to 32.000	1.000		
Pv.C.13		Linearization table group definition	0: Not used 1: Group 1 2: Group 2 3: Group 3 4: Group 4 5: Group 5 6: Group 6 7: Group 7 8: Group 8	0		

6 - 3 Input Computation Bank (Input)

Display	Loop number (auxiliary display)	Item	Settings and descriptions	Initial value	User setting	Remarks
dP	F01	Decimal point position	0: No decimal point 1: 1 digit after decimal point 2: 2 digits after decimal point 3: 3 digits after decimal point 4: 4 digits after decimal point	1		
In.01	F01	Input 1	2048 to 3071	2048		See the Standard Numerical Codes list.
In.02	F01	Input 2		2048		
TYPE	F01	Mathematical/logical operations	0:NOP No operation 1:FLT First-order lag filter 2:R/B Ratio/bias 3:HLL High/low limiter 4:DRL Change rate limiter 5:LED Differentiation 6:L/L Advance/delay 7:ABS Absolute value 8:TBL Linearization table 9:MAX Maximum value hold 10:MIN Minimum value hold 11:HLD Hold 12:PRS Preset value 13:SPR Soft preset value	0		
PR-01	F01	Setting 1	-19999 to +32000 U	0.0		The decimal point position is determined by the setting for the decimal point position in the input computation bank.
PR-02	F01	Setting 2		0.0		
PR-03	F01	Setting 3		0		
d1.SEL	F01	Contact input	1024 to 2047	1024		See the Standard Numerical Codes list.
d1	F01	Contact input monitor	0:OFF 1:ON	-		
do	F01	Contact output monitor		-		
oUt	F01	Computation unit output check point value	-19999 to +32000 U	-		The decimal point position is determined by the setting for the decimal point position in the input computation bank.
TYPE	F02	Mathematical/logical operations	Same as for F01.	0		Same as for F01.
PR-01	F02	Setting 1		0.0		
PR-02	F02	Setting 2		0.0		
PR-03	F02	Setting 3		0		
d1.SEL	F02	Contact input		1024		
d1	F02	Contact input monitor		-		
do	F02	Contact output monitor		-		
oUt	F02	Computation unit output check point value		-		
TYPE	F03	Mathematical/logical operations		Same as for F01.	0	
PR-01	F03	Setting 1		0.0		
PR-02	F03	Setting 2		0.0		
PR-03	F03	Setting 3		0		
d1.SEL	F03	Contact input		1024		
d1	F03	Contact input monitor		-		
do	F03	Contact output monitor		-		
oUt	F03	Computation unit output check point value		-		
TYPE	F04	Mathematical/logical operations		Same as for F01.	0	
PR-01	F04	Setting 1		0.0		
PR-02	F04	Setting 2		0.0		
PR-03	F04	Setting 3		0		
d1.SEL	F04	Contact input		1024		
d1	F04	Contact input monitor		-		
do	F04	Contact output monitor		-		
oUt	F04	Computation unit output check point value		-		
TYPE	F05	Mathematical/logical operations		Same as for F01.	0	
PR-01	F05	Setting 1		0.0		
PR-02	F05	Setting 2		0.0		
PR-03	F05	Setting 3		0		
d1.SEL	F05	Contact input		1024		
d1	F05	Contact input monitor		-		
do	F05	Contact output monitor		-		
oUt	F05	Computation unit output check point value		-		

Chapter 6. LIST OF SETTING DATA AND COMMUNICATION DATA

Display	Loop number (auxiliary display)	Item	Settings and descriptions	Initial value	User setting	Remarks
TYPE	F06.	Mathematical/logical operations	Same as for F01.	0		Same as for F01.
PR-01	F06.	Setting 1		0.0		
PR-02	F06.	Setting 2		0.0		
PR-03	F06.	Setting 3		0		
dI.SEL	F06.	Contact input		1024		
dI	F06.	Contact input monitor		-		
dO	F06.	Contact output monitor		-		
oUt	F06.	Computation unit output check point value		-		
TYPE	F07.	Mathematical/logical operations	0:NOP No operation 1:FLT First-order lag filter 2:R/B Ratio/bias 3:HLL High/low limiter 4:DRL Change rate limiter 5:LED Differentiation 6:L/L Advance/delay 7:ABS Absolute value 8:TBL Linearization table 9:MAX Maximum value hold 10:MIN Minimum value hold 11:HLD Hold 12:PRS Preset value 13:SPR Soft preset value 14 to 30: No operation 31:ADD Addition/subtraction 32:MUL Multiplication 33:DIV Division 34:HSE High selector 35:LSE Low selector 36:SWS Switch selector 37:CPS Change point selector 38:SSS Soft switching selector	0		14 to 38 can be set with computation unit 07 only.
PR-01	F07.	Setting 1	-19999 to +32000 U	0.0		The decimal point position is determined by the setting for the decimal point position in the input computation bank.
PR-02	F07.	Setting 2		0.0		
PR-03	F07.	Setting 3	0 to 255	0		
dI.SEL	F07.	Contact input	1024 to 2047	1024		See the Standard Numerical Codes list.
dI	F07.	Contact input monitor	0: OFF 1: ON	-		
dO	F07.	Contact output monitor		-		
oUt	F07.	Computation unit output check point value	-19999 to +32000 U	-		The decimal point position is determined by the setting for the decimal point position in the input computation bank.
TYPE	F08.	Mathematical/logical operations	Same as for F01.	0		Same as for F01.
PR-01	F08.	Setting 1		0.0		
PR-02	F08.	Setting 2		0.0		
PR-03	F08.	Setting 3		0		
dI.SEL	F08.	Contact input		1024		
dI	F08.	Contact input monitor		-		
dO	F08.	Contact output monitor		-		
oUt	F08.	Computation unit output check point value		-		
TYPE	F09.	Mathematical/logical operations	Same as for F01.	0		Same as for F01.
PR-01	F09.	Setting 1		0.0		
PR-02	F09.	Setting 2		0.0		
PR-03	F09.	Setting 3		0		
dI.SEL	F09.	Contact input		1024		
dI	F09.	Contact input monitor		-		
dO	F09.	Contact output monitor		-		
oUt	F09.	Computation unit output check point value		-		
TYPE	F10.	Mathematical/logical operations	Same as for F01.	0		Same as for F01.
PR-01	F10.	Setting 1		0.0		
PR-02	F10.	Setting 2		0.0		
PR-03	F10.	Setting 3		0		
dI.SEL	F10.	Contact input		1024		
dI	F10.	Contact input monitor		-		
dO	F10.	Contact output monitor		-		
oUt	F10.	Computation unit output check point value		-		

6 - 4 Output Computation Bank (ok.Fnc)

Display	Loop number (auxiliary display)	Item	Settings and descriptions	Initial value	User setting	Remarks
dP	F01	Decimal point position	0: No decimal point 1: 1 digit after decimal point 2: 2 digits after decimal point 3: 3 digits after decimal point 4: 4 digits after decimal point	1		
In.01	F01	Input 1	2048 to 3071	2048		See the Standard Numerical Codes list.
In.02	F01	Input 2		2048		
TYPE	F01	Mathematical/logical operations	0:NOP No operation 1:FLT First-order lag filter 2:R/B Ratio/bias 3:HLL High/low limiter 4:DRL Change rate limiter 5:LED Differentiation 6:L/L Advance/delay 7:ABS Absolute value 8:TBL Linearization table 9:MAX Maximum value hold 10:MIN Minimum value hold 11:HLD Hold 12:PRS Preset value 13:SPR Soft preset value	0		
PR-01	F01	Setting 1	-19999 to +32000 U	0.0		The decimal point position is determined by the setting for the decimal point position in the input computation bank.
PR-02	F01	Setting 2		0.0		
PR-03	F01	Setting 3		0		
d1.SEL	F01	Contact input	1024 to 2047	1024		See the Standard Numerical Codes list.
d1	F01	Contact input monitor	0:OFF 1:ON	-		
do	F01	Contact output monitor		-		
oUt	F01	Computation unit output check point value	-19999 to +32000 U	-		The decimal point position is determined by the setting for the decimal point position in the input computation bank.
TYPE	F02	Mathematical/logical operations	Same as for F01.	0		Same as for F01.
PR-01	F02	Setting 1		0.0		
PR-02	F02	Setting 2		0.0		
PR-03	F02	Setting 3		0		
d1.SEL	F02	Contact input		1024		
d1	F02	Contact input monitor		-		
do	F02	Contact output monitor		-		
oUt	F02	Computation unit output check point value		-		
TYPE	F03	Mathematical/logical operations	Same as for F01.	0		Same as for F01.
PR-01	F03	Setting 1		0.0		
PR-02	F03	Setting 2		0.0		
PR-03	F03	Setting 3		0		
d1.SEL	F03	Contact input		1024		
d1	F03	Contact input monitor		-		
do	F03	Contact output monitor		-		
oUt	F03	Computation unit output check point value		-		
TYPE	F04	Mathematical/logical operations	Same as for F01.	0		Same as for F01.
PR-01	F04	Setting 1		0.0		
PR-02	F04	Setting 2		0.0		
PR-03	F04	Setting 3		0		
d1.SEL	F04	Contact input		1024		
d1	F04	Contact input monitor		-		
do	F04	Contact output monitor		-		
oUt	F04	Computation unit output check point value		-		
TYPE	F05	Mathematical/logical operations	Same as for F01.	0		Same as for F01.
PR-01	F05	Setting 1		0.0		
PR-02	F05	Setting 2		0.0		
PR-03	F05	Setting 3		0		
d1.SEL	F05	Contact input		1024		
d1	F05	Contact input monitor		-		
do	F05	Contact output monitor		-		
oUt	F05	Computation unit output check point value		-		

Chapter 6. LIST OF SETTING DATA AND COMMUNICATION DATA

Display	Loop number (auxiliary display)	Item	Settings and descriptions	Initial value	User setting	Remarks
TYPE	F06.	Mathematical/logical operations	Same as for F01.	0		Same as for F01.
PR-01	F06.	Setting 1		0.0		
PR-02	F06.	Setting 2		0.0		
PR-03	F06.	Setting 3		0		
d1.SEL	F06.	Contact input		1024		
d1	F06.	Contact input monitor		-		
do	F06.	Contact output monitor		-		
oUt	F06.	Computation unit output check point value		-		
TYPE	F07.	Mathematical/logical operations	0:NOP No operation 1:FLT First-order lag filter 2:R/B Ratio/bias 3:HLL High/low limiter 4:DRL Change rate limiter 5:LED Differentiation 6:L/L Advance/delay 7:ABS Absolute value 8:TBL Linearization table 9:MAX Maximum value hold 10:MIN Minimum value hold 11:HLD Hold 12:PRS Preset value 13:SPR Soft preset value 14 to 30: No operation 31:ADD Addition/subtraction 32:MUL Multiplication 33:DIV Division 34:HSE High selector 35:LSE Low selector 36:SWS Switch selector 37:CPS Change point selector 38:SSS Soft switching selector	0		14 to 38 can be set with computation unit 07 only.
PR-01	F07.	Setting 1	-19999 to +32000 U	0.0		The decimal point position is determined by the setting for the decimal point position in the input computation bank.
PR-02	F07.	Setting 2		0.0		
PR-03	F07.	Setting 3	0 to 255	0		
d1.SEL	F07.	Contact input	1024 to 2047	1024		See the Standard Numerical Codes list.
d1	F07.	Contact input monitor	0: OFF 1: ON	-		
do	F07.	Contact output monitor		-		
oUt	F07.	Computation unit output check point value	-19999 to +32000 U	-		The decimal point position is determined by the setting for the decimal point position in the input computation bank.
TYPE	F08.	Mathematical/logical operations	Same as for F01.	0		Same as for F01.
PR-01	F08.	Setting 1		0.0		
PR-02	F08.	Setting 2		0.0		
PR-03	F08.	Setting 3		0		
d1.SEL	F08.	Contact input		1024		
d1	F08.	Contact input monitor		-		
do	F08.	Contact output monitor		-		
oUt	F08.	Computation unit output check point value		-		
TYPE	F09.	Mathematical/logical operations	Same as for F01.	0		Same as for F01.
PR-01	F09.	Setting 1		0.0		
PR-02	F09.	Setting 2		0.0		
PR-03	F09.	Setting 3		0		
d1.SEL	F09.	Contact input		1024		
d1	F09.	Contact input monitor		-		
do	F09.	Contact output monitor		-		
oUt	F09.	Computation unit output check point value		-		
TYPE	F10.	Mathematical/logical operations	Same as for F01.	0		Same as for F01.
PR-01	F10.	Setting 1		0.0		
PR-02	F10.	Setting 2		0.0		
PR-03	F10.	Setting 3		0		
d1.SEL	F10.	Contact input		1024		
d1	F10.	Contact input monitor		-		
do	F10.	Contact output monitor		-		
oUt	F10.	Computation unit output check point value		-		

6 - 5 List of Communication Data

The following shows the meanings of the symbols stated in the "RAM/EEPROM Read/Write" columns:

- No symbol : Possible.
- : Possible according to the conditions.
- △ : Possible, but data is invalid.
- × : Impossible.

! Handling Precautions

- When reading the EEPROM address, data in the RAM is read in the same manner as reading of the RAM address.

Decimal point information

- : No decimal point
- 1 to 3: Decimal point position (original value of data is multiplied by 10, 100, or 1000)
- LP1 and 2: Determined by the settings for the loop 1 or loop 2 in the control bank ("loop PV/SV decimal point position").
- PV1 and 2: Determined by the settings for PV1 or PV2 in the PV bank ("decimal point position").
- RMP1 and 2: Determined by the settings for loop 1 or loop 2 in the SP configuration bank ("SP ramp unit").
- PID1 and 2: Determined by the settings for loop 1 or loop 2 in the control bank ("integral time/derivative time decimal point position").
- OUT1 to 7: Determined by the settings for outputs 1 through 7 in the output bank ("output decimal point position").
- EV1 to 7: Determined by the settings for event Nos. 1 through 16 in the event configuration bank ("decimal point position").
- Linearizations 1 to 8: Determined by the settings for Linearizations 1 through 8 in the Linearization table bank ("breakpoint decimal point position").
- MS1 to 3: Determined by the settings for priorities 1 through 3 in the display/key bank ("MS display decimal point position").
- PV22: Determined by the decimal point position setting for PV22 in the PV bank.
- FL: Determined by the setting in the temperature-pressure correction bank for decimal point position (for flow rate setting).
- I-F: Determined by the setting for decimal point position in the input computation bank.
- I-F01 to I-F10: Determined by the mathematical/logical operation type of computation patterns F01 to F10 in the input computation bank.
- O-F: Determined by the setting for decimal point position in the output computation bank.
- O-F01 to O-F10: Determined by the mathematical/logical operation type of computation units F01 to F10 in the output computation bank.

RD/WD/RU/WU commands of CPL communication:

- Use hexadecimal data addresses.

Chapter 6. LIST OF SETTING DATA AND COMMUNICATION DATA

Bank name	No.	Item name	RAM address Hexadecimal	EEPROM address Hexadecimal	RAM		EEPROM		Decimal point information	Remarks
					Read	Write	Read	Write		
Control	Loop 1	Abnormal PV definition	1F79	5F79					-	
	Loop 2	Abnormal PV definition	1F89	5F89					-	
	Loop 1	PV assignment	29D0	69D0					-	
		RSP assignment	29D1	69D1					-	
		RMV assignment	29D2	69D2					-	
	Loop 2	PV assignment	29E0	69E0					-	
		RSP assignment	29E1	69E1					-	
RMV assignment		29E2	29E2					-		
MV	Loop 1	SP tracking signal	2AD5	6AD5					-	
		MV tracking selection	2AF0	6AF0					-	
		Reverse MV tracking signal	2AF1	6AF1					-	
		MV tracking analog signal type	2AF2	6AF2					-	
	Loop 2	SP tracking signal	2ADD	6ADD					-	
		MV tracking selection	2AF8	6AF8					-	
		Reverse MV tracking signal	2AF9	6AF9					-	
		MV tracking analog signal type	2AFA	6AFA					-	
Setup		Set point change in operation display mode	2270	6270					-	
		Operation display mode screen specification	2275	6275					-	
		Preset Operation display screen return delay	2276	6276					-	
		Power supply frequency	2277	6277					-	
		Startup method	2278	6278					-	Cannot be read/written on the SDC45A/46A.
		Max. power failure time for hot start	2279	6279					-	
		Power failure detection	227A	627A					-	
		Year	228C	628C					-	Cannot be read/written on the SDC45A/46A.
		Month/day	228D	628D					-	
	Hour/minute	228E	628E					-		
Priority		Operation display changeover	2312	6312					-	
		Linearization group table for position proportional control	2313	6313					-	
PV	PV22	Range type	2380	6380					-	Cannot be written on the SDC45A/46A.
		Decimal point position	2381	6381					-	
		Temperature unit	2382	6382					-	Can be set on the 3-input model of SDC45V/46V.
		Range low limit	2383	6383					PV22	
		Range high limit	2384	6384					PV22	
		(Cold junction compensation)	2385	6385					-	
		(Zener barrier adjustment)	2386	6386					2	
		(Reserved for future use.)	2387	6387	×	×	×	×	-	
		Linear scaling low limit	2388	6388					PV22	
		Linear scaling high limit	2389	6389					PV22	
		Square root extraction dropout	238A	638A					1	
		Filter	238B	638B					2	
		Bias	238C	638C					PV22	
Ratio	238D	638D					3			

Chapter 6. LIST OF SETTING DATA AND COMMUNICATION DATA

Bank name	No.	Item name	RAM address Hexadecimal	EEPROM address Hexadecimal	RAM		EEPROM		Decimal point information	Remarks
					Read	Write	Read	Write		
PV	PV22	(Reserved for future use.)	238E	638E	×	×	×	×	-	Cannot be written on the SDC45A/46A. Can be set on the 3-input model of SDC 45V/46V.
		Thermocouple-mV input burnout	238F	638F					-	
		(Reserved for future use.)	2390	6390	×	×	×	×	-	
		(Reserved for future use.)	2391	6391	×	×	×	×	-	
		(Reserved for future use.)	2392	6392	×	×	×	×	-	
		Linearization table group definition	2393	6393					-	
Position proportional		Output type	24E0	64E0					-	
		Control method selection	24E1	64E1					-	
		Dead zone	24E2	64E2					1	
		Long service life	24E3	64E3					-	
		Automatic adjustment	24E4	64E4					-	
		Fully closed calibration value	24E5	64E5					-	
		Fully open calibration value	24E6	64E6					-	
		Time to open fully (calibration value)	24E7	64E7					1	
		Loop designation	24E8	64E8					-	
		Linearization table group definition	24E9	64E9					-	
Temperature-pressure correction		Compensation method	2AB0	6AB0					-	Cannot be read/written on the SDC45A/46A.
		Unit for temperature correction	2AB1	6AB1					-	
		Design temperature for temperature correction	2AB2	6AB2					1	
		Unit for pressure correction	2AB3	6AB3					-	
		Design pressure for pressure correction	2AB4	6AB4					1	
		Decimal point position (for flow rate setting)	2AB5	6AB5					-	
		Flow rate scaling low limit	2AB6	6AB6					FL	
		Flow rate scaling high limit	2AB7	6AB7					FL	
		Square root extraction dropout	2AB8	6AB8					1	
		Filter	2AB9	6AB9					2	
		Bias	2ABA	6ABA					FL	
		Ratio	2ABB	6ABB					3	
	Linearization table group definition	2ABC	6ABC					-		
CT input	CT1	CT type	2B90	6B90					-	
		CT measurement wait time	2B91	6B91					-	
		Number of CT turns	2B92	6B92					-	
		Number of CT power wire loops	2B93	6B93					-	
		Heater burnout detection current value	2B94	6B94					1	
		Over-current detection current value	2B95	6B95					1	
		Short-circuit detection current value	2B96	6B96					1	
		Hysteresis	2B97	6B97					1	
		Delay time	2B98	6B98					1	
		Condition for restoration of unmeasured value	2B99	6B99					-	

Chapter 6. LIST OF SETTING DATA AND COMMUNICATION DATA

Bank name	No.	Item name	RAM address Hexadecimal	EEPROM address Hexadecimal	RAM		EEPROM		Decimal point information	Remarks
					Read	Write	Read	Write		
CT input	CT2	CT type	2BA0	6BA0					-	
		CT measurement wait time	2BA1	6BA1					-	
		Number of CT turns	2BA2	6BA2						
		Number of CT power wire loops	2BA3	6BA3					-	
		Heater burnout detection current value	2BA4	6BA4					1	
		Over-current detection current value	2BA5	6BA5					1	
		Short-circuit detection current value	2BA6	6BA6					1	
		Hysteresis	2BA7	6BA7					1	
		Delay time	2BA8	6BA8					1	
		Condition for restoration of unmeasured value	2BA9	6BA9					-	
Input operation	F01	Decimal point position	2BD0	6BD0					-	Cannot be read/ written on the SDC45A/46A.
		Input 1	2BD1	6BD1					-	
		Input 2	2BD2	6BD2					-	
		Mathematical/logical operations	2BD3	6BD3					-	
		Setting 1	2BD4	6BD4					I-F01	
		Setting 2	2BD5	6BD5					I-F01	
		Setting 3	2BD6	6BD6					I-F01	
		Contact input	2BD7	6BD7					-	
		Contact input monitor	2BD8	6BD8			×	×	-	
		Contact output monitor	2BD9	6BD9			×	×	-	
	Operation unit output checkpoint value	2BDA	6BDA			×	×	I-F		
	F02	Mathematical/logical operations	2BE3	6BE3					-	
		Setting 1	2BE4	6BE4					I-F02	
		Setting 2	2BE5	6BE5					I-F02	
		Setting 3	2BE6	6BE6					I-F02	
		Contact input	2BE7	6BE7					-	
		Contact input monitor	2BE8	6BE8			×	×	-	
		Contact output monitor	2BE9	6BE9			×	×	-	
	Operation unit output checkpoint value	2BEA	6BEA			×	×	I-F		
	F03	Mathematical/logical operations	2BF3	6BF3					-	
		Setting 1	2BF4	6BF4					I-F03	
		Setting 2	2BF5	6BF5					I-F03	
		Setting 3	2BF6	6BF6					I-F03	
		Contact input	2BF7	6BF7					-	
		Contact input monitor	2BF8	6BF8			×	×	-	
		Contact output monitor	2BF9	6BF9			×	×	-	
	Operation unit output checkpoint value	2BFA	6BFA			×	×	I-F		
	F04	Mathematical/logical operations	2C03	6C03					-	
		Setting 1	2C04	6C04					I-F04	
		Setting 2	2C05	6C05					I-F04	
Setting 3		2C06	6C06					I-F04		
Contact input		2C07	6C07					-		
Contact input monitor		2C08	6C08			×	×	-		
Contact output monitor		2C09	6C09			×	×	-		
Operation unit output checkpoint value	2C0A	6C0A			×	×	I-F			

Chapter 6. LIST OF SETTING DATA AND COMMUNICATION DATA

Bank name	No.	Item name	RAM address	EEPROM address	RAM		EEPROM		Decimal point information	Remarks	
			Hexadecimal	Hexadecimal	Read	Write	Read	Write			
Input operation	F05	Mathematical/logical operations	2C13	6C13					-	Cannot be read/written on the SDC45A/46A.	
		Setting 1	2C14	6C14					I-F05		
		Setting 2	2C15	6C15					I-F05		
		Setting 3	2C16	6C16					I-F05		
		Contact input	2C17	6C17					-		
		Contact input monitor	2C18	6C18			×		×		-
		Contact output monitor	2C19	6C19			×		×		-
	Operation unit output checkpoint value	2C1A	6C1A			×		×	I-F		
	F06	Mathematical/logical operations	2C23	6C23					-		
		Setting 1	2C24	6C24					I-F06		
		Setting 2	2C25	6C25					I-F06		
		Setting 3	2C26	6C26					I-F06		
		Contact input	2C27	6C27					-		
		Contact input monitor	2C28	6C28			×		×		-
		Contact output monitor	2C29	6C29			×		×		-
	Operation unit output checkpoint value	2C2A	6C2A			×		×	I-F		
	F07	Mathematical/logical operations	2C33	6C33					-		
		Setting 1	2C34	6C34					I-F07		
		Setting 2	2C35	6C35					I-F07		
		Setting 3	2C36	6C36					I-F07		
		Contact input	2C37	6C37					-		
		Contact input monitor	2C38	6C38			×		×		-
		Contact output monitor	2C39	6C39			×		×		-
	Operation unit output checkpoint value	2C3A	6C3A			×		×	I-F		
	F08	Mathematical/logical operations	2C43	6C43					-		
		Setting 1	2C44	6C44					I-F08		
		Setting 2	2C45	6C45					I-F08		
		Setting 3	2C46	6C46					I-F08		
		Contact input	2C47	6C47					-		
		Contact input monitor	2C48	6C48			×		×		-
		Contact output monitor	2C49	6C49			×		×		-
	Operation unit output checkpoint value	2C4A	6C4A			×		×	I-F		
	F09	Mathematical/logical operations	2C53	6C53					-		
		Setting 1	2C54	6C54					I-F09		
		Setting 2	2C55	6C55					I-F09		
		Setting 3	2C56	6C56					I-F09		
		Contact input	2C57	6C57					-		
		Contact input monitor	2C58	6C58			×		×		-
		Contact output monitor	2C59	6C59			×		×		-
	Operation unit output checkpoint value	2C5A	6C5A			×		×	I-F		
	F10	Mathematical/logical operations	2C63	6C63					-		
		Setting 1	2C64	6C64					I-F10		
Setting 2		2C65	6C65					I-F10			
Setting 3		2C66	6C66					I-F10			
Contact input		2C67	6C67					-			
Contact input monitor		2C68	6C68			×		×	-		
Contact output monitor		2C69	6C69			×		×	-		
Operation unit output checkpoint value	2C6A	6C6A			×		×	I-F			

Chapter 6. LIST OF SETTING DATA AND COMMUNICATION DATA

Bank name	No.	Item name	RAM address Hexadecimal	EEPROM address Hexadecimal	RAM		EEPROM		Decimal point information	Remarks	
					Read	Write	Read	Write			
Output operation	F01	Decimal point position	2C70	6C70					-	Cannot be read/ written on the SDC45A/46A.	
		Input 1	2C71	6C71					-		
		Input 2	2C72	6C72					-		
		Mathematical/logical operations	2C73	6C73					-		
		Setting 1	2C74	6C74					O-F01		
		Setting 2	2C75	6C75					O-F01		
		Setting 3	2C76	6C76					O-F01		
		Contact input	2C77	6C77					-		
		Contact input monitor	2C78	6C78			×		×		-
		Contact output monitor	2C79	6C79			×		×		-
	Operation unit output checkpoint value	2C7A	6C7A			×		×	O-F		
	F02	Mathematical/logical operations	2C83	6C83					-		
		Setting 1	2C84	6C84					O-F02		
		Setting 2	2C85	6C85					O-F02		
		Setting 3	2C86	6C86					O-F02		
		Contact input	2C87	6C87					-		
		Contact input monitor	2C88	6C88			×		×		-
		Contact output monitor	2C89	6C89			×		×		-
	Operation unit output checkpoint value	2C8A	6C8A			×		×	O-F		
	F03	Mathematical/logical operations	2C93	6C93					-		
		Setting 1	2C94	6C94					O-F03		
		Setting 2	2C95	6C95					O-F03		
		Setting 3	2C96	6C96					O-F03		
		Contact input	2C97	6C97					-		
		Contact input monitor	2C98	6C98			×		×		-
		Contact output monitor	2C99	6C99			×		×		-
	Operation unit output checkpoint value	2C9A	6C9A			×		×	O-F		
	F04	Mathematical/logical operations	2CA3	6CA3					-		
		Setting 1	2CA4	6CA4					O-F04		
		Setting 2	2CA5	6CA5					O-F04		
		Setting 3	2CA6	6CA6					O-F04		
		Contact input	2CA7	6CA7					-		
		Contact input monitor	2CA8	6CA8			×		×		-
		Contact output monitor	2CA9	6CA9			×		×		-
	Operation unit output checkpoint value	2CAA	6CAA			×		×	O-F		
	F05	Mathematical/logical operations	2CB3	6CB3					-		
		Setting 1	2CB4	6CB4					O-F05		
		Setting 2	2CB5	6CB5					O-F05		
		Setting 3	2CB6	6CB6					O-F05		
		Contact input	2CB7	6CB7					-		
		Contact input monitor	2CB8	6CB8			×		×		-
		Contact output monitor	2CB9	6CB9			×		×		-
	Operation unit output checkpoint value	2CBA	6CBA			×		×	O-F		
	F06	Mathematical/logical operations	2CC3	6CC3					-		
		Setting 1	2CC4	6CC4					O-F06		
		Setting 2	2CC5	6CC5					O-F06		
		Setting 3	2CC6	6CC6					O-F06		
		Contact input	2CC7	6CC7					-		
Contact input monitor		2CC8	6CC8			×		×	-		
Contact output monitor		2CC9	6CC9			×		×	-		
Operation unit output checkpoint value	2CCA	6CCA			×		×	O-F			

Chapter 6. LIST OF SETTING DATA AND COMMUNICATION DATA

Bank name	No.	Item name	RAM address	EEPROM address	RAM		EEPROM		Decimal point information	Remarks
			Hexadecimal	Hexadecimal	Read	Write	Read	Write		
Output operation	F07	Mathematical/logical operations	2CD3	6CD3					-	Cannot be read/written on the SDC45A/46A.
		Setting 1	2CD4	6CD4					O-F07	
		Setting 2	2CD5	6CD5					O-F07	
		Setting 3	2CD6	6CD6					O-F07	
		Contact input	2CD7	6CD7					-	
		Contact input monitor	2CD8	6CD8		×		×	-	
		Contact output monitor	2CD9	6CD9		×		×	-	
		Operation unit output checkpoint value	2CDA	6CDA		×		×	O-F	
	F08	Mathematical/logical operations	2CE3	6CE3					-	
		Setting 1	2CE4	6CE4					O-F08	
		Setting 2	2CE5	6CE5					O-F08	
		Setting 3	2CE6	6CE6					O-F08	
		Contact input	2CE7	6CE7					-	
		Contact input monitor	2CE8	6CE8		×		×	-	
		Contact output monitor	2CE9	6CE9		×		×	-	
		Operation unit output checkpoint value	2CEA	6CEA		×		×	O-F	
	F09	Mathematical/logical operations	2CF3	6CF3					-	
		Setting 1	2CF4	6CF4					O-F09	
		Setting 2	2CF5	6CF5					O-F09	
		Setting 3	2CF6	6CF6					O-F09	
		Contact input	2CF7	6CF7					-	
		Contact input monitor	2CF8	6CF8		×		×	-	
		Contact output monitor	2CF9	6CF9		×		×	-	
		Operation unit output checkpoint value	2CFA	6CFA		×		×	O-F	
	F10	Mathematical/logical operations	2D03	6D03					-	
		Setting 1	2D04	6D04					O-F10	
		Setting 2	2D05	6D05					O-F10	
		Setting 3	2D06	6D06					O-F10	
Contact input		2D07	6D07					-		
Contact input monitor		2D08	6D08		×		×	-		
Contact output monitor		2D09	6D09		×		×	-		
Operation unit output checkpoint value		2D0A	6D0A		×		×	O-F		

6 - 6 Standard Bit Codes and Standard Numerical Codes

Standard bit codes

The range of the standard bit codes is 1024 to 2047.

Codes not stated in the list are undefined. Therefore, do not use such codes

The standard bit codes are set values common to the following items:

- Output type (出力) of output bank (ON/OFF output)
- Input type (入力) of internal contact input bank
- Output type (出力, 出力) of digital output (C/E-column terminal)
- Input assignment A/B/C/D (BF-02 to BF-05) of logical operation
- Lighting conditions (点灯) for display and key bank (MS display)
- Lighting conditions (点灯) for display and key bank (UFLED setting)
- Tracking selection (追従) of MV bank
- MV tracking selection (追従) of MV bank

Standard bit code	Meaning of standard bit
1024	OFF (0)
1025	ON (1)
1088	Event 1
1089	Event 2
1090	Event 3
1091	Event 4
1092	Event 5
1093	Event 6
1094	Event 7
1095	Event 8
1096	Event 9
1097	Event 10
1098	Event 11
1099	Event 12
1100	Event 13
1101	Event 14
1102	Event 15
1103	Event 16
1120	CT1 Heater burnout detection
1121	CT2 Heater burnout detection
1124	CT1 Over-current detection
1125	CT2 Over-current detection
1128	CT1 Short-circuit detection
1129	CT2 Short-circuit detection
1152	Terminal status of DI-C1
1153	Terminal status of DI-C2
1154	Terminal status of DI-C3
1155	Terminal status of DI-C4
1156	Terminal status of DI-C5
1157	Terminal status of DI-C6
1158	Terminal status of DI-C7
1159	Terminal status of DI-C8
1160	Terminal status of DI-D1
1161	Terminal status of DI-D2
1162	Terminal status of DI-D3
1163	Terminal status of DI-D4
1164	Terminal status of DI-D5
1165	Terminal status of DI-D6
1166	Terminal status of DI-D7
1167	Terminal status of DI-D8
1176	Terminal status of DI-F1
1177	Terminal status of DI-F2
1216	Terminal status of DO-C1
1217	Terminal status of DO-C2
1218	Terminal status of DO-C3
1219	Terminal status of DO-C4
1220	Terminal status of DO-C5

Standard bit code	Meaning of standard bit
1221	Terminal status of DO-C6
1222	Terminal status of DO-C7
1223	Terminal status of DO-C8
1232	Terminal status of DO-E1
1233	Terminal status of DO-E2
1234	Terminal status of DO-E3
1235	Terminal status of DO-E4
1236	Terminal status of DO-E5
1237	Terminal status of DO-E6
1238	Terminal status of DO-E7
1239	Terminal status of DO-E8
1280	OUT1 (ON/OFF status)
1281	OUT2 (ON/OFF status)
1282	OUT3 (ON/OFF status)
1283	OUT4 (ON/OFF status)
1284	OUT5 (ON/OFF status)
1285	OUT6 (ON/OFF status)
1286	OUT7 (ON/OFF status)
1408	User defined bit 1
1409	User defined bit 2
1410	User defined bit 3
1411	User defined bit 4
1412	User defined bit 5
1413	User defined bit 6
1414	User defined bit 7
1415	User defined bit 8
1440	Results of logical operation 1
1441	Results of logical operation 2
1442	Results of logical operation 3
1443	Results of logical operation 4
1444	Results of logical operation 5
1445	Results of logical operation 6
1446	Results of logical operation 7
1447	Results of logical operation 8
1448	Results of logical operation 9
1449	Results of logical operation 10
1450	Results of logical operation 11
1451	Results of logical operation 12
1452	Results of logical operation 13
1453	Results of logical operation 14
1454	Results of logical operation 15
1455	Results of logical operation 16
1504	Key status (auto/man)
1505	Key status (sp/ev)
1506	Key status (para)
1507	Key status (rsp/lsp)
1508	Key status (at)

Standard bit code	Meaning of standard bit
1509	Key status (f1)
1510	Key status (f2)
1511	Key status (up)
1512	Key status (left)
1513	Key status (right)
1514	Key status (down)
1515	Key status (display)
1516	Key status (enter)
1545	Communication status (Normal receipt on a byte basis)
1547	Communication status (Normal transmission on a byte basis)
1548	Communication status (An error received)
1549	Power failure detection
1550	Hot start detection for loop 1 PID (Only SDC45V46V)
1551	Hot start detection for loop 2 PID (Only SDC45V46V)
1568	RUN/READY status of loop 1
1569	RUN/READY status of loop 2
1584	AUTO/MANUAL status of loop 1
1585	AUTO/MANUAL status of loop 2
1600	AT stop /AT status of loop 1
1601	AT stop /AT status of loop 2
1616	LSP/RSP status of loop 1
1617	LSP/RSP status of loop 2
1648	During SP ramp of loop 1 (ramp-up)
1649	During SP ramp of loop 2 (ramp-up)
1664	During SP ramp of loop 1 (ramp-down)
1665	During SP ramp of loop 2 (ramp-down)
1696	Backup/through output status of loop 1
1792	All typical alarms (logical OR of all alarms to be displayed)
1824	PV input high limit alarm (PV1)
1825	PV input high limit alarm (PV2/PV21)
1826	PV input high limit alarm (PV22)
1840	PV input low limit alarm (PV1)
1841	PV input low limit alarm (PV2/PV21)
1842	PV input low limit alarm (PV2/2)
1856	CJ input alarm (PV1)
1857	CJ input alarm (PV2)
1952	CT1 input alarm
1953	CT2 input alarm
1968	Parameter failure
1969	Adjustment value failure (CPU board)
1970	Adjustment value failure (PV board)
1972	ROM failure (CPU board)
1973	ROM failure (PV board)
1975	Battery voltage alarm (Only SDC45V46V)
1976	RTC alarm (Only SDC45V46V)

■ Standard numerical codes

The range of the standard numerical codes is 2048 to 3071.

Codes not stated in the list are undefined. Therefore, do not use such codes.

The standard numerical codes are set values common to the following items:

- Output type (20-22) of output bank (continuous output)
- Lighting status (25-22) of display and key bank (MS display)

Standard numerical code	Meaning of standard bit
2304	PV1
2305	PV2/PV21
2306	PV22 (3 inputs model only)
2320	PV of loop 1 (used for PID control)
2321	PV of loop 2 (used for PID control)
2336	SP of loop 1 (in use)
2337	SP of loop 2 (in use)
2352	SP of loop 1 (finally attained value)
2353	SP of loop 2 (finally attained value)
2384	SP output of loop 1
2416	MV of loop 1
2417	MV of loop 2
2432	Heat MV of loop 1
2433	Heat MV of loop 2
2448	Cool MV of loop 1
2449	Cool MV of loop 2
2464	MFB1 (Motor opening feedback value 1) (including estimation)
2480	MFB1 (Motor opening feedback value 1) (measurement value)
2496	CT1 current when output ON
2497	CT2 current when output ON
2512	CT1 current when output OFF
2513	CT2 current when output OFF
2528	Deviation of loop 1 (PV-SP)
2529	Deviation of loop 2 (PV-SP)
2592	Flow rate (temperature-pressure correction)
2608	Input computation result
2624	Output computation result
2656	Event 1 delay remaining time
2657	Event 2 delay remaining time
2658	Event 3 delay remaining time
2659	Event 4 delay remaining time
2660	Event 5 delay remaining time
2661	Event 6 delay remaining time
2662	Event 7 delay remaining time
2663	Event 8 delay remaining time
2664	Event 9 delay remaining time
2665	Event 10 delay remaining time
2666	Event 11 delay remaining time
2667	Event 12 delay remaining time
2668	Event 13 delay remaining time
2669	Event 14 delay remaining time
2670	Event 15 delay remaining time
2671	Event 16 delay remaining time
2720	MV used for position propotional control

azbil

Yamatake Corporation
Advanced Automation Company

1-12-2 Kawana, Fujisawa
Kanagawa 251-8522 Japan

URL: <http://www.azbil.com>

Specifications are subject to change without notice. (08)

1st Edition: Issued in May 2008 (W)