

DigitroniK™ Programmable Controller DCP31

The DigitroniK DCP31 is a high-function programmable controller supporting up to 19 program patterns to which thermocouple signals, resistance temperature detector (RTD) signals, DC voltages and DC currents can be input.

The DCP31 supports extensive digital I/O functions including 3 event outputs, 5 time events (optional) and 12 external switch inputs (8 optional). RS-485 communications and two auxiliary outputs can also be added on as options.

■ Features

- Accuracy of $\pm 0.1\%$ FS. Highly accurate and high-speed sampling cycle of 0.1 s
- Any input type can be selected by console key operation.
- A maximum of 19 program patterns can be stored and up to 30 segments can be programmed to each pattern.
- Programs can be loaded to the controller by a personal computer loader, eliminating troublesome console operation.
- Provided with 3 event outputs for notifying PV, deviation, controller mode or other states.
- 12 external switch inputs (8 optional) allow remote selection of program Nos. or operation.
- Up to eight frequently changed parameter setups can be registered to the PARA key.
- Supports any power supply within range 90 to 264 Vac.



- Wide range of optional functions enables use in an extensive range of applications.
 - ★ 5 time event outputs
 - ★ 8 external switch inputs
 - ★ Maximum 2 auxiliary outputs (1 only on 2G and heat-cool models)
 - ★ Communications function (RS-485)

■ Basic Function Blocks of DCP31

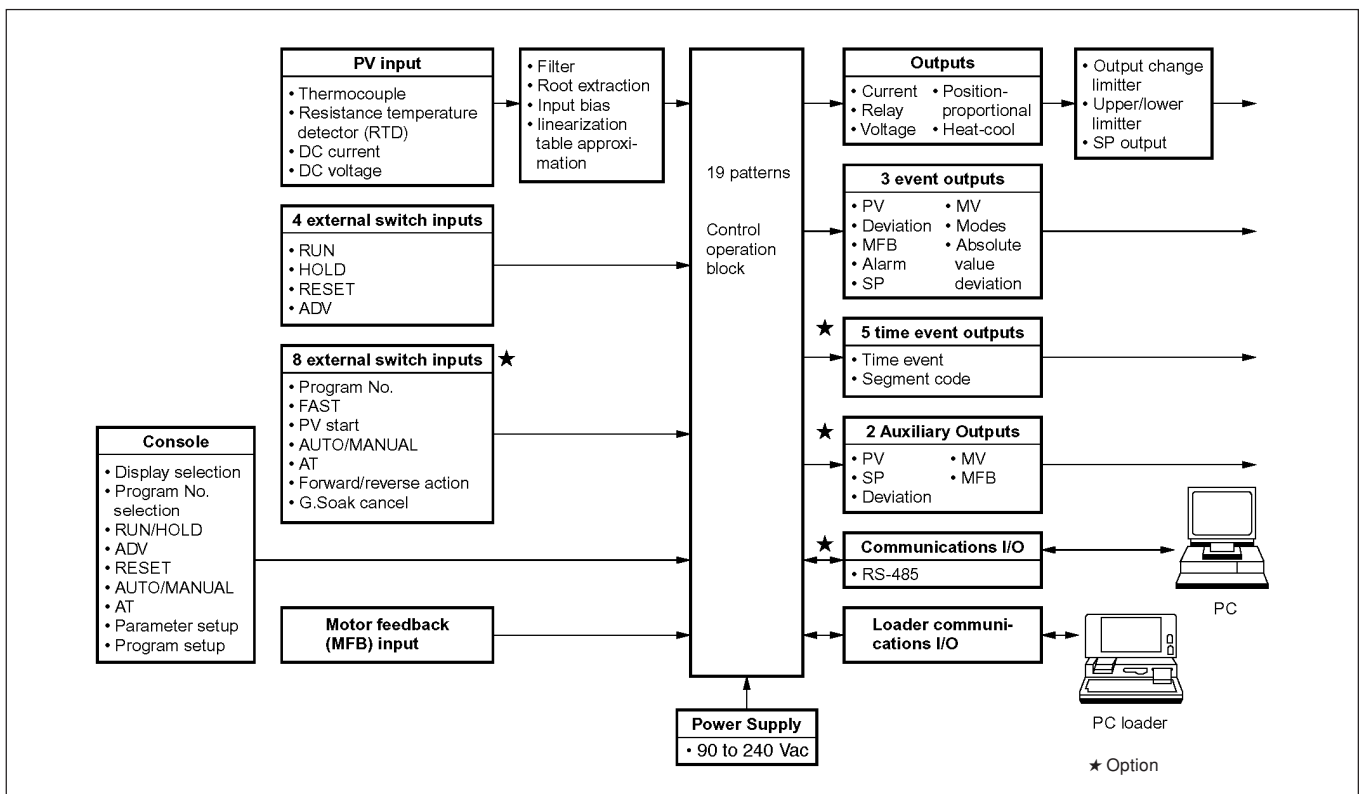

■ Specifications

Program	Number of programs	19	
	Number of segments	30 per program	
	Segment setting system	RAMP-X system: Set by set points (SP) and time.	
	Segment time	0 to 99 h 59 min, or 0 to 99 min 59 s (time unit selectable)	
	Events (3)	Set operating point.	
	Time events (5)	Set ON and OFF times.	
	PID set No.	Set 0 to 8. (Set 0 for continuation of previous segment.) (Set 0 to 4 on heat/cool models.)	
	G.Soak width	0 to 1000U.	
	PV start	Sets program ON/OFF.	
	Cycle	Sets program count 0 to 9999.	
	Pattern link	Sets program No.0 to 19 (0: no link)	
	Tag	Sets 8 alphanumeric for each program. (not displayed on controller)	
PV inputs	Number of input channels	1	
	Input type	Thermocouple, resistance temperature detector, DC voltage, DC current multi-range (See Table 1.)	
	Input readout accuracy	$\pm 0.1\%$ FS ± 1 U (varies according to standard conditions, display value conversion and range)	
	Sampling cycle	0.1 s	
	Digital filter	0.0 to 120.0 s variable (0.0: filter OFF)	
	Square root extraction	Possible. Dropout: 0.1 to 10.0% FS variable (in case of DC current or voltage input)	
	Input bias	-1000 to +1000U variable	Note 1: U: Unit (indication unit) Example: When the range is 0.0 to 300.0°C, 1U = 0.1°C, 100U = 10.0°C
	Scaling	-1999 to +9999U (possible in case of DC current or voltage input, inverse scaling possible, decimal point position/any setting possible)	
	Input impedance	DC current input: 50 Ω $\pm 10\%$ (under operating conditions)	
	Input bias current	Thermocouple, DC voltage input: Max. ± 1.3 μ A (at peak value, reference conditions) 1 V or higher range: Max. -3 μ A	
Measuring current	RTD input: 1.04 mA ± 0.02 mA, current flow from terminal A (under operating conditions)		
Influence of wiring resistance	DC voltage input: Changes in readout value at wiring resistance of 250 Ω at both ends are as follows by input conversion: • 0 to 10 mV, -10 to +10 mV: Within 35 μ V • 0 to 100 mV: Within 60 μ V • Other: Within 750 μ V	Thermocouple Changes in readout value at wiring resistance of 250 Ω at both ends are as follows by input conversion: • E08, Z13, Z07: Within 60 μ V • Other: Within 35 μ V	
	RTD input: Max. $\pm 0.01\%$ FS in wiring resistance range 0 to 10 Ω Range of F38, F33, F01, P38, P33 and P01: $\pm 0.02\%$ FS/ Ω max. Allowable wiring resistance is 85 Ω max. (including Zener barrier resistance). (When a Zener barrier is used, this applies only to ranges other than F38, F33, F01, P38, P33 and P01. Note that site adjustment is required.)		

PV inputs	Allowable parallel resistance	Thermocouple disconnection detection allowable parallel resistance: 1 MΩ min.		
	Max. allowable input	Thermocouple, DC voltage input: –5 to +15 Vdc DC current input: 50 mA DC, 2.5 Vdc		
	Burnout	Upscale/downscale internally selectable by programmer.		
	Over-range detection threshold	110%FS min.: Upscaled –10%FS max.: Downscaled (Note that F50 range is not downscaled. Lower readout limit of B18 range is 20°C, 68°F.)		
	Cold-junction compensation accuracy	±0.5°C (under standard conditions)		
	Cold-junction compensation system	Internal/external (0°C only) compensation selectable		
	linearization table approximation	12 (both ends fixed. 11 intermediate points variable)		
Indication/ programmer	Upper display	Green 4-digit, 7-segment LED This displays PV values in the basic display state. Item codes are displayed in parameter setup.		
	Lower display	Orange 4-digit, 7-segment LED This displays SP and output% in the basic display state. Setting values are displayed in parameter setup.		
	Program No. display	Green 2-digit, 7-segment LED This displays the program No. in the basic display state.		
	Segment No. display	Green 2-digit, 7-segment LED This displays the segment No. in the basic display state. Item Nos. are displayed in parameter setup, and alarm No. is displayed when alarm occurs.		
	Profile display	6 orange LEDs Displays program pattern rise, soak and fall tendencies.		
	Status displays	22 round LEDs Modes: RUN, HLD, MAN, PRG (green) Display details: PV, SP, OUT, TM, CYC (green) Battery voltage: BAT (red) (blinks at low voltage) Status: AT, OT1, OT2, OT3 (orange) Events: EV1, EV2, EV3, T1, T2, T3, T4, T5 (orange)		
	Operation keys	13 rubber keys		
	Loader connector port	1 (dedicated cable with stereo miniplugs)		
	Program operation modes	READY RUN HOLD FAST END	Ready to run program (control stop/program No. selectable) Program run Program hold Program fast-forward Program end	
		AUTO MANUAL	Automatic operation Manual operation (output controlled on console)	
	Constant-value operation modes	READY RUN	Ready to run program (control stop) Program run	
		AUTO MANUAL	Automatic operation Manual operation (output controlled on console)	

Indication/ programmer Controller	Control method	Program control or constant-value control selectable					
	Model Nos.	0D	2G	5G	6D	3D	5K
	Control mode	Time-proportional PID	Position-proportional PID	Continuous PID	Time-proportional PID	2-stage (heat-cool) PID	
	Output modes	1a1b relays Contact output	M/M drive relays Contact output	Current (4 to 20 mA dc) output	Voltage output	1a1b relay contact output + 1a1b relay contact output	Current output + current output (current → voltage output changeable)
	PID auto-tuning	Automatic setting of PID value by limit cycle system + Neuro & Fuzzy (2 degrees of freedom PID) and Smart systems				Auto-tuning not possible	
	Output rating	Contact rating: 5A (30 Vdc, resistive load) 5A (120 Vac, resistive load) 4A (240 Vdc, resistive load) Allowable contact voltage: 250 Vac, resistive load 125 Vdc, resistive load Max. switching power: 150 W, resistive load 960 VA, resistive load Life: 100,000 operations (resistive load at contact rating, frequency: 30 operations/minute) Min. switching voltage: 5 V Min. switching current: 100 mA Output resolution: 1/1000 Time-proportional cycle: 5 to 120 seconds	Contact rating: 2.5A (30 Vdc, L/R=0.7 ms) 4A (120 Vac, cosφ=0.4) 2A (240 Vac, cosφ=0.4) Allowable contact voltage: 125 Vdc, L/R=0.7 ms 250 Vac, cosφ=0.4 Max. switching power: 75 W (L/R=0.7 ms) 480 VA (cosφ=0.4) Life: 100,000 operations (cosφ=0.4 at contact rating, frequency: 30 operations/minute) Min. switching voltage: 5 V Min. switching current: 100 mA MFB (motor feedback) input range: 100 to 2500 Ω Control at MFB (motor feedback) disconnection: ON/OFF for continuation of operation according to MFB estimated position can be selected.	Allowable load resistance: 680 Ω max. (under operating conditions) Output accuracy: ±0.1% FS max. (under operating conditions) Output resolution: 1/10000 Inrush current: 25 mA max. for 50 ms max. (at 250 Ω load) Max. output current: 21.6 mA dc Min. output current: 2.4 mA dc Output updating cycle: 0.1 seconds	Allowable load resistance: 680 Ω max. (under operating conditions) Inrush current: 25 mA max. for 50 ms max. (at 250 Ω load) Load current adjustment: 2 to 22 mA variable Open terminal voltage: 25 V max. OFF leakage current: 100 µA max. Output response time: At ON-OFF 680 Ω load: 0.5 ms max. At OFF-ON 680 Ω load: 1.0 ms max. Output resolution: 1/1000 Time-proportional cycle: 1 to 60 seconds variable	Contact rating: 5A (30 Vdc, resistive load) 5A (120 Vac, resistive load) 4A (240 Vdc, resistive load) Allowable contact voltage: 250 Vac, resistive load 125 Vdc, resistive load Max. switching power: 150 W, resistive load 960 VA, resistive load Life: 100,000 operations (resistive load at contact rating, frequency: 30 operations/minute) Min. switching voltage: 5 V Min. switching current: 100 mA Output resolution: 1/1000 Time-proportional cycle: 5 to 120 seconds	Allowable load resistance: 680 Ω max. (under operating conditions) Output accuracy: ±0.1% FS max. (under operating conditions) Output resolution: 1/10000 Inrush current: 25 mA max. for 50 ms max. (at 250 Ω load) Max. output current: 21.6 mA dc Min. output current: 2.4 mA dc Output updating cycle: 0.1 seconds
	Proportional band (P)	0.0 to 999.9% (0.0: ON-OFF control)	0.1 to 999.9%	0.1 to 999.9%	0.0 to 999.9% (0.0: ON-OFF control)	0.1 to 999.9%	0.1 to 999.9%
	Reset time (I)	0 to 3600 s (0: no reset action)					
	Rate time (D)	0 to 1200 s (0: no rate action)					
	Manual reset	0.0 to 100.0%					
	Number of PID sets	8 sets for program operation + 1 set for constant-value operation (in heat/cool control: 4 sets for program operation + 1 set for constant-value operation)					
PID set selection	Segment designation/automatic zone selection can be switched by program operation						

	Model Nos.	0D	2G	5G	6D	3D	5K	
Controller	ON-OFF control differential	0 to 1000U	—	—	0 to 1000U	—	—	
	Position-proportional dead zone	—	0.5 to 25.0%	—	—	—	—	
	Heat/cool dead zone	—	—	—	—	-100.0 to +50.0%	-100.0 to +50.0%	
	MV limit	Lower limit: -10.0 to upper limit %						
		Upper limit: Lower limit to 110.0%						
	MV change limit	0.0 to 10.0%/0.1 seconds (0.0: no limit)						
	Direct/reverse action switching	Switchable	Switchable	Switchable	Switchable	—	—	—
	3-position-deviation lower limit	—	—	—	—	0 to 1000U	—	—
	3-position-deviation upper limit	—	—	—	—	0 to 1000U	—	—
	3-position-deviation lower limit hysteresis	—	—	—	—	0 to 1000U	—	—
	3-position-deviation upper limit hysteresis	—	—	—	—	0 to 1000U	—	—
	Programmer function switching	—	—	MV output switchable to SP output	—	—	—	—
	Programmer function scaling	—	—	Possible	—	—	—	—
	Programmer function output resolution	—	—	1/10000	—	—	—	—
Events/time events	Number of outputs	Events: 3 Time events: 5						
	Event output types	PV type events: PV, deviation, absolute value deviation, SP, MV, MFB (motor feedback) Controller status events: RUN+HOLD+FAST+END, READY, RUN, HOLD, FAST, END, G.Soak standby, MANUAL, AT (auto-tuning) executing, constant-value operation, MFB estimated position control, sum of all alarms, PV range alarm, controller alarms, low battery voltage, console setup in progress, ADV						
	Time event output type	Time events, segment No. events						

Events/time events	Event output rating	Event outputs 1, 2	Contact type: 1a relay contact Electrical rating: 240 Vac, 30 Vdc, 1 A resistive load Life: 100,000 operations (at rating) Min. switching voltage: 10 V Min. switching current: 10 mA
		Event output 3	Contact type: 1a1b relay contact Electrical rating: 240 Vac, 30 Vdc, 2 A resistive load Life: 100,000 operations (at rating) Min. switching voltage: 10 V Min. switching current: 10 mA
	Time event output rating	Time events 1 to 5	Contact type: NPN transistor, open-collector External supply voltage: 10 to 29 Vdc Max. load current: 70 mA/load OFF-state leakage current: 0.1 mA ON-state voltage drop: 1.6 V max.
	Events 1 to 3 setting	Event standby	ON/OFF selectable
	Connectable format	Event hysteresis	0 to 200U (event output types PV, deviation, absolute value deviation or SP) 0.0 to 20.0% (event output types MV or MFB)
	Number of inputs	Event ON delay	0 to 3600 s
External switch inputs	Number of inputs	12	
	Types of connectable outputs	Dry contacts (relay contact) and open-collector (current sink to ground)	
	Terminal voltage (open)	10.4 V to 12.6 V between common terminal (terminal (25)) and each input terminal (under operating conditions)	
	Terminal current (short-circuit)	5.0 to 6.6 mA between each terminal (under operating conditions)	
	Allowable contact resistance (dry contact)	ON: 700 Ω max. (under operating conditions) OFF: 10 k Ω min. (under operating conditions)	
	Voltage drop (at open-collector ON)	3 V max. (under operating conditions)	
	Leakage current (at open-collector OFF)	0.1 mA max. (under operating conditions)	
	Assignments (fixed)	RUN, HOLD, RESET, ADV, program No.	
	Assignments (variable)	FAST, PV start, AT, AUTO/MANUAL, G.Soak cancel, reverse/forward action	
	Input sampling cycle	0.1 s	
ON detection min. hold time	0.2 s (program No. 0.4 s)		

Auxiliary outputs	Number of outputs	Max. 2 (1 on 2G and heat/cool models)	
	Output types	PV, SP, deviation, MV, MFB (motor feedback)	
	Output rating	4 to 20 mA dc, Allowable load resistance: 680 Ω max.	
	Output accuracy	±0.1%FS max. (under standard conditions)	
	Output updating cycle	0.1 seconds	
	Output resolution	1/10000 (not including input resolutions of PV or MFB)	
	Inrush current	25 mA max. for 50 ms max. (at 250 Ω load)	
	Max. output current	21.6 mA	
	Min. output current	2.4 mA	
	Open terminal voltage	15 V max.	
Communi- cations	Communica- tions system	Communica- tions standard	RS-485
		Network	Multidrop (DCP31 provided with only slave node functionality) 1 (host) to 16 (slave) units max. when DIM is set as host station 1 (host) to 31 (slave) units max. when CMA, SCM are set as host stations
		Data flow	Half duplex
		Synchroniza- tion	Start-stop synchronization
	Interface system	Transmission system	Balanced (differential)
		Data line	Bit serial
		Signal line	5 transmit/receive lines (3-wire connection also possible)
		Transmission speed	4800, 9600 bps
		Transmission distance	500 m max. (total) (300 m max. for Yamatake Corporation MA500 DIM connection)
		Other	Conforming to RS-485
	Display characters	Char. bit count	11 bits/characte
		Format	1 start bit, even parity, 1 stop bit; or 1 start bit, no parity, and 2 stop bits
		Data length	8 bits
	Isolation	All inputs and outputs are completely isolated.	
	RS-485 communications can be performed by connecting to a computer equipped with an RS-485 interface or to Yamatake Corporation MX200, MA500 (DK link II DIM) or CMA50 controllers.		
General specifica- tions	Memory backup	Data held in RAM by lithium battery. Battery life Controller power OFF: Approx. 3 years under standard conditions Controller power ON: Approx. 10 years under standard conditions	
	Rated power voltage	90 to 264 Vac, 50/60 Hz	
	Power consumption	25 VA max.	
	Power ON rush current	15 A max., 10 ms (under operating conditions)	
	Power ON operation	Reset time: 15 s max. (time until normal oepration possible under normal operating conditions)	

General specifications	Allowable transient power loss	20 ms max. (under operating conditions)				
	Insulation resistance	Min. 20 MΩ across power terminal ① or ② and GND terminal ③ (using a 500 Vac megger)				
	Dielectric strength	1500 Vac 50/60 Hz for 1 minute between power terminal and GND terminal 1500 Vac 50/60 Hz for 1 minute between relay output and GND terminal 500 Vac 50/60 Hz for 1 minute between non-power terminal and GND terminal 500 Vac 50/60 Hz for 1 minute between isolated terminals				
	Standard conditions	Ambient temperature	23 ±2°C			
		Ambient humidity	60 ±5% RH			
		Rated power voltage	105 Vac ±1%			
		Power frequency	50 ±1 Hz or 60 ±1 Hz			
		Vibration resistance	0 m/s ²			
		Shock resistance	0 m/s ²			
		Mounting angle	Reference plane (vertical) ±3°			
	Operating conditions	Ambient temperature range	0 to 50 °C			
		Ambient humidity range	10 to 90% RH (no condensation)			
		Rated power voltage	90 to 264 Vac			
		Power frequency	50 ±2 Hz or 60 ±2 Hz			
		Vibration resistance	0 to 1.96 m/s ²			
		Shock resistance	0 to 9.81 m/s ²			
		Mounting angle	Reference plane (vertical) ±10°			
	Transport/storage conditions	Ambient temperature range	-20 to +70°C			
		Ambient humidity range	10 to 95% RH (no condensation)			
		Vibration resistance	0 to 4.90 m/s ² (10 to 60 Hz for 2 h each in X, Y and Z directions)			
Shock resistance		0 to 490 m/s ² (3 times vertically)				
Package drop test		Drop height: 90 cm (1 angle, 3 edges and 6 planes; free fall)				
Mask/case materials	Mask: Multilon / Case: Polycarbonate					
Mask/case color	Mask: Dark gray / Case: Light gray					
Installation	Specially designed mounting bracket					
Weight	Approx. 900 g					
Standard accessories	Item	Model No.	Q'ty	Options	Item	Model No.
	Unit indicating label	N-3132	1		Hard dust-proof cover set	81446083-001
	Mounting bracket	81405411-001	1 set (2 units)		Soft dust-proof cover set	81446087-001
	User's Manual	CP-UM-1757	1		Terminal cover set	81446084-001
					Lithium battery set	81446431-001

Table 1. Input Types and Ranges (selectable in setup)

Type	Input Type	Range No.	Code	Temp. Range (°C)	Temp. Range (°F)
Thermo-couple	K (CA)	0	K09	0 to 1200	0 to 2400
	K (CA)	1	K08	0.0 to 800.0	0 to 1600
	K (CA)	2	K04	0.0 to 400.0	0 to 750
	K (CA)	3	K29	-200 to +1200	-300 to +1200
	K (CA)	4	K44	-200.0 to +300.0	-300 to +700
	K (CA)	5	K46	-200.0 to +200.0	-300 to +400
	E (CRC)	6	E08	0.0 to 800.0	0 to 1800
	J (IC)	7	J08	0.0 to 800.0	0 to 1600
	T (CC)	8	T44	-200.0 to +300.0	-300 to +700
	B (PR30-6)	9	B18	0 to 1800	0 to 3300
	R (PR13)	10	R16	0 to 1600	0 to 3100
	S (PR10)	11	S16	0 to 1600	0 to 3100
	W (WRe5-26)	12	W23	0 to 2300	0 to 4200
	W (WRe5-26)	13	W14	0 to 1400	0 to 2552
	PR40-20	14	D19	0 to 1900	0 to 3400
	Ni-Ni-M0	15	Z13	0 to 1300	32 to 2372
	N	16	U13	0 to 1300	32 to 2372
	PL II	17	Y13	0 to 1300	32 to 2372
	DIN U	18	Z08	-200.0 to +400.0	-300 to +750
	DIN L	19	Z07	-200.0 to +800.0	-300 to +1600
Golden-iron-chromel	20	Z06	0.0 to 300.0K	—	
Resistance temperature detector (RTD)	JIS'89 Pt100 (IEC Pt100 Ω)	32	F50	-200.0 to +500.0	-300 to +900
		33	F46	-200.0 to +200.0	-300 to +400
		34	F32	-100.0 to +150.0	-150.0 to +300.0
		35	F36	-50.0 to +200.0	-50.0 to +400.0
		36	F38	-60.0 to +40.0	-76.0 to +104.0
		37	F33	-40.0 to +60.0	-40.0 to +140.0
		38	F05	0.0 to 500.0	0.0 to 900.0
		39	F03	0.0 to 300.0	0.0 to 500.0
	JIS'89 Pt100	40	F01	0.00 to 100.00	0.0 to 200.0
		48	P50	-200.0 to +500.0	-300 to +900
		49	P46	-200.0 to +200.0	-300 to +400
		50	P32	-100.0 to +150.0	-150.0 to +300.0
		51	P36	-50.0 to +200.0	-50.0 to +400.0
		52	P38	-60.0 to +40.0	-76.0 to +104.0
		53	P33	-40.0 to +60.0	-40.0 to +140.0
		54	P05	0.0 to 500.0	0.0 to 900.0
55	P03	0.0 to 300.0	0.0 to 500.0		
56	P01	0.00 to 100.00	0.0 to 200.0		

- Readout Accuracy (items out-side of ±0.1% FS range)
 - At -100°C max. of K and T thermocouples: ±1°C1U
 - At 260°C max. of B thermocouple: ±4% FS±1U
 - At 260 to 800°C: ±0.4% FS±1U
 - At 800 to 1800°C: ±0.2% FS±1U
 - At 100°C max. of R and S thermocouples: ±0.2% FS±1U
 - At 100 to 1600°C: ±0.15% FS±1U
 - At 300°C max. of PR40-20 thermocouple: ±2.5% FS±1U
 - At 300 to 800°C: ±1.5% FS±1U
 - At 800 to 1900°C: ±0.5% FS±1U
 - Golden iron chromel thermocouple: ±1.5K±1U
 - 2-digit range past decimal point by RTD input: ±0.15%±1U
 - At 0 to 10 mV range: ±0.15% FS±1U
 - At -100°C max. of DIN U thermocouple: ±2°C±1U
 - At -100 to 0°C: ±1°C±1U
 - At -100°C max. of DIN L thermocouple: ±1.5°C±1U
- The unit of code Z06 is Kelvin (K).
- The lower limit readout of code B18 is 20° C (68° F).
- The lower limit readout (°C) of codes K44, K46, T44, Z08 and Z07 is -199.9°C.
- The lower limit readout (°C) of codes F50, F46, P50 and P46 is -199.9°C.
- The upper limit readout (°C) of codes F01 and P01 is 99.99°C.
- The PV lower limit alarm does not occur with code F50.

■ Input Types

- Thermocouple: K,E,J,T,B,R,S (JIS C 1602-1981)
 WRe5-26 (Hoskins Data)
 PR40-20 (Johnson Matthey Data)
 N (N.B.S. Monograph 161)
 PLII (Engelhard Industries Data (IPTS68))
 Ni-NiMo (General Electric Data)
 DIN U (DIN43710-1985)
 DIN L (DIN43710-1985)
 Gold iron chromel (Hayashidenko Data)
- Resistance temperature detector (RTD):
 Pt100, JPt100 (JIS C 1604-1989)

Type	Input Type	Range No.	Code	Range (programmable)
DC current	4 to 20 mA	64	C01	-1999 to +9999
	0 to 20 mA	65	C08	
DC voltage	0 to 10 mV	66	M01	
	-10 to +10 mV	67	L02	
	0 to 100 mV	68	L01	
	0 to 1 V	69	L04	
	-1 to +1 V	70	L08	
	1 to 5 V	71	V01	
	0 to 5 V	72	L05	
	0 to 10 V	73	L07	

- The number of digits past the decimal point for DC current and DC voltage is programmable within the range 0 to 3.
- The readout accuracy of M01 is ±0.15% FS±1U.

■ Model Selection Guide

Example: P31A0D0AS0000

I	II	III	IV	V	VI	VII	Description
Basic Model No.	Output	Function	Power	Option 1	Option 2	Additions	
P31A							Digital Program Controller (single-loop model)
	0D						Relay outputs (on-off, or time-proportional)
	2G						Position-proportional output
	5G						Current output (4 to 20 mA) (controller/programmer selectable) (changeable to 6D output)
	6D						Voltage output (current value adjustment function supported, ON-OFF, or time-proportional) (changeable to 5G output)
	3D						Heat-cool output, relay output + relay output (PID control or 3-position-control)
	5K						Heat-cool output, current output + current output (current → voltage output changeable)
		0					One input channel
			AS				Power Supply (90 to 264 VAC)
			(Note)	00			No auxiliary output
				01			1 auxiliary output
				02			2 auxiliary outputs
					0		External switch inputs (4), time events not supported, communications not supported
					1		External switch inputs (12), 5 time events supported, communications not supported
					2		External switch inputs (12), 5 time events supported, RS-485 communications supported
						00	Additional treatment not supported
						T0	Tropical treatment
						K0	Antisulfide treatment
						D0	Inspection Certificate supplied
						B0	Heat treatment + Inspection Certificate provided
						L0	Antisulfide treatment + Inspection Certificate provided
						Y0	Traceability Certificate

NOTE: On 2G, 3D and 5K output models, 2 auxiliary outputs (option 1) cannot be designated.

■ Dimensions

Unit: mm

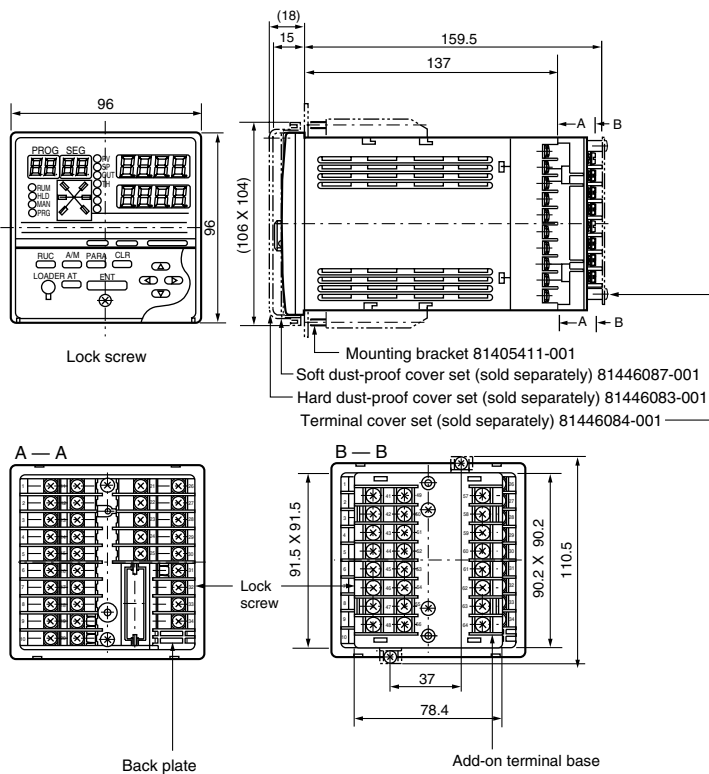

■ Panel Cutout

Unit: mm

Using the soft dust-proof cover

Using the hard dust-proof cover

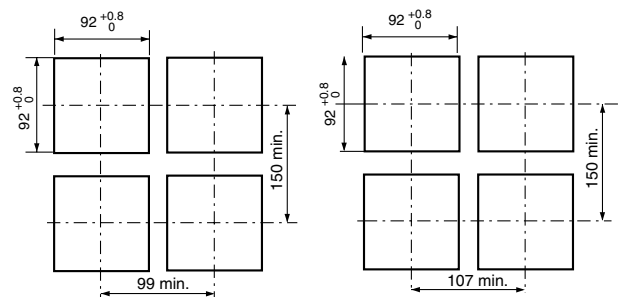

Close horizontal mounting

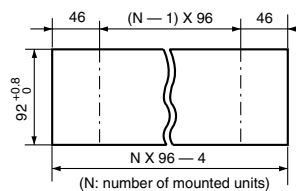

■ Wiring

• Standard terminal

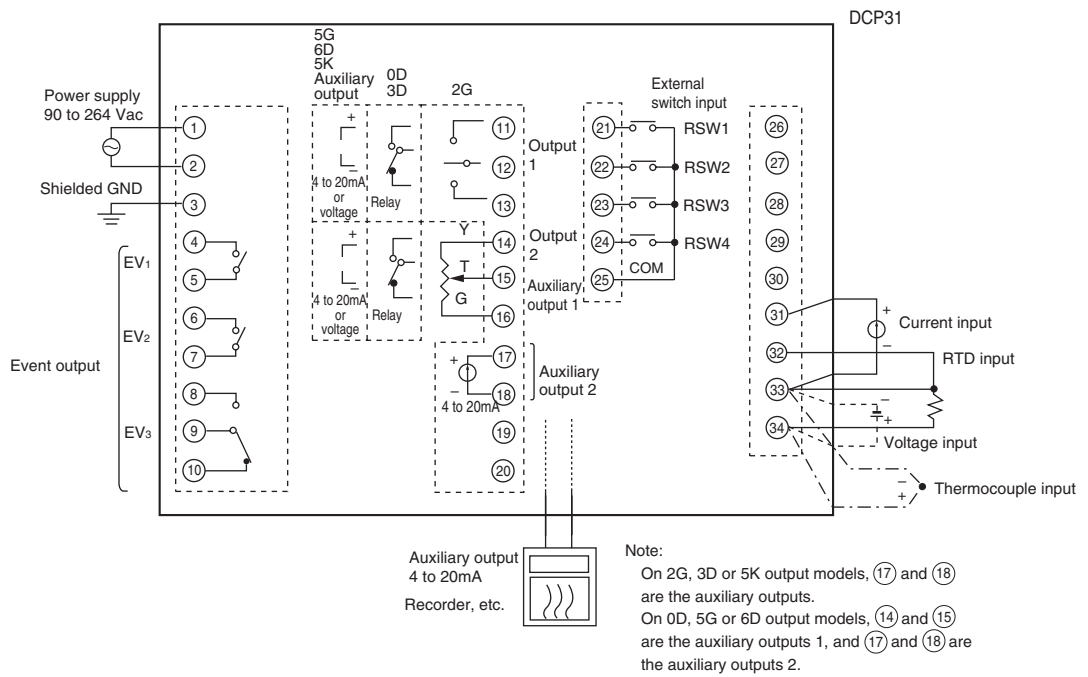

• Add-on terminal

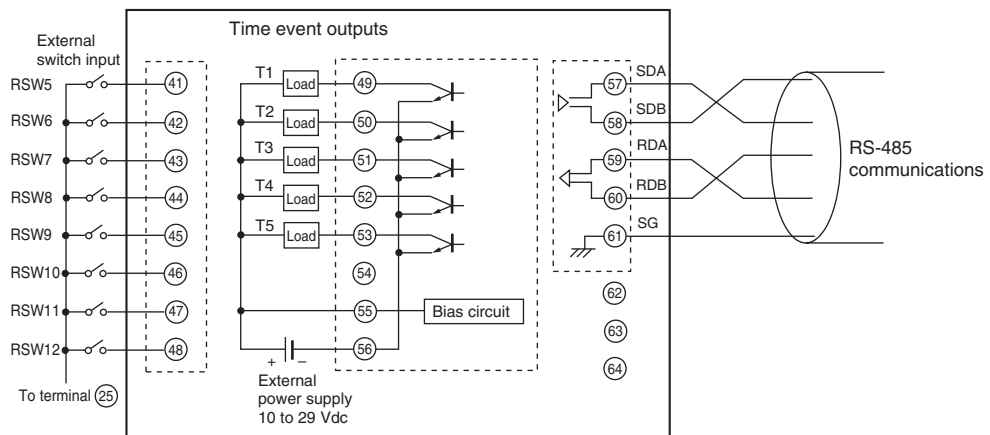

WIRING PRECAUTIONS

1. Isolating Inputs and Outputs inside the Controller

Solid lines — show isolated items.

Dotted lines show non-isolated items.

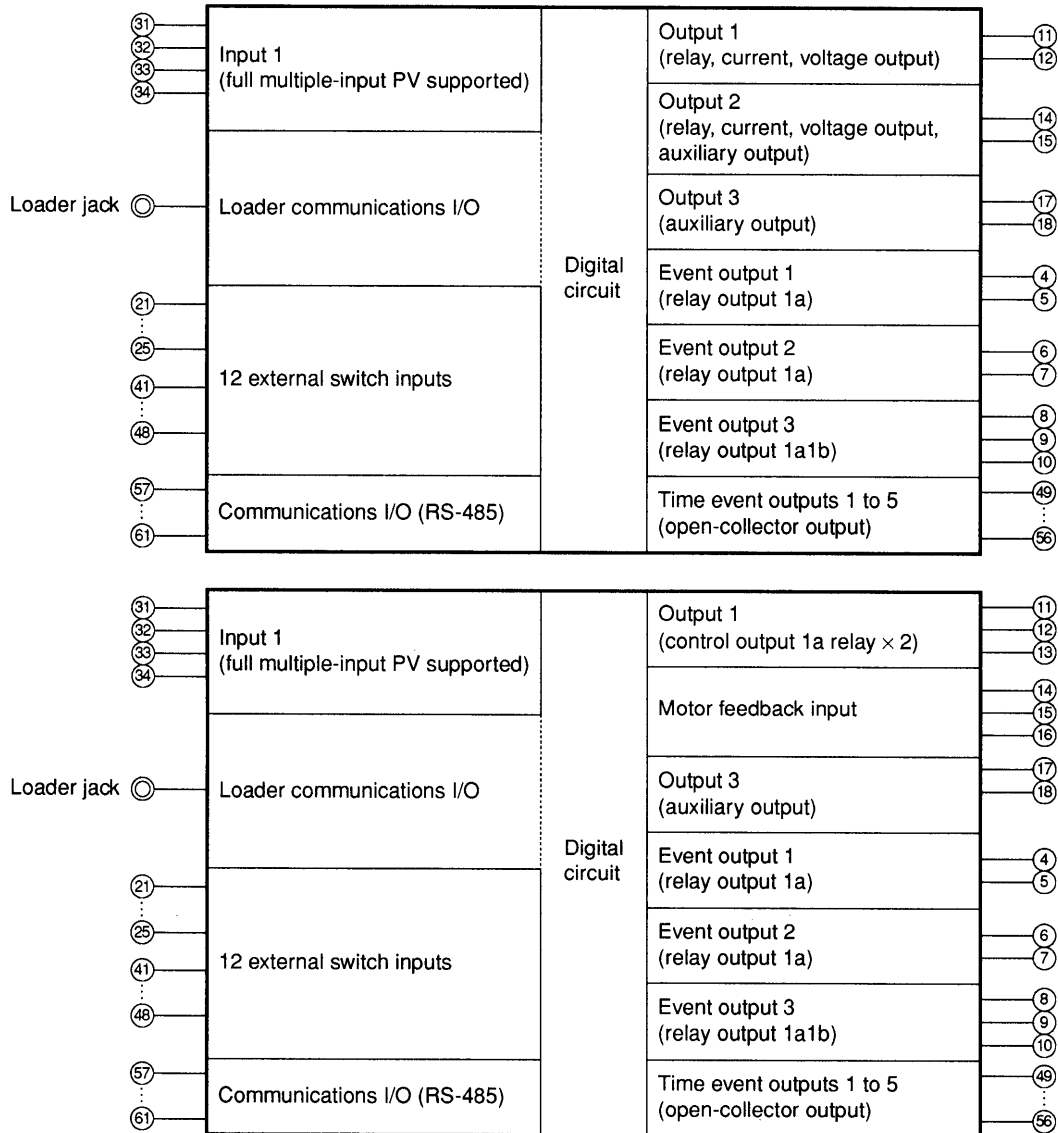

2. Noise Countermeasures for Instrument Power Supplies

(1) Reducing noise

Connect the DCP31 to a single-phase power supply for instruments, and use a line filter to prevent the influence of electrical noise.

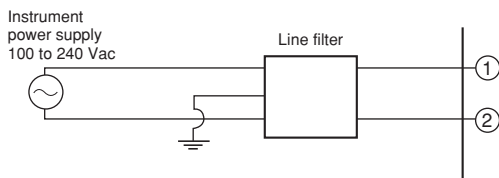

(2) When there is a lot of noise

If there is a lot of electrical noise, we recommend inserting an insulating transformer in the power circuit and using a line filter.

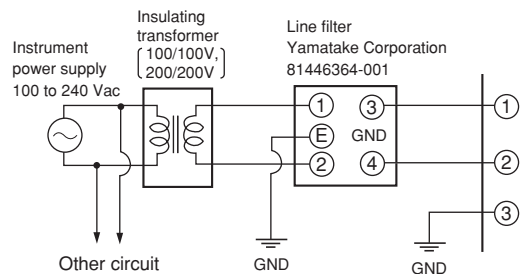

3. Noise Generating Sources and Countermeasures

Generally, the following generate electrical noise:

Relays and contacts, solenoid coils, solenoid valves, power lines (in particular, 90 VAC min.), induction loads, inverters, motor commutators, phase angle control SCR, wireless communications equipment, welding equipment, high-voltage ignition equipmen

(1) Fast-rising noise

CR filters are effective in countering fast-rising noise.

Recommended CR filter: Yamatake Corporation Model No.
81446365-001

(2) Noise with a high wave height

Varistors are effective in countering noise with a high wave height. However, note that the varistor may become short-circuited when trouble occurs. Pay attention to this when providing a varistor on a controller.

Recommended varister: Yamatake Corporation Model No.
81446366-001 (100 Vac)
81446367-001 (200 Vac)

4. Ground

Use only the GND terminal (3) on the DCP31 for grounding. Do not ground across other terminals. When it is difficult to ground shielded cable, prepare a separate GND terminal(earth bar).

Ground type: 100 Ω max.

Ground cable: 2 mm sq. min. soft-copper wire (AWG14)

Cable length: Max. 20 m

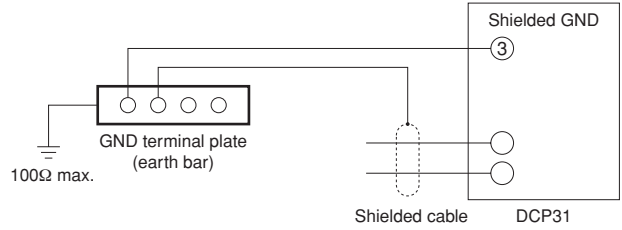

5. Precautions during Wiring

- (1) After providing anti-noise measures, do not bundle primary and secondary power leads together, or pass them through the same piping or wiring duct.
- (2) Maintain a distance of at least 50 cm between I/O signal leads or communications leads and the power lead. Also, do not pass these leads through the same piping or wiring duct.

6. Inspections after Wiring

After wiring is completed, be sure to inspect and check the wiring state. Wrong wiring may cause controller malfunction or accidents. When using this product in applications or important facilities requiring particular safety, special care should be taken to safely wire the controller and implement a fail-safe and/or redundant design, as well as a periodic maintenance program.

RESTRICTIONS ON USE

This product has been designed, developed and manufactured for general-purpose application in machinery and equipment. Accordingly, when used in the applications outlined below, special care should be taken to implement a fail-safe and/or redundant design concept as well as a periodic maintenance program.

- **Safety devices for plant worker protection**
- **Start/stop control devices for transportation and material handling machines**
- **Aeronautical/aerospace machines**
- **Control devices for nuclear reactors**

Never use this product in applications where human safety may be put at risk.

DIGITRONIK is a trademark of Yamatake Corporation.

Specifications are subject to change without notice.

azbil

Yamatake Corporation Advanced Automation Company

1-12-2 Kawana Fujisawa
Kanagawa 251-8522 Japan
URL:<http://www.azbil.com>

Printed in Japan. (H)
1st Edition: Issued in Sep., 1996
4th Edition: Issued in May, 2005

No part of this publication may be reproduced or duplicated without the prior written permission of Yamatake Corporation.

Printed on recycled paper.

(06)