

6/12/24 Dot Printing Model Smart Recorder SRF200

The Smart Recorder SRF 200 Dot Printing Model accepts DC voltage, thermocouple, resistance temperature detector (RTD), communications and ON/OFF inputs. This 6/12/24 Dot Printing Model accommodates 180 mm wide charts.

Smart Recorder offers the dual features of functions and operator ease as a recorder for various equipment and instrumentation.

It also supports relay output, open collector output, external switch inputs, chart illumination lamp and communications as optional functions.

FEATURES

- Any combination of different inputs and recording scale can be set freely.
DC voltage, thermocouple, resistance temperature detector (RTD), communications, ON/OFF input
- Five recording formats are provided and can be freely selected:
Trend recording, trend + tabulation recording, trend + schedule demand recording, fixed-time recording, fixed-date recording
- Six measurement and calculation methods are provided and can be selected to each channel:
Measurement value (PV value), deviation value between channels, deviation value from fixed value, total calculation, F value calculation, relative humidity calculation
- Free power supply allows use anywhere:
100 to 240V ac, 50/60 Hz
- Compact design. Only 187 mm deep
- Wide range of printing functions:
 - Measurement value (PV value)
 - Channel No.
 - Tag (12 characters per channel)
 - Engineering unit (6 characters per channel)
 - Recording scale (2 types, upper/lower limit values)
 - Chart feed speed
 - Event status (details, time of occurrence/restoration)
 - Time marker - Date
 - Time (hours:minutes)
- Printing at the following start conditions is possible:
 - Date - Time (hours:minutes)
 - Recording format - Chart feed speed
 - Recorder ID No.
- Manual demand printing also is possible.
Printing is started by **DMD** key or external switch input, time (hours:minutes) and measurement values (PV values) are printed.
- When trend + schedule demand recording is selected as the recording format, the measurement value (PV value) of up to eight preset times can automatically be printed.

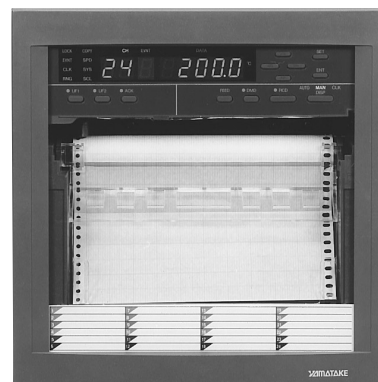

- Up to 24 digital inputs are supported: 12 external switch inputs coupled to remote switches, and 12 internal contact inputs that are connected to internal signals.
Output signals for up to 96 events (4 types x 24 channels) can be connected to any 12 internal contact inputs.
- Parameter setups can be assigned to user function keys. (up to eight types for each of the two switches)
- Printing of "Date/Time (hours:minutes)", "Scale" and "event" can be disabled.
- Seven list printing modes are available for printing setup data: partial list print, function list print (four modes), total list print and list print are available. Any list (85 characters x 3 lines) can be printed as a user setup list from a loader or by CPL communications.
- Upscale, downscale or OFF can be set as the thermocouple burnout setting for each input channel.
- Batch count (1 to 99) that is incremented and printed out at each start of recording can be set.
- Setup data is protected in EEPROM when the power is OFF.
- Copy setting:
Various setup data can be copied between channels.
- Segment table setup:
Output values (Y-axis) for input values (X-axis) can be offset by setting up segment tables.

OPTIONAL FUNCTIONS

- Relay output
(6/12 outputs; SPDT relay output)
- 12 open collector outputs
- External switch inputs
(4/8/12; Recording start/stop, Demand printing, List printing, Chart feed, Chart feed speed/Scale selection), Print messages No.1 to No.8, BIN code entry, Batch count clear, Total calculation reset, Recording mode selection
- Chart illumination lamp (cold-cathode discharge tube)
- Communications (RS-485, RS-232C)

SPECIFICATIONS

Input	Input type	DC voltage, thermocouple, resistance temperature detector (RTD), communications input, ON/OFF input See Table 1 (input type, range: indication accuracy). * In the case of DC current (4 to 20 mA), attach a converter resistor (sold separately, catalog No. 81446462-001 or 81401325), and convert to 1 to 5 V to input.	
	Number of input channels	6/12/24	
	Input measurement cycle	6/12 models: 15s, 24 model: 30s (fixed cycle regardless of number of measurement inputs)	
	Input impedance	DC voltage (± 2 V range max.), thermocouple input: 10 M Ω min.	
		DC voltage (± 5 V range min.) : 1 M Ω min.	
	Allowable wiring resistance	DC voltage, thermocouple input (input signal source resistor): 2 k Ω max.	
		RTD input (input wiring resistor) : 10 Ω max. (per line. However, resistance of three lines must be the same.)	
	Burnout	Thermocouple input: one of upscale/downscale OFF can be selected for each channel (burnout condition: 10 M Ω min.)	
	Input bias current	DC voltage (± 2 V range max.), thermocouple input: ± 100 nA max.	
		DC voltage (± 5 V range max.): ± 1 μ A max. However, current must be ± 200 nA max. when setting burnout for thermocouple input.	
	Measuring current	RTD input: Approx. 1 mA	
	Permissible input voltage range	Outside RTD range: -7 to +11V dc	
		RTD range: -5 to +5V dc	
	PV bias	Can be set to each channel in range -19999 to 29999 (engineering unit including decimal point).	
	Linear scaling	Display and recording is possible at actual unit (engineering unit) at linear scaling range DC voltage (range codes 00 to 06).	
	Direct-reading range	mV or V values can be read directly with linear scaling set to OFF during input voltage direct-reading range and current/voltage (range codes 10 to 16).	
	Digital input trend	Digital input trends are printed for channels whose input range type is set to ON/OFF input.	
	Communications input trend	Written data is printed as measurement data by communications for channels whose input range type is set to communications input.	
	Measurement/calculation method	PV value, inter-channel deviation, deviation from fixed value, arithmetic operation (integration, F value, relative humidity)	
	Segment table offset	X (input) and Y (output) can be offset for conversion by a maximum of 14 segments. Three segment tables can be set.	
	Measurement range	DC voltage input: Any measurement (upper/lower limit values) can be set for each of the measurement ranges.	
Engineering range	DC voltage input: The engineering range (upper/lower limit value, decimal point position and unit) can be set within the range -19999 to 29999.		
Recording scale	Any recording scale (including reverse scaling) can be set for each channel within the range -19999 to 29999.		
Reference contact compensation	Thermocouple input: Compensation can be set ON/OFF for all channels (not independently). * When compensation is set to OFF, a reference contact compensation unit (such as an ice box) must be provided externally.		
Intrinsically safe system	100V ac is used as the lamp power supply on models with chart illumination lamp. So, an intrinsically safe system cannot be configured. When an intrinsically safe system is required, select a model without the chart illumination lamp, and connect a Zener barrier externally. If uneven resistance from the Zener barrier causes a temperature display error to occur, compensate for this by the PV bias. As the input wiring resistance exceeds 10 Ω , the accuracy compensation in Table 1 cannot be applied.		
Display	Digital display	Display method	Red and green 8-digit, 7-segment LED and 2 green LEDs for units (One of these is a 5-digit, green LED for displaying measurement values.)
		Measurement value display cycle	4s/measurement point
		Display information	• Measurement values • Channel No. • Alarm display • Date • Time • Chart feed speed • Other configuration data
	Lamp display	Display information	• Lights during recording and occurrence of an event. • Lights and displays information in the configuration and operation modes.
Re-corder	Recording method	Dot recording	Same color as wire dot + ink ribbon (6 colors)
		Dot size	Approx. 0.5 mm
		Trend recording cycle	Same as input measurement cycle When the chart feed speed is slow, and there are few changes in input, the dot recording cycle is automatically adjusted so that dots do not overlap.

Re-corder	Recording method	Recording color	Trend	Two types can be selected and set.																			
			Channel	1, 7, 13, 19	2, 8, 14, 20	3, 9, 15, 21	4, 10, 16, 22	5, 11, 17, 23	6, 12, 18, 24														
			Standard	Purple	Red	Green	Blue	Brown	Black														
			DIN	Purple	Red	Black	Green	Blue	Brown														
			Scale	Same color as trend color of each channel																			
			Tabulation recording	Same color as trend of each channel																			
			Time printing	PV value: Same color as trend color of each channel Time: purple																			
			Event	Occurrence:Red Restoration: Blue																			
			Channel No.	Same color as trend color of each channel																			
			Demand	PV value: Same color as trend color of each channel Time: purple																			
	Message	Purple																					
	Other	Purple																					
		Character structure	7 (V) x 5 (H) dot matrix																				
	Character recording	Recording at chart feed speed of 5 to 120 mm/h																					
Chart	Shape	Folding type																					
	Eff. recording width	-1.8 to 181.8 mm of calibration position (0%)																					
	Total length	20 m (plain paper), 16 m (clean paper)																					
	Replacement warning mark	Warning marks are output at 10 cm intervals from 60 cm from the end of the chart.																					
	Chart feed speed	1 to 480 mm/h, adjustable in 1 mm/h steps																					
	Trend recording resolution	0.1 mm																					
	Recording accuracy*	PV axis: Accuracy indicated in Table 1 + ($\pm 0.5\%$ of recording full scale) Time axis: ± 0.5 mm (*excluding chart shrinkage/elongation)																					
	(Reference)	Chart shrinkage/elongation: When the ambient humidity has changed from 60% to 85%RH: →Chart stretches by approx. 0.7%FS. When the ambient humidity has changed from 60% to 45%RH: →Chart shrinks by approx. 0.2%FS.																					
	Display/recording mode	One of the following four modes can be selected and set for each channel: • Display/recording OFF • Display only • Display/recording ON • Digital input-dependent																					
	Recording format	Trend recording	Trend	• PV value (analog) • Channel No.																			
Scale printing			• Marker/time (hours:minutes)/date/tag/unit/scale upper- and lower-limit values Or, • Marker/time (hours:minutes)/chart feed speed/tag/unit/scale upper- and lower-limit values																				
Event			• Marker (on trend) • Channel No./time (hours:minutes)/event No./relay output No./state (occurrence or reset)* * When a state occurs (is reset) before printing has finished, the next 24 items are memorized and printed.																				
Trend+tabulation recording		Trend	• PV value (analog) • Channel No. Or, • Marker/time (hours:minutes)/chart feed speed/tag/unit/scale upper- and lower-limit values																				
		Scale printing	• Marker/time (hours:minutes)/date/tag/unit/scale upper- and lower-limit values Or, • Marker/time (hours:minutes)/chart feed speed/tag/unit/scale upper- and lower-limit values																				
		Tabulation	• PV value is printed to left. Tabulation is carried out after printing of the scale. 6-dot model: 1 row, 6 columns 12-dot model: 2 rows, 6 columns 24-dot model: 4 rows, 6 columns Tabulation Cycle <table border="1" style="width: 100%; border-collapse: collapse;"> <tr> <td>Chart feed speed (mm/h)</td> <td>1 to 4</td> <td>5 to 10</td> <td>11 to 20</td> <td>21 to 40</td> <td>41 to 120</td> <td>121 to 480</td> </tr> <tr> <td>Print cycle (time)</td> <td>No printing</td> <td>12</td> <td>4</td> <td>2</td> <td>1</td> <td>No printing</td> </tr> </table>							Chart feed speed (mm/h)	1 to 4	5 to 10	11 to 20	21 to 40	41 to 120	121 to 480	Print cycle (time)	No printing	12	4	2	1	No printing
		Chart feed speed (mm/h)	1 to 4	5 to 10	11 to 20	21 to 40	41 to 120	121 to 480															
		Print cycle (time)	No printing	12	4	2	1	No printing															
Event		• Marker (on trend) • Channel No./time (hours:minutes)/event No./relay output No./state (occurrence or reset)* * When a state occurs (is reset) before printing has finished, the next 24 items are memorized and printed.																					
Trend+schedule demand		Trend	• PV value (analog) • Channel No.																				
	Schedule printing	• Marker/time (hours:minutes)/date/tag/unit/scale upper- and lower-limit values Or, • Marker/time (hours:minutes)/chart feed speed/tag/unit/scale upper- and lower-limit values																					

Recording format	Trend+schedule demand	Schedule demand	<ul style="list-style-type: none"> Time (hours:minutes)/PV value Up to 8 times can be set. 6-dot model: 1 row, 6 columns 12-dot model: 2 rows, 6 columns 24-dot model: 4 rows, 6 columns 	
		Event	<ul style="list-style-type: none"> Marker (on trend) • Channel No./time (hours:minutes)/event No./relay output No./state (occurrence or reset)* * When a state occurs (is reset) before printing has finished, the next 24 items are memorized and printed. 	
	Fixed interval tabulation (tabulation only)	Tabulation is carried out at a preselected fixed interval. Selectable cycle: Each 10 min/20 min/30 min/1 h/2 h/3 h/6 h/12 h/24 h		
	Fixed time tabulation (tabulation only)	Tabulation is carried out once at the start of printing, and carried out from then on at a preselected time. Selectable cycle: 00:05 to 23:59		
List printing	List printing	<ul style="list-style-type: none"> Print function lists: Parameters are printed out for each function categorized into four items. Print all lists: All parameters set in the configuration are printed out. A 4-item function list is printed out continuously. Print specified lists: Chart feed speed, range code, scale, unit, event setup, etc. 		
	User setup list printing	Any prepared list (within 85 characters x 3 lines) can be printed out as a list on the recording paper by a loader or communications.		
Event	Setting	Number of set events	4 events can be set for each channel.	
		Setting range	-19999 to 29999 (Selectable cycle)	
		Differential	0 to 29999 (Decimal point position varies according to range.)	
	Action	Event action is carried out even while recording has stopped (RCD OFF) OFF: Event action stopped LOW (measurement value lower limit alarm): Action when the PV and deviation values are at the event setup value or less HIGH (measurement value upper limit alarm): Action when the PV and deviation values are at the event setup value or more		
	Action result	Recording	<ul style="list-style-type: none"> Channel No. Event state 	<ul style="list-style-type: none"> Event occurrence/reset Relay output number (on relay output supported models)
		Display	<ul style="list-style-type: none"> Event state and measurement value when an event occurs Event occurrence/reset state on other channels 	
		Buffer	Up to 24 recording actions are memorized. (These are cleared when the power is turned OFF.)	
		Output	Relay output, open collector output or output to internal contact inputs possible	
Optional functions	External switch inputs	Number of inputs	4, 8, 12	
		Functions	Functions operate by assigning the following: <ul style="list-style-type: none"> Recording start/stop Print on demand Print all lists Print specified lists Print communications list Chart feed Chart feed speed/scale selection Clear batch counter Reset total Print messages 1 to 8 (12 characters each) Recording mode selection BIN code entry 	
		Contact hold time	500 ms min.	
		Switch type	Alternate	
		Open voltage	Approx. 5 V	
		Short-circuit current	Approx. 6 mA	
		Relay outputs	Number of outputs	6, 12
	Output action		4 event actions (max. 96 actions) preset to each channel can be freely combined to select OR or AND output, hold/non-hold or excitation/non-excitation.	
	Output type		Transfer contact (NC, NO contact)	
	Contact Rating		250V ac, 3 A, non-inductive load	
			30V dc, 3A, non-inductive load	
			Min. load 5V dc, 10 mA	
	Electrical life	100,000 operations (resistive load)		
	Open collector outputs	Number of outputs	12 + 3 (special outputs)	
Output action		4 event actions preset to each channel can be freely combined, and three OR or AND special outputs turn ON under the following conditions: <ul style="list-style-type: none"> At power ON During recording When an error is detected by self diagnostics 		

Optional functions	Open collector outputs	Allowable power voltage range	10 to 29V dc			
		ON residual voltage	1.6 V max.			
		OFF leakage current	0.1 mA max.			
	Event re-output	When 2 or more event outputs are connected by OR operation, the events are output again when a new event occurs.				
	Chart illumination lamp	Cold-cathode discharge tube				
	Communications	Communications standard	Standard	RS-232C		RS-485
			Number of signal lines	3 (including SG)		5 (including SG)
			Transmission distance	15 m max.		300 m max.
		Protocol	Standard	Yamatake-Honeywell CPL communications		Yamatake-Honeywell CPL communications
			Network	1-1		Multi-drop (max. 31 nodes)
Function			Slave station function		Slave station function	
Master station			Not specified		Not specified	
Communications system		Synchronization	Start-stop synchronization		Start-stop synchronization	
		Communications flow	Half duplex		Half duplex	
		Transmission speed	4800, 9600 bps		4800, 9600 bps	
		Data length	8 bits		8 bits	
		Parity	Even parity, no parity		Even parity, no parity	
		Stop bit	1 stop bit, 2 stop bits		1 stop bit, 2 stop bits	
General specifications	Memory protection	Setup data	EEPROM			
		Clock backup	Lithium cell (replace every 5 years): CR2430			
	Vibration resistance	0.98 m/s ² max. (0 to 100 Hz)				
	Insulation resistance	Min. 20 MΩ across each terminal and GND terminal (by 500V dc megger)				
	Dielectric strength	Power supply, relay output, open collector output (leak current 5 mA max.):				
		Across power terminal and GND terminal: 1500V ac 50/60 Hz for 1 minute Across relay output and GND terminal: 1500V ac 50/60 Hz for 1 minute Across open-collector output terminal and GND terminal: 500V ac 50/60 Hz for 1 minute Input (leak current 2 mA max.): Across measurement input terminal and GND terminal: 1000V ac 50/60 Hz for 1 minute Across measurement input terminals: 500V ac 50/60 Hz for 1 minute (excluding RTD input) Across external switch input terminal and GND terminal: 500V ac 50/60 Hz for 1 minute Across communications terminal and GND terminal: 500V ac 50/60 Hz for 1 minute				
	Induction resistance	Common mode rejection ratio: 120 dB (50/60 Hz±0.1 Hz, input impedance 500 Ω, across terminals and ground)				
		Normal mode rejection ratio: 40 dB (50/60 Hz±0.1 Hz)				
	Standard conditions	Temperature	23±2°C			
		Humidity	60±5%RH			
Voltage fluctuation		±1%				
Frequency fluctuation		±1%				
Vibration, noise, surge voltage		Not allowed				
Influence from other equipment		Not allowed				
Mounting		Horizontal				

General specifications	Operating conditions	Ambient temperature	0 to 50°C	
		Ambient humidity	30 to 90%RH (condensation not allowed)	
	Transportation/storage conditions	Ambient temperature	-20 to +60°C (-10 to +60°C for ink ribbon) At -20 to -10°C, only ink ribbon must be stored separately.	
		Ambient humidity	10 to 95%RH (condensation not allowed)	
		Shock resistance	294 m/s ² (continuously for 11 ms max.)	
		Vibration resistance	4.9 m/s ² max. (0 to 100 Hz)	
	Rated power voltage	100 to 240V ac, 50/60 Hz		
	Allowable voltage fluctuation	90 to 250V ac, 50/60 Hz		
	Power consumption	Approx. 50 VA (100 VA max.)		
	Rush current	Power voltage	Approx. 25 A (for 10 ms max.) at 100V ac Approx. 45 A (for 10 ms max.) at 200V ac	
	Material	Case	Steel plate	
		Door frame	Deformed PPE	
		Door window	Acryl	
	Color	Case	Frosted gray (DIC554 or equivalent)	
		Door frame	Surface matte gray (DIC554 or equivalent)	
	Weight	7 to 8 kg (Varies according to basic model No. and optional functions)		
Mounting	Panel mount, or horizontal or vertical gang-mounting			
Mounting angle	Bottom rear angle to 30° and top rear angle to 3° from horizontal position			

● Table 1 Input Types, Ranges and Display accuracy

Input			Range		Display accuracy (rdg refers to absolute value of indication value)	Resolution	
Type	Symbol	Code	mV/V input	mV/V indication range			
DC voltage	mV	00	±20 mV	-19999 to 29999	± (0.2% of rdg+3 digits)	10 μV	
		01	±40 mV	-19999 to 29999	± (0.2% of rdg+2 digits)	10 μV	
		02	±60 mV	-19999 to 29999	± (0.2% of rdg+2 digits)	10 μV	
		03	±200 mV	-19999 to 29999	± (0.2% of rdg+2 digits)	100 μV	
	V	04	±2 V	-19999 to 29999	± (0.2% of rdg+2 digits)	1 mV	
		05	±5 V	-19999 to 29999	± (0.2% of rdg+2 digits)	1 mV	
		06	0 to 10V	-19999 to 29999	± (0.2% of rdg+2 digits)	1 mV	
	mV	10	±20 mV	±20.00 mV	± (0.2% of rdg+3 digits)	10 μV	
		11	±40 mV	±40.00 mV	± (0.2% of rdg+2 digits)	10 μV	
		12	±60 mV	±60.00 mV	± (0.2% of rdg+2 digits)	10 μV	
		13	±200 mV	±200.0 mV	± (0.2% of rdg+2 digits)	100 μV	
	V	14	±2 V	±2.000 V	± (0.2% of rdg+2 digits)	1 mV	
		15	±5 V	±5.000 V	± (0.2% of rdg+2 digits)	1 mV	
		16	0 to 10 V	0 to 10.000 V	± (0.2% of rdg+2 digits)	1 mV	
	Type	Symbol	Code	°C Range		Display accuracy	Resolution
	Thermo-couple (note 1)	R	20	0.0 to 1760.0°C	0 to less than 100°C	±3.7°C	0.2°C
S		21	100 to less than 300°C		±1.5°C	0.2°C	
B		22	0.0 to 1820.0°C	300°C min.	± (0.15% of rdg+1°C)	0.2°C	
				Less than 400°C	±50°C	Not specified	
K		23	-200.0 to 1370.0°C	400 to less than 600°C	±3°C	0.3°C	
				600°C min.	± (0.15% of rdg+1°C)	0.2°C	
E		24	-200.0 to 800.0°C	-200 to less than -100°C	± (0.15% of rdg+1.5°C)	0.2°C	
				-100°C min.	± (0.15% of rdg+0.9°C)	0.2°C	
J		25	-200.0 to 1100.0°C	-200 to less than -100°C	± (0.15% of rdg+1°C)	0.2°C	
				-100°C min.	± (0.15% of rdg+0.7°C)	0.2°C	
T		26	-200.0 to 400.0°C	-200 to less than -100°C	± (0.15% of rdg+1°C)	0.2°C	
				-100°C min.	± (0.15% of rdg+0.6°C)	0.2°C	
N		27	0.0 to 1300.0°C	Entire range	± (0.15% of rdg+1°C)	0.2°C	
WRe0-26		28	0.0 to 2320.0°C	0 to less than 300°C	± (0.15% of rdg+10°C)	1.1°C	
	300 to less than 600°C			± (0.15% of rdg+1.5°C)	0.2°C		
WRe5-26	29	0.0 to 2320.0°C	600°C min.	± (0.15% of rdg+1°C)	0.2°C		
			0 to less than 300°C	± (0.15% of rdg+1.5°C)	0.2°C		
PR40-20	30	0.0 to 1880.0°C	300°C min.	± (0.15% of rdg+1°C)	0.2°C		
			0 to less than 500°C	±40°C	2.2°C		
PLII	31	0.0 to 1290.0°C	500 to less than 900°C	±12°C	0.7°		
			900 to less than 1500°C	± (0.3% of rdg+6°C)	0.4°C		
Ni-Ni•Mo	32	0.0 to 1200.0°C	1500°C min.	± (0.3% of rdg+3.5°C)	0.2°C		
			Entire range	± (0.15% of rdg+0.7°C)	0.2°C		
Resistance temperature detector (RTD)	Pt100	40	0.0 to 1200.0°C	Entire range	± (0.15% of rdg+0.7°C)	0.2°C	
	JPt100	41	-200.0 to 650.0°C	Entire range	± (0.15% of rdg+0.6°C)	0.2°C	
	JPt50	12	-200.0 to 550.0°C	Entire range	± (0.3% of rdg+1.2°C)	0.4°C	
	Ni508	43	-50.0 to 150.0°C	Entire range	± (0.15% of rdg+0.6°C)	0.2°C	

Type	Symbol	Code	°F Range	Display accuracy	Resolution	
Thermo-couple (note 1)	R	50	32 to 3200°F	32 to less than 212°F	±8°F	1°F
	S	51		212 to less 572°F	±4°F	1°F
				572°F min.	± (0.15% of rdg+3°F)	1°F
	B	52	32 to 3308°F	Less than 752°F	±90°F	Not specified
				752 to less than 1112°F	±6°F	2°F
				1112°F min.	±(0.15% of rdg+3°F)	1°F
	K	53	-328 to 2498°F	-328 to less than -148°F	± (0.15% of rdg+4°F)	1°F
				-148°F min.	± (0.15% of rdg+3°F)	1°F
	E	54	-328 to 1472°F	-328 to less than -148°F	± (0.15% of rdg+3°F)	1°F
				-148°F min.	± (0.15% of rdg+2°F)	1°F
	J	55	-328 to 2012°F	-328 to less than -148°F	± (0.15% of rdg+3°F)	1°F
				-148°F min.	± (0.15% of rdg+2°F)	1°F
	T	56	-328 to 752°F	-328 to less than -148°F	± (0.15% of rdg+3°F)	1°F
				-148°F min.	± (0.15% of rdg+2°F)	1°F
N	57	32 to 2372°F	Entire range	± (0.15% of rdg+3°F)	1°F	
WRe0-26	58	32 to 4208°F	32 to less than 572°F	± (0.15% of rdg+19°F)	3°F	
			32 to less than 572°F	± (0.15% of rdg+4°F)	1°F	
			1112°F min.	± (0.15% of rdg+3°F)	1°F	
WRe5-26	59	32 to 4208°F	32 to less than 572°F	± (0.15% of rdg+4°F)	1°F	
			572°F min.	± (0.15% of rdg+3°F)	1°F	
PR40-20	60	32 to 3416°F	32 to less than 932°F	±73°F	5°F	
			932 to less than 1652°F	±23°F	2°F	
			1652 to less than 2732°F	± (0.3% of rdg+12°F)	2°F	
			2732°F min.	± (0.3% of rdg+7°F)	1°F	
PLII	61	32 to 2354°F	Entire range	± (0.15% of rdg+2°F)	1°F	
Ni-Ni-Mo	62	32 to 2192°F	Entire range	± (0.15% of rdg+2°F)	1°F	
Resistance temperature detector (RTD)	Pt100	70	-328.0 to 1202.0°F	Entire range	± (0.15% of rdg+1.2°F)	0.5°F
	JPt100	71	-328.0 to 1022.0°F	Entire range	± (0.15% of rdg+1.2°F)	0.5°F
	JPt50	72	-328.0 to 1022.0°F	Entire range	± (0.3% of rdg+2.4°F)	1.0°F
	Ni508	73	-58.0 to 302.0°F	Entire range	± (0.15% of rdg+1.2°F)	0.5°F
Communica-tion (note 2)	—	80 to 87	-19999 to 29999	—	1	
ON/OFF signal (note 3)	—	90	—	—	1	

Note 1: Indication accuracy does not include reference contact compensation accuracy.

The final indication accuracy, when reference contact compensation is ON (default), is obtained by adding the following reference contact compensation accuracy to the indication accuracy in the tables.

Reference contact compensation accuracy

- Type: K, E, J, T, N, PLII, Ni-Ni-Mo: ±0.5°C/±1°F

Note that the reference contact compensation accuracy is as follows at low temperatures:

At K, E, J, T input -100°C/-148°F or less: ±1°C/±2°F

- Type: R, S, B, WRe0-26, WRe5-26: ±1°C/±2°F
- Type: PR40-20: ±2°C/±4°F

Note 2: Communications input: The data that is written to a specific address (see Communications Address Table) by communications is processed as PV values.

Note 3: ON/OFF signal: The data that is specified by the following sub-codes is processed as digital signals.

Digital signal No.	Digital Input Data Acquisition Destination	Supplementary Explanation
01 to 12	Relay outputs No.1 to No.12	These can be specified regardless of actual digital input or output. However, if an un-mounted digital input is specified, the setting is fixed at OFF.
13 to 24	Open collector outputs No.1 to No.12	
31 to 42	External switch inputs No.1 to No.12	
51 to 62	Internal contact inputs No.1 to No.12	

● MODEL SELECTION GUIDE I II III IV V VII VIII Example: SRF212AS20100

I	II	III	IV	V	VI	VII	VIII	Description
Basic Model No.	Power	Input	Option 1	Option 2	Option 3	Addition 1	Addition 2	
SRF206								180 mm 6-dot recorder
SRF212								180 mm 12-dot recorder
SRF224								180 mm 24-dot recorder
	A							100 to 240V ac, 50/60 Hz
		S						Full multi-input (standard specification)
			0					None
			1					Relay outputs (6)
			2					Relay outputs (6) + external switch outputs (4)
			4					Relay outputs (12)
			5					Relay outputs (12) + external switch outputs (8)
			7					Relay outputs (12) + open collector outputs (12)
			8					Relay outputs (12) + open collector outputs (12) + external switch inputs (12)
				0				Communications not supported
				1				RS-485
				2				RS-232C
					0			None
					1			Chart illumination lamp provided
						0		None
						D		Inspection certificate provided
						T		Tropical treatment
						B		Tropical treatment + Inspection certificate provided
						Y		Traceability certificate provided
							0	None

EXTERNAL DIMENSIONS

(unit: mm)

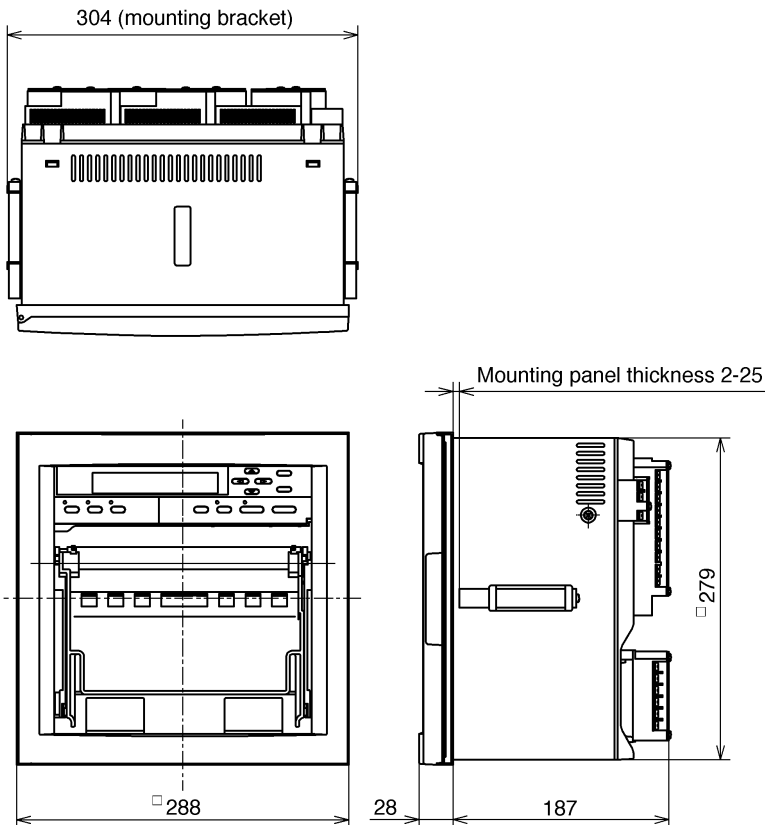

PANEL CUTOUT

(unit: mm)

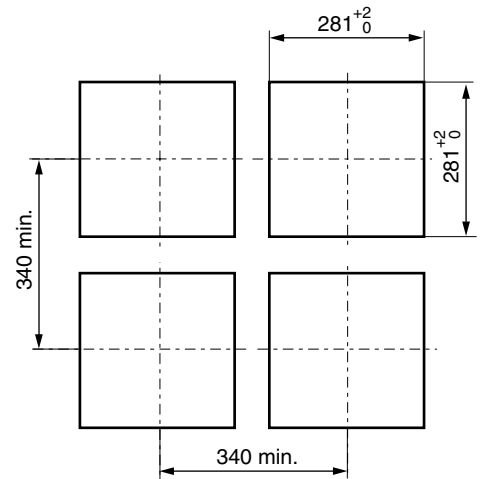

Attach one pair of mounting brackets either at the top or bottom or at the left and right of the Smart Recorder.

● Terminals on rear side

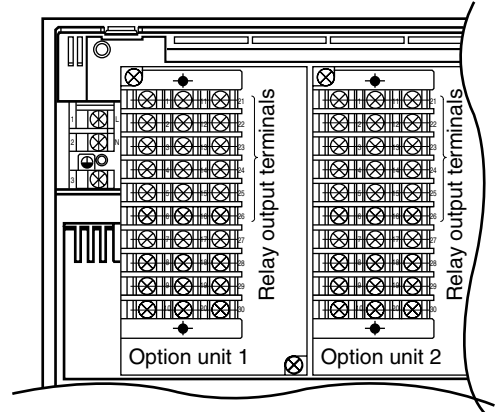
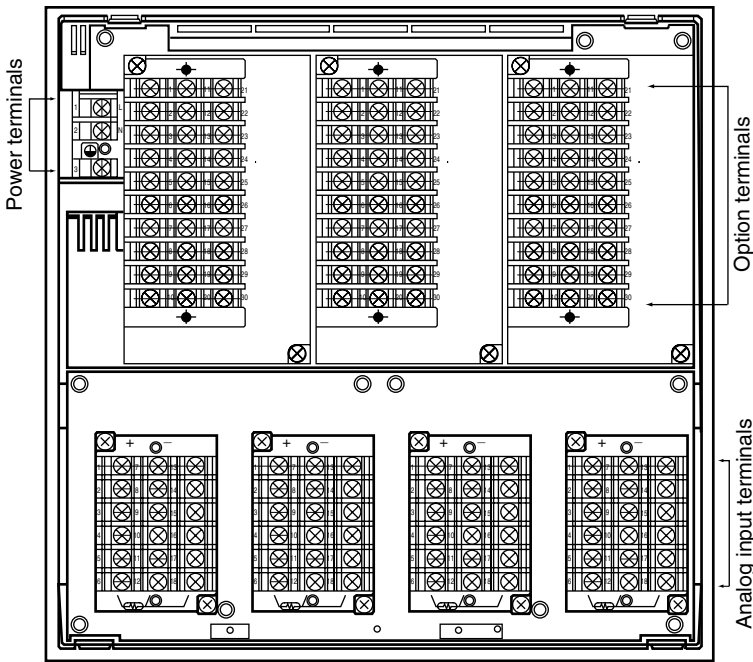

Option unit 1				Option unit 2			
Relay No.	Terminal No.	Relay No.	Terminal No.	Relay No.	Terminal No.	Relay No.	Terminal No.
—	NO COM NC	—	NO COM NC	—	NO COM NC	—	NO COM NC
1	1 11 21	7	1 11 21	1	1 11 21	7	1 11 21
2	2 12 22	8	2 12 22	2	2 12 22	8	2 12 22
3	3 13 23	9	3 13 23	3	3 13 23	9	3 13 23
4	4 14 24	10	4 14 24	4	4 14 24	10	4 14 24
5	5 15 25	11	5 15 25	5	5 15 25	11	5 15 25
6	6 16 26	12	6 16 26	6	6 16 26	12	6 16 26

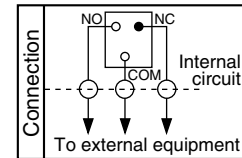

● Relay output wiring

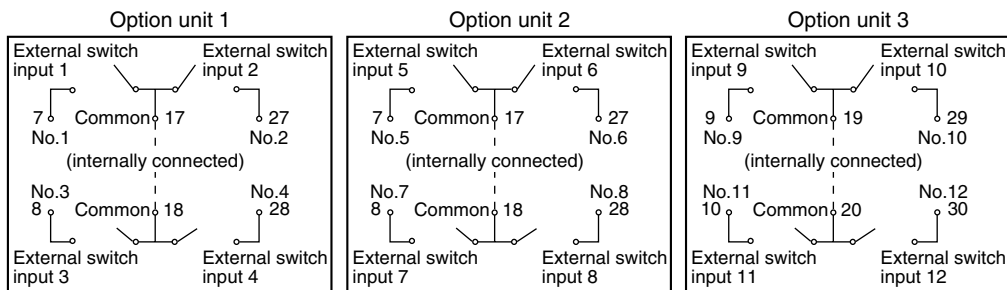
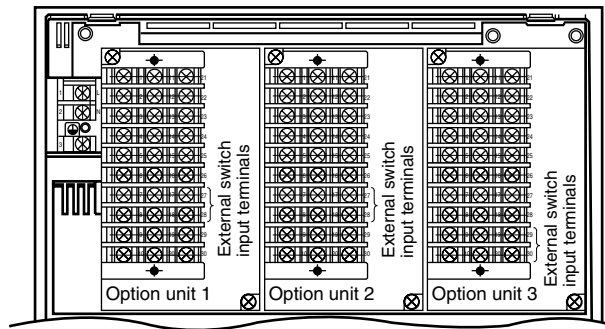

● External switch input wiring

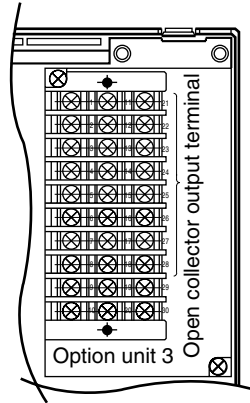

Terminal No.	Signal	Terminal No.	Signal	Terminal No.	Signal
1	Open collector output 1	11	Open collector output 2	21	+Power
2	Open collector output 3	12	Open collector output 4	22	GND *2
3	Open collector output 5	13	Open collector output 6	23	GND *2
4	Open collector output 7	14	Open collector output 8	24	+Power
5	Open collector output 9	15	Open collector output 10	25	GND *2
6	Open collector output 11	16	Open collector output 12	26	GND *2
7	Closed at recorder ON	17	Closed at power ON	27	+Power
8	Closed at self diagnostics error	18	GND *2	28	GND *2

*1: Mutually isolated

*2: Terminal Nos.18 and 23, 22 and 23, and 25 and 26 are electrically live inside the terminal.

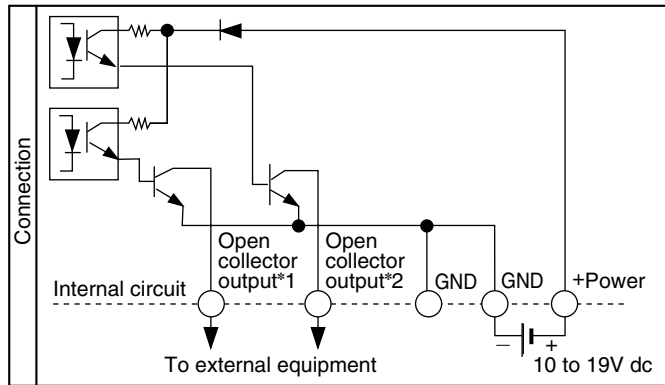

*1 and *2 indicate individual open collector output.

● Analog input wiring

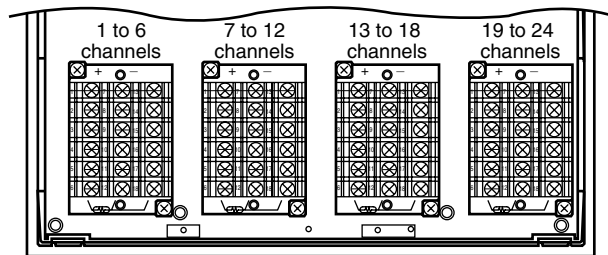

SRF206

SRF212

SRF224

Connection	DC voltage	Resistance temperature detector
Connection	Thermocouple	DC current input

* Attach a current-voltage converting fixed resistor.

● Open collector output wiring

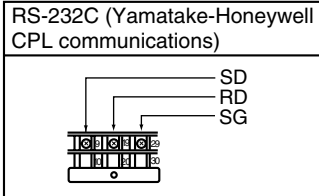
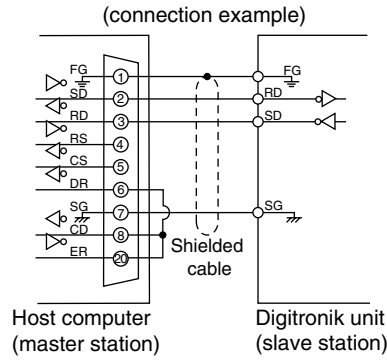
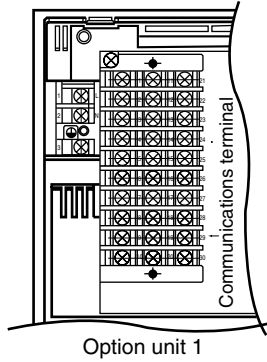

● RS-232C Connection

● RS-485 Connection

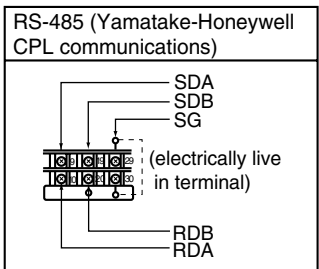
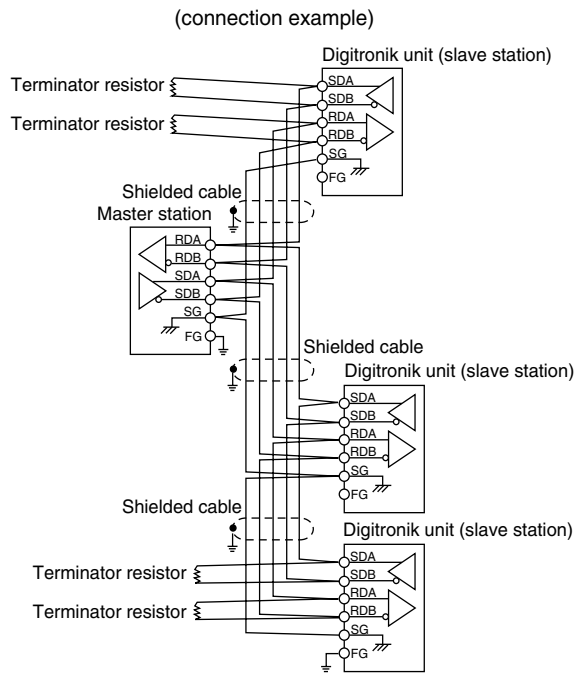
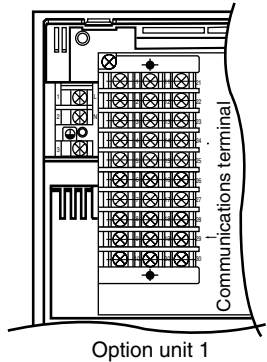

⚠ RESTRICTIONS ON USE

This product has been designed, developed and manufactured for general-purpose application in machinery and equipment. Accordingly, when used in the applications outlined below, special care should be taken to implement a fail-safe and/or redundant design concept as well as a periodic maintenance program.

- Safety devices for plant worker protection
- Start/stop control devices for transportation and material handling machines
- Aeronautical/aerospace machines
- Control devices for nuclear reactors

Never use this product in applications where human safety may be put at risk.

Specifications are subject to change without notice.

azbil

Yamatake Corporation
Advanced Automation Company

1-12-2 Kawana, Fujisawa
Kanagawa 251-8522 Japan
URL: <http://www.azbil.com>

Printed in Japan. (H)
1st Edition: Issued in Dec., 1997
2nd Edition: Issued in June, 1998

No part of this publication may be reproduced or duplicated without the prior written permission of Yamatake Corporation.

Printed on recycled paper.

(07)