

Compact Recorder CQ

The CQ Compact Recorder accommodates a 100mm wide chart, and comes in two types; pen type or dot printing type. The user can also choose from four available inputs; thermocouple, resistance temperature detector, DC voltage or DC current.

■ Features

- Five recording types are provided: 1-pen, 2-pen, 2-dot printing, 3-dot printing and 6-dot printing.
- The CQ is compactly designed and has a depth of only 150mm. This responds to customers' needs for shallower panels.
- Recording start and stop, and servo-lock setting and canceling can be controlled by external switch inputs.
- Alarm and burnout functions can be added, depending on the model number.
- A Carrying Handle can be installed at site, and is suitable for portable applications.
- Light weight (1-pen type: 1.8kg)
- The pen can be moved up or down, using the pen-up lever. (pen type only)
- The chart feed speed can be changed by replacing the gear (provided.)
- The pen can be easily replaced.
- Refilling of ink is not necessary, and the ink pad can be easily replaced. (dot printing type only)

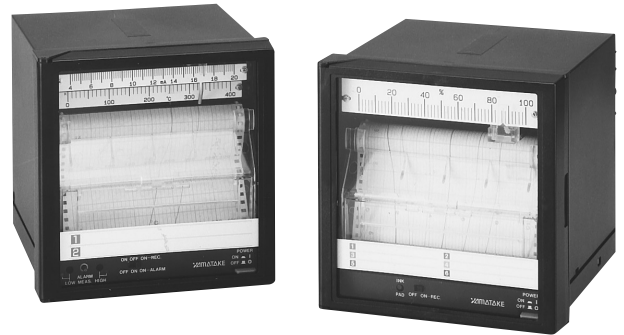

■ Performance Specifications

Input	Input type	Thermocouple, resistance temperature detector, DC voltage, DC current (See the Model No. table.)
	Range	See the Model No. table.
	Allowable wiring resistance	Thermocouple/DC voltage input: 2K Ω or less. However, 250 Ω or less in case of thermocouple input with burnout upper limit or lower limit. Resistance temperature detector: 10 Ω max. per lead (However, resistance of three leads must be balanced.)
	Input impedance	1M Ω min. (thermocouple, resistance temperature detector or DC voltage input) 250 Ω (DC current input)
	Burnout	Selectable from none, upper limit and lower limit according to the Model No. (only thermocouple input)
	Input bias current	Thermocouple/DC voltage input: \pm 50nA max. (\pm 100nA max. for a thermocouple input with burnout) Resistance temperature detector: Approx. 2mA
Display	Scaling method	Horizontal scale: Effective width of 100mm overall scale
	Scaling characteristics	Thermocouple/resistance temperature detector inputs: Temperature characteristic scaling DC voltage/DC current inputs: Linear scaling
	Display accuracy	\pm 0.5% FS (standard condition without burnout) See Table 2 Range (page 6) for exceptions to the above.
	Dead band	0.3% FS (standard condition)
Recorder	Recording method and recording color	1-pen: Red 2-pen: Channel 1 (red), Channel 2 (blue) 2-dot printing: Channel 1 (red), Channel 2 (blue) 3-dot printing: Channel 1 (red), Channel 2 (blue), Channel 3 (green) 6-dot printing: Channel 1 (red), Channel 2 (blue), Channel 3 (green), Channel 4 (pink), Channel 5 (purple), Channel 6 (brown)
	Pen speed (pen type)	Approx. 1s/FS or less
	Recording cycle (dot printing type)	2-dot: 12s 3-dot: 18s 6-dot: 36s
	Chart	Folding type, effective width of 100mm and 16m length

Recorder	Chart feed speed	Specify according to the Model No. 10mm/h (changeable to 20 or 40mm/h) 20mm/h (changeable to 40 or 80mm/h) 10mm/min (changeable to 20 or 40mm/min, applicable only on pen type) 20mm/min (changeable to 40 or 80mm/min, applicable only on pen type)
Alarm (option)	Alarm setting accuracy	±0.85% FS
	Control output differential	1.0% FS max.
	Alarm relay	SPDT (NO/NC), 250Vac 3A, 30Vdc 3A max. (at resistive load) Min. applicable load: 5Vdc 100mA, 24Vac 50mA
	Alarm type	Can be specified from one upper limit, one lower limit, one upper limit + one lower limit, two upper limits or two lower limits. On dot printing models, operation is carried out without the channel recognized. Note: Alarms are not provided on the 6-dot printing 2-type input model. On pen type models, only 1-channel models are recognized, and alarms are not provided on 2-channel models.
External switch input (option)	Function	Recording start/stop (dot printing type/pen type) and servo-lock setting/canceling (pen type only) (Note: The "servo-lock" is a function of latching the pen at the recording pen position regardless of PV input.)
	Switch type	Only dry contacts (Note: Open collector cannot be used.)
	Contact capacity	Servo-lock: 20Vdc, 500mA min. Recording start/stop: 20Vdc, 100mA min.
Other	Pen-up function	Pen can be raised by the lever. (pen type only)
	Limiter function	Connecting false inputs to unused channels is not necessary.

■ General Specifications

Insulation resistance	Min. 20MΩ across power terminal and GND terminal (by 500Vdc megger) Min. 20MΩ across input terminal and GND terminal (by 500Vdc megger)	
Dielectric strength	Across power terminal and GND terminal: 1500Vac for 1 minute (AC power supply model, leak current 5mA max.) Across input terminal and GND terminal: 1000Vac for 1 minute (AC power supply model, leak current 5mA max.) Across power terminal and GND terminal: 500Vac for 1 minute (DC power supply model, leak current 5mA max.) Across input terminal and GND terminal: 500Vac for 1 minute (DC power supply model, leak current 5mA max.)	
Induction resistance	Common mode rejection rate: 120dB, 250Vac max. Normal mode rejection rate: Max. 2X of 40dB span	
Standard conditions	Temperature	23±2°C
	Humidity	55±10% RH
	Voltage fluctuation	±1% of rated power voltage
	Power frequency fluctuation	±1% of rated power frequency (AC power supply model)
	Vibration, electrical noise or surge voltage	Not allowed
	Influence from other equipment	Not allowed
	Mounting	Horizontal
Operating conditions	Temperature	0 to 50°C
	Humidity	30 to 85% RH (condensation not allowed)
	Power voltage	±10% of rated power voltage
	Power frequency fluctuation	±2Hz of rated power frequency (AC power supply model)
	Vibration resistance	0.2m/s ² max. (10 to 60Hz)
	Mounting	Bottom rear angle to 30° from horizontal
Transportation/storage conditions	Ambient temperature	-20 to +60°C
	Ambient humidity	10 to 95% RH (no condensation allowed)
	Shock resistance	300m/s ² max. (continuously for 11 ms max.)
	Vibration resistance	5m/s ² max. (10 to 60Hz, for two hours in each of X, Y and Z axes)
Rated power voltage/frequency	According to the model No. specification 100, 110, 120, 200, 220, 240Vac 50Hz or 60Hz, and 12 and 24Vdc (pen type) 100, 110, 120, 200, 220, 240Vac 50/60Hz, and 12 and 24Vdc (dot printing model)	
Power consumption	7VA max. (1-pen type, AC power supply model) 11VA max. (2-pen type, AC power supply model) 13VA max. (dot printing type, AC power supply model) 7W max. (1-pen type, DC power supply model) 11W max. (2-pen type, DC power supply model) 13W max. (dot printing type, DC power supply model)	
Rush current	8A max. (10 ms max.)	
Material	Door	Deformed PPE, glass window
	Case	Deformed PPE
Color	Door frame	Black (standard)
	Case	Black (standard)
Mounting	Imbedded in indoor panel (changeable to a carrying type using carrying handle kit)	
Weight	Approx. 1.8kg (1-pen type), approx. 2.0kg (2-pen type and dot printing type)	
Standard accessories	Folding chart: 1 roll. Mounting bracket: 1 set. User's manual (CP-SP-1048E): 1. Pen: 1 set (pen type) or ink pad: 1 (dot printing type). Allen wrench: 1 (pen type). Screwdriver: 1 (pen type with alarm).	

■ How the Model Nos. are Configured

● Example of Model No.

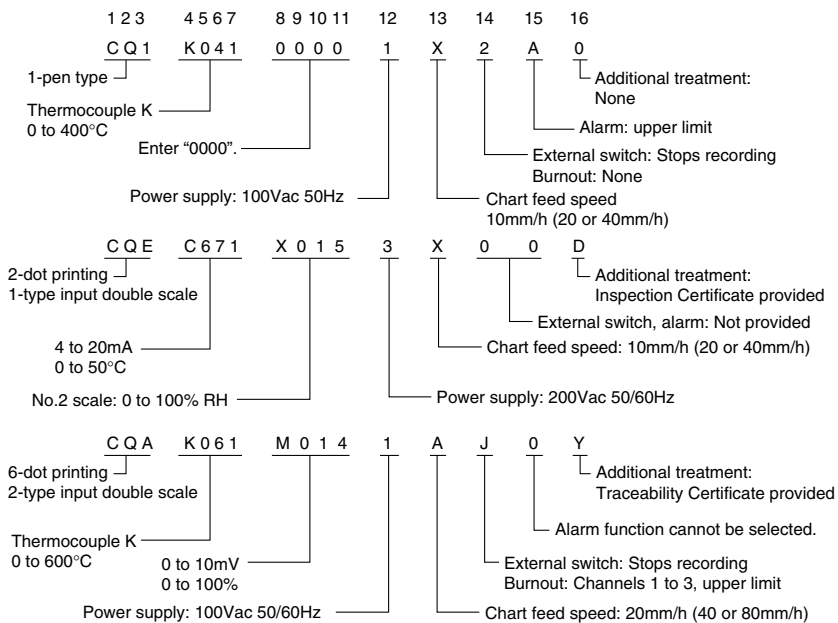

● 1-pen Type

1 2 3	4 5 6 7	8 9 10 11	12	13	14	15	16	Description
Basic Model No.	Input type Range Unit		Power voltage	Chart feed speed	Additional function		Additional treatment	
					External switch/burnout	Alarm		
CQ1								1-pen
	Table 1 to 3							Input type, range, unit
		0000						Enter "0000".
			Table 4					Select from Table 4.
				X				10mm/h (changeable to 20 or 40mm/h)*
				A				20mm/h (changeable to 40 or 80mm/h)*
				C				10mm/min (changeable to 20 or 40mm/min)*
				D				20mm/min (changeable to 40 or 80mm/min)*
					Table 6			Select from Table 6.
						Table 7		Select from Table 7.
							Table 10	Select from Table 10.

* The chart feed speed can be changed by replacing the gear (provided).

● 2-pen type

1 2 3	4 5 6 7	8 9 10 11	12	13	14	15	16	Description
Basic Model No.	Input type Range Unit		Power voltage	Chart feed speed	Additional function		Additional treatment	
					External switch/burnout	Alarm		
CQ2								2-pen
	Table 1 to 3							Input type, range and unit of channel 1
		Table 1 to 3						Input type, range and unit of channel 2
			Table 4					Select from Table 4.
				X				10mm/h (changeable to 20 or 40mm/h)*
				A				20mm/h (changeable to 40 or 80mm/h)*
				C				10mm/min (changeable to 20 or 40mm/min)*
				D				20mm/min (changeable to 40 or 80mm/min)*
					Table 6			Select from Table 6.
						Table 7		Select from Table 7.
							Table 10	Select from Table 10.

* The chart feed speed can be changed by replacing the gear (provided).

● Dot Printing Type/1-type Input Model

1 2 3	4 5 6 7	8 9 10 11	12	13	14 15	16	Description
Basic Model No.	Input type Range Unit		Power voltage	Chart feed speed	Additional function		
					External switch/burnout/alarm		
CQ3							3-dot printing, 1-type input
CQ6							6-dot printing, 1-type input
CQB							2-dot printing, 1-type input
	Table 1 to 3						Input type, range, unit
		0000					Enter "0000".
			Table 5				Select from Table 5.
				X			10mm/h (changeable to 20 or 40mm/h)*
				A			20mm/h (changeable to 40 or 80mm/h)*
					Table 8		Select from Table 8.
						Table 10	Select from Table 10.

* The chart feed speed can be changed by replacing the gear (provided).

● Dot Printing Type/1-type Input Double-scale Model

1 2 3	4 5 6 7	8	9 10 11	12	13	14 15	16	Description
Basic Model No.	Input type Range Unit		No.2 scale Range Unit	Power voltage	Chart feed speed	Additional function		
						External switch/burnout/alarm		
CQC								3-dot printing, 1-type input, double-scale
CQD								6-dot printing, 1-type input, double-scale
CQE								2-dot printing, 1-type input, double-scale
	Table 3							Input type, range, unit
		X						Enter "X".
			Table 2, 3					Specify range and unit of the No.2 scale range.
				Table 5				Select from Table 5.
					X			10mm/h (changeable to 20 or 40mm/h)*
					A			20mm/h (changeable to 40 or 80mm/h)*
						Table 8		Select from Table 8.
							Table 10	Select from Table 10.

* The chart feed speed can be changed by replacing the gear (provided).

● 6-dot Printing Type/2-type Input Double-scale Model

1 2 3	4 5 6 7 8 9 10 11	12	13	14	15	16	Description
Basic Model No.	Input type Range Unit	Power voltage	Chart feed speed	Additional function		Additional treatment	
				External switch/burnout	Alarm		
CQA							6-dot printing, 2-type input, double-scale
	Table 1 to 3						Input type, range and unit of channels 1 to 3
		Table 1 to 3					Input type, range and unit of channels 4 to 6
			Table 5				Select from Table 5.
				X			10mm/h (changeable to 20 or 40mm/h)*
				A			20mm/h (changeable to 40 or 80mm/h)*
					Table 9		Select from Table 9.
						0	Alarm function cannot be selected.
						Table 10	Select from Table 10.

* The chart feed speed can be changed by replacing the gear (provided).

● Model No. Configuration of Input Type, Range and Unit

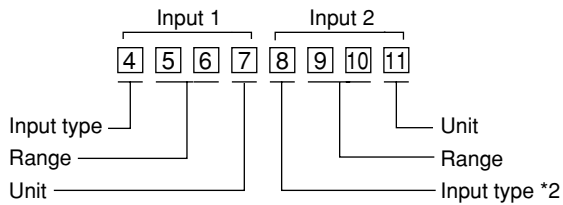

Model	Input 1	Input 2
1-pen type	Input type, range and unit of channel 1	"0000"
2-pen type	Input type, range and unit of channel 1	Input type, range and unit of channel 2
Dot printing type, 1-type input	Input type, range and unit of all channels	"0000"
Dot printing type, 1-type input, double-scale	Input type, range and unit of all channels	Range and unit of No.2 scale *
6-dot printing type, 2-type input, double-scale	Input type, range and unit of channels 1 to 3	Input type, range and unit of channels 4 to 6

* When using 1-type input double-scale model, enter "X" in the input 2 input type box.

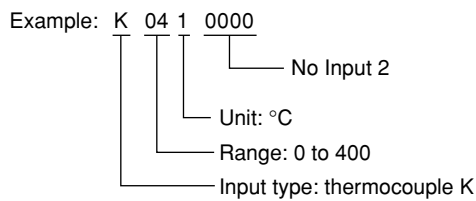

Table 1 Input type

Model No. Code	Input type
T	Thermocouple T (JIS C 1602-1981)
E	Thermocouple E (JIS C 1602-1981)
J	Thermocouple J (JIS C 1602-1981)
K	Thermocouple K (JIS C 1602-1981)
R	Thermocouple R (JIS C 1602-1981)
P	Resistance temperature detector Pt 100Ω (JIS C 1604-1989)
Q	Resistance temperature detector JPt 100Ω (JIS C 1604-1989)
C	4 to 20mA dc
V	1 to 5V dc
G	0 to 10V dc
M	0 to 10mV dc
L	-5 to +5mV dc

Table 2 Range

Model No. Code	Thermo-couple T	Thermo-couple E	Thermo-couple J	Thermo-couple K	Thermo-couple R
00					
01					
02	0 to 200		0 to 200	0 to 200*	
03	0 to 300	0 to 300	0 to 300	0 to 300	
04		0 to 400	0 to 400	0 to 400	
05				0 to 500	
06		0 to 600	0 to 600	0 to 600	
07					
08			0 to 800	0 to 800	
09					
10				0 to 1000	
11					
12				0 to 1200	0 to 1200
13					
14					0 to 1400
15					
16					0 to 1600
17					
18					
19					
20					
21					
22					
23					
24					
25					
26					
27					
28					
29					
30	-50 to +150			-50 to +150*	
31					
32					
33					
34					
35	-50 to +100*			-50 to +100*	
36					
37					
38					
39					
40					
41					
42					
43					
44					
45					
46	-100 to +200				
47					
48					
49					
50					

Model No. Code	Resistance Temperature Detector Pt100 P	Resistance Temperature Detector JPt100 Q
00		
01	0 to 100	0 to 100
02	0 to 200	0 to 200
03	0 to 300	0 to 300
04	0 to 400	0 to 400
05	0 to 500	0 to 500
06		
07		
08		
09		
10	0 to 50	0 to 50
11	0 to 150	0 to 150
12	0 to 250	0 to 250
13		
14		
15		
16		
17		
18		
19		
20		
21	100 to 200	100 to 200
22		
23		
24	50 to 100	50 to 100
25	50 to 150	50 to 150
26		
27		
28		
29		
30	-20 to +40	-20 to +40
31		
32	-25 to +25	-25 to +25
33	-40 to +80	-40 to +80
34	-50 to +50	-50 to +50
35	-50 to +150	-50 to +150
36	-20 to +60	-20 to +60
37	-20 to +80	-20 to +80
38	-10 to +40	-10 to +40
39		
40		
41	-50 to +100	-50 to +100
42	-50 to +200	-50 to +200
43		
44	-100 to +50	-100 to +50
45	-100 to +100	-100 to +100
46	-100 to +200	-100 to +200
47		
48		
49		
50		

*: Display accuracy $\pm 1.0\%$ FS (Standard conditions, without burnout)

Model No. Code	DC Current/ Voltage Range
00	Blank
01	0 to 100
01	0 to 200
03	0 to 300
04	0 to 400
05	0 to 500
06	0 to 600
07	0 to 700
08	0 to 800
09	0 to 900
10	-1 to 0
11	-1 to +1
12	-1 to +5
13	-1 to +10
14	-1 to +20
15	-1 to +35
16	-1 to +50
17	15 to 25
18	16 to 26
19	-25 to +25
20	-5 to +55
21	-5 to +60
22	-5 to +5
23	-4 to +4
24	-10 to +10
25	50 to 150
26	-30 to +10
27	-2 to +2
28	-3 to +3
29	

Model No. Code	DC Current/ Voltage Range
30	-20 to +40
31	-20 to +85
32	-25 to +25
33	-40 to +80
34	-50 to +50
35	-50 to +150
36	-20 to +60
37	-20 to +80
38	-50 to 0
39	-45 to +70
40	-200 to +100
41	-50 to +100
42	-50 to +200
43	-80 to +100
44	-100 to +50
45	-100 to +100
46	-100 to +200
47	-200 to 0
48	-200 to +50
49	-150 to +200
50	2 to 10
51	1 to 5
52	17 to 27
53	2 to 12
54	2 to 14
55	4 to 20
56	0 to 760
57	-760 to 0
58	800 to 1200
59	0 to 14

Model No. Code	DC Current/ Voltage Range
60	0 to 1
61	0 to 2
62	0 to 5
63	0 to 10
64	0 to 20
65	0 to 30
66	0 to 40
67	0 to 50
68	0 to 60
69	0 to 70
70	0 to 80
71	0 to 90
72	0 to 1000
73	0 to 2000
74	0 to 3000
75	0 to 4000
76	0 to 5000
77	0 to 6000
78	0 to 7000
79	0 to 8000
80	0 to 9000
81	0 to 3
82	0 to 4
83	0 to 6
84	0 to 7
85	0 to 8
86	0 to 12
87	0 to 15
88	0 to 16
89	0 to 18

Model No. Code	DC Current/ Voltage Range
90	0 to 25
91	0 to 35
92	0 to 45
93	0 to 150
94	0 to 250
95	0 to 350
96	0 to 450
97	0 to 1500
98	0 to 2500
99	0 to 3500
A0	0 to 4500
A1	0 to 0.1
A2	0 to 0.2
A3	0 to 0.3
A4	0 to 0.4
A5	0 to 0.5
A6	0 to 0.6
A7	0 to 0.7
A8	0 to 0.8
A9	0 to 0.9
B0	0 to 1.5
B1	0 to 2.5
B2	0 to 3.5
B3	0 to 4.5
B4	0 to 1200
B5	0 to 1400
B6	0 to 1600
B7	100 to 300
B8	200 to 400
B9	50 to 100

Table 3 Unit

Model No. Code	Unit
0	(no unit)
1	°C
3	pH
4	%
5	%RH
6	ppm
7	min ⁻¹
8	mg/ℓ
9	mV
A	m ³

Model No. Code	Unit
B	m ³ /min
C	m ³ /h
D	m ³ /h [Normal]
E	Hz
F	Ω
G	kΩ
H	MΩ
J	μs/cm
K	mm
L	cm

Model No. Code	Unit
M	m
N	t/h
P	ℓ/min
Q	ℓ/h
S	hPa
T	Pa
V	kPa
W	MPa
Y	ℓ
Z	A

Table 4 Power Supply (pen type model)

Model No. Code	Power Supply Specification
1	100Vac 50Hz
2	100Vac 60Hz
3	200Vac 50Hz
4	200Vac 60Hz
5	110Vac 50Hz
6	110Vac 60Hz

Model No. Code	Power Supply Specification
7	115Vac 50Hz
8	115Vac 60Hz
9	120Vac 50Hz
A	120Vac 60Hz
B	220Vac 50Hz
C	220Vac 60Hz

Model No. Code	Power Supply Specification
D	230Vac 50Hz
E	230Vac 60Hz
F	240Vac 50Hz
G	240Vac 60Hz
R	12Vdc
S	24Vdc

Table 5 Power Supply (dot printing type model)

Model No. Code	Power Supply Specification
1	100Vac 50Hz/60Hz
3	200Vac 50Hz/60Hz
5	110Vac 50Hz/60Hz
7	115Vac 50Hz/60Hz

Model No. Code	Power Supply Specification
9	120Vac 50Hz/60Hz
B	220Vac 50Hz/60Hz
D	230Vac 50Hz/60Hz
F	240Vac 50Hz/60Hz

Model No. Code	Power Supply Specification
R	12Vdc
S	24Vdc

Table 6 External Switch and Burnout (pen type model)

Model No. Code	External Switch Function	Burnout *		Applicable Model (Basic Model No.)
		Channel 1	Channel 2	
0	None	None	None	CQ1, CQ2
1	Servo-lock	None	None	CQ1, CQ2
2	Recording stop	None	None	CQ1, CQ2
3	Servo-lock, recording stop	None	None	CQ1, CQ2
A	None	Upper limit	None	CQ1, CQ2
B	None	Lower limit	None	CQ1, CQ2
C	None	Upper limit	Upper limit	CQ2
D	None	Lower limit	Lower limit	CQ2
E	Servo-lock	Upper limit	None	CQ1, CQ2
F	Servo-lock	Lower limit	None	CQ1, CQ2
G	Servo-lock	Upper limit	Upper limit	CQ2
H	Servo-lock	Lower limit	Lower limit	CQ2
J	Recording stop	Upper limit	None	CQ1, CQ2
K	Recording stop	Lower limit	None	CQ1, CQ2
L	Recording stop	Upper limit	Upper limit	CQ2
M	Recording stop	Lower limit	Lower limit	CQ2
N	Servo-lock, recording stop	Upper limit	None	CQ1, CQ2
P	Servo-lock, recording stop	Lower limit	None	CQ1, CQ2
Q	Servo-lock, recording stop	Upper limit	Upper limit	CQ2
R	Servo-lock, recording stop	Lower limit	Lower limit	CQ2
4	None	Upper limit	Lower limit	CQ2
5	None	Lower limit	Upper limit	CQ2
6	Servo-lock	Upper limit	Lower limit	CQ2
7	Servo-lock	Lower limit	Upper limit	CQ2
8	Recording stop	Upper limit	Lower limit	CQ2
9	Recording stop	Lower limit	Upper limit	CQ2
S	Servo-lock, recording stop	Upper limit	Lower limit	CQ2
T	Servo-lock, recording stop	Lower limit	Upper limit	CQ2

* One of "none", "lower limit" and "upper limit" can be selected for burnout only when a thermocouple input is used. The burnout function is not available when resistance temperature detector, DC voltage and DC current inputs are used. When these inputs are used, select "none".

Table 7 Alarm (pen type model)

Model No. Code	Alarm Type
0	None
A	Upper limit
B	Lower limit
C	Upper limit + lower limit
D	Upper limit + upper limit
E	Lower limit + lower limit

Note: Alarms for pen type models can be installed only on channel 1.

Table 8 External Switch, Burnout and Alarm (dot printing models excluding 2-type input)

Model Code No.	External Switch Function	Burnout *	Alarm Type	Application Model (basic model No.)
00	None	None	None	CQ3, CQ6, CQB, CQD, CQE
0A	None	None	Upper limit	CQ3, CQ6, CQB, CQD, CQE
0B	None	None	Lower limit	CQ3, CQ6, CQB, CQD, CQE
0C	None	None	Upper limit + lower limit	CQ3, CQ6, CQB, CQD, CQE
0D	None	None	Upper limit + upper limit	CQ3, CQ6, CQB, CQD, CQE
0E	None	None	Lower limit + lower limit	CQ3, CQ6, CQB, CQD, CQE
20	Recording stop	None	None	CQ3, CQ6, CQB, CQD, CQE
A0	None	Lower limit	None	CQ3, CQ6, CQB, CQD, CQE
AA	None	Lower limit	Upper limit	CQ3, CQ6, CQB, CQD, CQE
AB	None	Lower limit	Lower limit	CQ3, CQ6, CQB, CQD, CQE
AC	None	Lower limit	Upper limit + lower limit	CQ3, CQ6, CQB, CQD, CQE
AD	None	Lower limit	Upper limit + upper limit	CQ3, CQ6, CQB, CQD, CQE
AE	None	Lower limit	Lower limit + lower limit	CQ3, CQ6, CQB, CQD, CQE
B0	None	Upper limit	None	CQ3, CQ6, CQB, CQD, CQE
BA	None	Upper limit	Upper limit	CQ3, CQ6, CQB, CQD, CQE
BB	None	Upper limit	Lower limit	CQ3, CQ6, CQB, CQD, CQE
BC	None	Upper limit	Upper limit + lower limit	CQ3, CQ6, CQB, CQD, CQE
BD	None	Upper limit	Upper limit + upper limit	CQ3, CQ6, CQB, CQD, CQE
BE	None	Upper limit	Lower limit + lower limit	CQ3, CQ6, CQB, CQD, CQE
J0	Recording stop	Lower limit	None	CQ3, CQ6, CQB, CQD, CQE
K0	Recording stop	Upper limit	None	CQ3, CQ6, CQB, CQD, CQE

* One of "none", "lower limit" and "upper limit" can be selected for burnout only when a thermocouple input is used. The burnout function is not available when resistance temperature detector, DC voltage and DC current inputs are used. When these inputs are used, select "none".

Table 9 External Switch and Burnout (6-dot printing, 2-type input double scale)

Model No. Code	External Switch Function	Burnout *		Applicable Model (Basic Model No.)
		Channels 1 to 3	Channels 4 to 6	
0	None	None	None	CQA
2	Recording stop	None	None	CQA
A	None	Upper limit	None	CQA
B	None	Lower limit	None	CQA
C	None	Upper limit	Upper limit	CQA
D	None	Lower limit	Lower limit	CQA
J	Recording stop	Upper limit	None	CQA
K	Recording stop	Lower limit	None	CQA
L	Recording stop	Upper limit	Upper limit	CQA
M	Recording stop	Lower limit	Lower limit	CQA
4	None	Upper limit	Lower limit	CQA
5	None	Lower limit	Upper limit	CQA
8	Recording stop	Upper limit	Lower limit	CQA
9	Recording stop	Lower limit	Upper limit	CQA

* One of "none", "lower limit" and "upper limit" can be selected for burnout only when a thermocouple input is used. The burnout function is not available when resistance temperature detector, DC voltage and DC current inputs are used. When these inputs are used, select "none".

Table 10 Additional Treatment

Model No. Code	Mask Color	Inspection Certificate provided	Tropical Treatment	Traceability Certificate provided
0	Black	×	×	×
D	Black	○	×	×
T	Black	×	○	×
B	Black	○	○	×
Y	Black	×	×	○
1	Gray	×	×	×
2	Gray	○	×	×
3	Gray	×	○	×
4	Gray	○	○	×

Note: A circle (○) denotes availability.

■ Consumables

Model No.	Name	Applicable Model	Remarks
CRHL□□□*	Folding chart (length: 16 m)	All models	1 set (10 packets)
CRP100R	No.1 pen (red)	CQ1, CQ2	1 set (10 pens)
CRP100B	No.2 pen (blue)	CQ2	1 set (10 pens)
81446688-001	Ink pad (for 2-dot printing)	CQB, CQE	1 set (5 pcs)
81446689-001	Ink pad (for 3-dot printing)	CQ3, CQC	1 set (5 pcs)
81446690-001	Ink pad (for 6-dot printing)	CQ6, CQA, CQD	1 set (5 pcs)

* □□□ is configured as followed using "Table 1 Input Type" and "Table 2 Range".

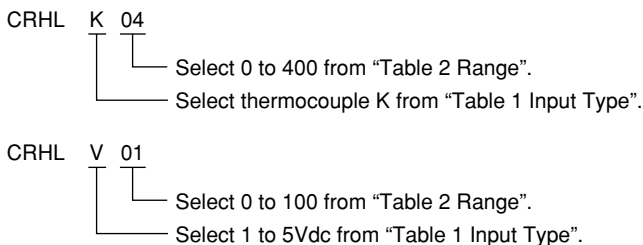

■ Optional Parts

Model No.	Name	Applicable Model	Remarks
81446695-001	Carrying handle kit	All models	Power supply lead set (sold separately)
81446696-001	Power supply cable set	(carrying handle kit)	One cable provided (for 100Vac)

External Dimensions

(Unit: mm)

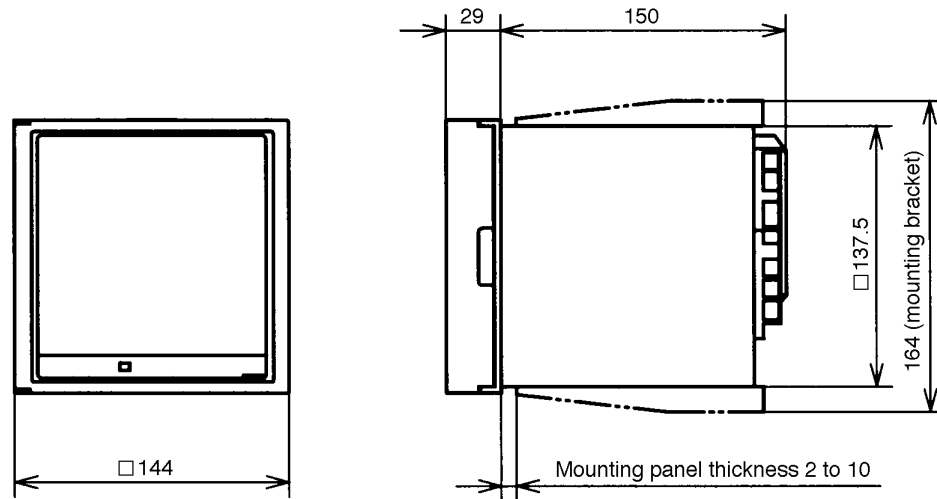

Installation Dimensions

Use a 2mm (or thicker) metal sheet or equivalent strength as the panel.
The panel cutout dimensions are as follows:

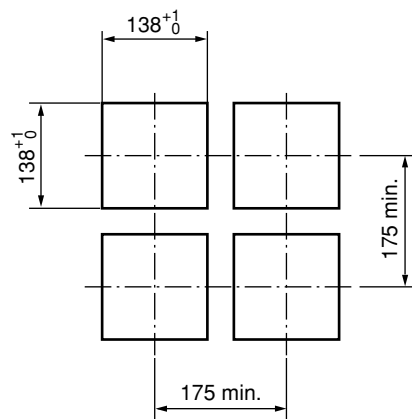

! Handling Precautions

This CQ recorder cannot be gang-mounted.

RESTRICTIONS ON USE

This product has been designed, developed and manufactured for general-purpose application in machinery and equipment. Accordingly, when used in the applications outlined below, special care should be taken to implement a fail-safe and/or redundant design concept as well as a periodic maintenance program.

- Safety devices for plant worker protection
- Start/stop control devices for transportation and material handling machines
- Aeronautical/aerospace machines
- Control devices for nuclear reactors

Never use this product in applications where human safety may be put at risk.

Specifications are subject to change without notice.

azbil

Yamatake Corporation Advanced Automation Company

1-12-2 Kawana, Fujisawa
Kanagawa 251-8522 Japan
URL: <http://www.azbil.com>

Printed in Japan. (H)
1st Edition: Issued in Apr., 1999
2nd Edition: Issued in Aug., 2006

No part of this publication may be reproduced or duplicated without the prior written permission of Yamatake Corporation.

Printed on recycled paper.

(07)