

# Single Loop Controller SDC15

## ■ Features

The DigitroniK SDC15 is a 48 x 48mm compact digital controller featuring group multi-range inputs and PID control system using new algorithms "Rationaloop PID (Ra-Pid)" and "Just-FiTTER".

Up to two control outputs (this number of points may vary depending on the model) can be used, which are selectable from the relay contact, voltage pulse, and current.

Two kinds of mounting methods are provided, panel mounting type and socket mounting type.

Additionally, this controller is compliant to the CE marking.

- Compact body with a depth of 60 mm.  
The mask of the front panel is also only 2 mm thick.
- The accuracy is  $\pm 0.5\%$ FS.
- The input type can be changed among the thermocouple input group, RTD group, and linear group.
- The control method can be selected from any of the ON/OFF control, PID control using "Rationaloop PID (Ra-Pid) + Just-FiTTER", and self-tuning.
- The heat and cool control can be achieved using two control outputs and event outputs.
- 18 kinds of operations, such as set (SP) value selection, RUN/READY selection, and latch cancellation, etc. can be set using two external switch inputs.
- The process variable (PV) value can be corrected.
- The controller uses 3-wire RS-485 communications.



- Up to eight points can be registered for the parameter keys, ensuring easy operation.
- Use of "mode" key ensures easy operation, RUN/READY, AUTO/MANUAL, and SP selections, and EV-relay latch cancellation.
- Up to three event outputs are provided.  
In addition to temperature events, such as PV, DEV, and SP, status events, such as CT heater burnout, over-current, and loop diagnosis can also be set.
- The controller is compliant to the CE marking (safety standards EN61010-1 and EN61326).
- Use of personal computer loader (optional unit) makes it possible to easily perform various settings, such as setup and parameter setting.
- Use of personal computer loader makes it possible to easily achieve the data logging from single unit to up to eight units.

## ■ Basic Function Block of SDC15

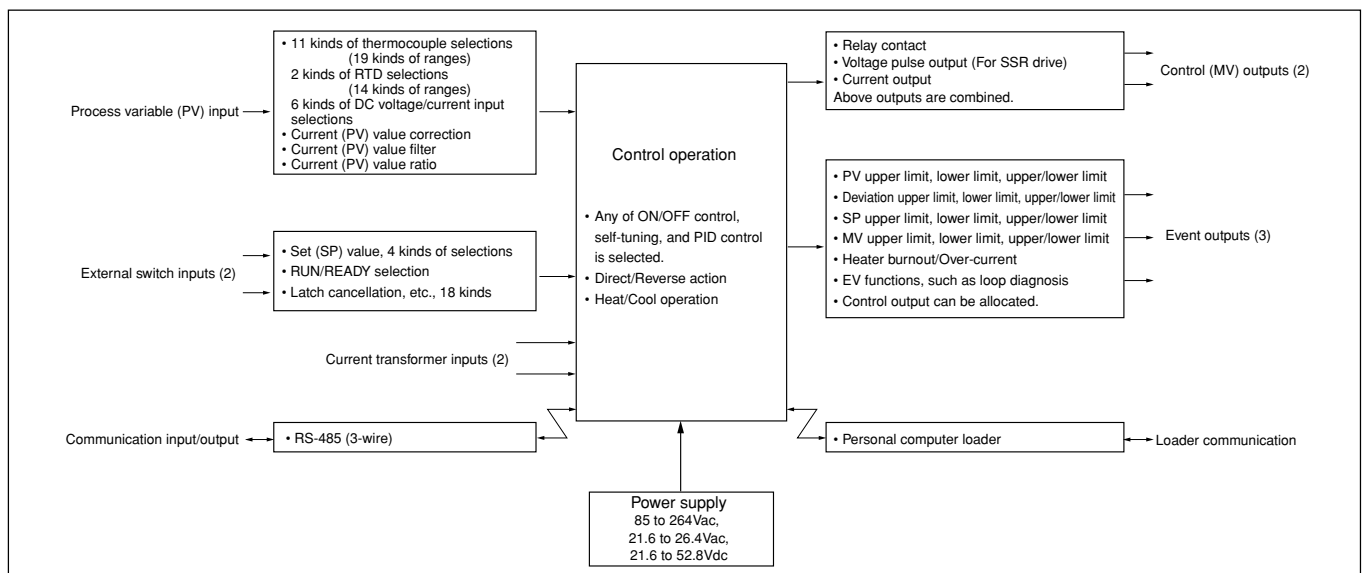

## ■ Specifications

<b>PV input</b>	Input type	Thermocouple, RTD, DC current, DC voltage (Selected by model. See Table 1.)			
	Sampling time	0.5s			
	Process variable (PV) correction	-1999 to +9999 or -199.9 to +999.9			
	Input bias current	Thermocouple input:	0.2μA or less (under standard conditions)		
		RTD input:	Approx. 1mA (flowed from A-terminal)		
		DC voltage input:	0 - 1V range:	1μA or less	
		0 - 5V, 1 - 5V range:	3.5μA or less		
		0 - 10V range:	7μA or less		
Effect of wiring resistance	Thermocouple input:	0.2μV/Ω or less			
	RTD input:	±0.05%FS/Ω or less			
	DC voltage input:	0 - 1V range:	1μV/Ω or less		
		0 - 5V, 1 - 5V range:	3.5μV/Ω or less		
		0 - 10V range:	7μV/Ω or less		
Display at burnout	Thermocouple input	Upscale + alarm display (AL01)			
	RTD input	RTD burnout: Upscale + alarm display (AL01)			
		A-wire burnout: Upscale + alarm display (AL01)			
		B-wire burnout: Upscale + alarm display (AL01, AL03)			
		C-wire burnout: Upscale + alarm display (AL01, AL03)			
		2- or 3-wire burnout: Upscale + alarm display (AL01, AL03)			
		A- and B-wire short-circuit: Downscale + alarm display (AL02)			
		A- and C-wire short-circuit: Downscale + alarm display (AL02)			
		DC voltage input: Downscale + alarm display (AL02)			
		However, a voltage input ranging from 0 to 10V cannot be detected.			
		DC current input: Downscale + alarm display (AL02)			
		However, a current input ranging from 0 to 20mA cannot be detected.			
<b>Indications and setting</b>	PV, SP indication method	4-digit, 7-segment LED (PV: Upper green display, SP: Lower orange display)			
	Number of setting points	Max. 4 points			
	Setting method	<, v, or ^ key operation at each digit			
	Setting range	See Table 1.			
	Indication accuracy	±0.5%FS±1 digit In the negative area of the thermocouple, the accuracy is ±1%FS±1 digit (at an ambient temperature of 23±2°C).			
	Indication range	See Table 1.			
	Indication and setting units	Thermocouple input:	1°C		
		RTD input:	1°C, 0.1°C (depending on the type of input)		
		DC voltage input/DC current input (programmable range):	1, 0.1, 0.01, 0.001		
	Settling value (SP) limit	Lower limit	Lower limit value of range to upper limit value of setting value (SP) limit		
		Upper limit	Lower limit value of setting value (SP) limit to upper limit value of range		
	Function display method	Digital 4-digit, 7-segment LED indication (Common to the PV display, displayed in green)			
	Status indication	EV1, EV2, EV3: Red LED lamp indication 0T1, 0T2 (control output), RDY (READY), MAN (power): Green LED lamp indication			
Display selection	Process variable (PV), Setting value (SP), Control output value, Heater current value, Time event remaining time, SP No.				
Key lock	Selected from the following three methods: • Key lock is activated in all modes. • Operable only for operation indications SP/EV/UF and parameter setting mode/SP/event. • Operable only for operation indications SP/EV/UF.				
Password	The data is protected by setting the password.				
<b>Control output</b>	Output type	<b>Relay contact</b>	<b>Voltage pulse (For SSR drive)</b>	<b>Current</b>	
	Control method	Selected from the following three methods: • ON/OFF control • Control with fixed PID value (PID control using "Rationaloop PID (Ra-Pid)" and "Just-FITTER") • Self-tuning			
	Output rating	Output rating: (Control output NO side) 250Vac/30Vdc, 3A (resistive load) (Control output NC side) 250Vac/30Vdc, 1A (resistive load) Service life: 50,000 cycles or more on NO side 100,000 cycles or more on NC side Min. opening/closing specifications: 5V, 100mA	Open voltage: 19Vdc±15% Internal resistance: 82Ω±0.5% Allowable current: Max. 24mAdc Leak current at OFF: Max. 100μA	Output type: 0 to 20mAdc or 4 to 20mAdc Allowable load resistance: Max. 600Ω Output accuracy: ±0.5%FS (However, 0 to 1mA ±1%FS)	
	Cycle time (s)	5 to 120	0.1, 0.25, 0.5, 1 to 120	—	
	PID control	Proportional band (%FS)	0.1 to 999.9		
		Integral time (s)	0 to 9999 (PD operation when I = 0)		
Derivative time (s)		0 to 9999 (PI operation when D = 0)			
Manual set (%)		-10.0 to 110.0 (only when I = 0)			

<b>Control output</b>	Just-FITTER	Overshoot suppression coefficient	0 to 100		
	ON/OFF control	Operation clearance (°C)	0 to 9999 or 0.0 to 999.9		
	Control operation selection	Direct action or reverse action			
	RUN/READY selection	Selected with the RDY key on the front panel or external contact input (In READY mode: Control output OFF)			
	Heat/Cool control selection	Control output and event output			
<b>External contact (digital input)</b>	Number of inputs	2			
	Function	Up to four kinds of setting value (SP) selections, RUN/READY selection, AUTO/MANUAL section, Auto tuning stop/start, Self-turning disable/enable, Control action Direct/Reverse selection, SP ramp enable/disable, PV value hold, Max. PV value hold, Min. PV value hold, Timer start/stop, All DO latch cancellation			
	Input rating	Non-voltage contact or open collector			
	Min. detection holding time	1s or longer			
	Allowable ON contact resistance	Max. 250Ω			
	Allowable OFF contact resistance	Min. 100kΩ			
	Allowable ON-state residual voltage	Max. 1.0V			
	Open terminal voltage	5.5Vdc±1V			
	ON terminal voltage	Approx. 7.5mA (at short-circuit), Approx. 5.0mA (at contact resistance of 250Ω)			
<b>Event</b>	Number of outputs	0 to 3 (depending on the model)			
	Number of internal event settings	Up to 5 settings			
	<b>Event type</b> ● shows that the ON/OFF is changed at this value. ○ shows that the ON/OFF is changed at a point that "1U" is added to this value.	<b>PV high limit</b>		<b>PV low limit</b>	
		<b>Direct action</b>	<b>Reverse action</b>	<b>Direct action</b>	<b>Reverse action</b>
		<b>PV high/low limit</b>		<b>Deviation high limit</b>	
		<b>Direct action</b>	<b>Reverse action</b>	<b>Direct action</b>	<b>Reverse action</b>
		<b>Deviation low limit</b>		<b>Deviation high/low limit</b>	
		<b>Direct action</b>	<b>Reverse action</b>	<b>Direct action</b>	<b>Reverse action</b>
		<b>SP high limit</b>		<b>SP low limit</b>	
		<b>Direct action</b>	<b>Reverse action</b>	<b>Direct action</b>	<b>Reverse action</b>
		<b>SP high/low limit</b>		<b>MV high limit</b>	
		<b>Direct action</b>	<b>Reverse action</b>	<b>Direct action</b>	<b>Reverse action</b>
		<b>MV low limit</b>		<b>MV high/low limit</b>	
		<b>Direct action</b>	<b>Reverse action</b>	<b>Direct action</b>	<b>Reverse action</b>
		<b>Heater burnout/Over-current</b>		<b>Heater short-circuit</b>	
		<b>Direct action</b>	<b>Reverse action</b>	<b>Direct action</b>	<b>Reverse action</b>

<b>Event</b>	<b>Event type</b> <ul style="list-style-type: none"> <li>● shows that the ON/OFF is changed at this value.</li> <li>○ shows that the ON/OFF is changed at a point that "1U" is added to this value.</li> </ul>	<b>Loop diagnosis 1</b>	
	<p>The event is turned ON when any change in PV corresponding to increase/decrease in MV (Manipulated variable) is not observed.  This event is used to detect any fault of final control devices.</p> <p><b>Setting items</b></p> <ul style="list-style-type: none"> <li>• Main setting: MV (Manipulated variable)</li> <li>• Sub-setting: PV</li> <li>• ON delay time: Diagnosis time</li> </ul> <p><b>Operation specifications</b></p> <p>The event is turned ON when the value does not reach the PV set in the sub-setting within the diagnosis time (ON delay time) even though the MV exceeding the main setting is held.</p> <p><b>CAUTION</b></p> <p>When setting the ON delay, it is necessary to put in "Multi-function setup".  The default setting of the ON delay before shipment is 0.0s.</p>		
	<b>Direct action</b>	<b>Reverse action</b>	
	<div style="display: flex; justify-content: space-between;"> <div style="width: 48%;"> <p><b>Heat control</b></p> <p>ON delay is started when conditions 1 and 2 are satisfied.</p> </div> <div style="width: 48%;"> <p><b>Cool control</b></p> <p>ON delay is started when conditions 1 and 2 are satisfied.</p> </div> </div>		
<b>Loop diagnosis 2</b>			
<p>The event is turned ON when any change in PV corresponding to increase/decrease in MV (Manipulated variable) is not observed.  This event is used to detect any fault of final control devices.</p> <p><b>Setting items</b></p> <ul style="list-style-type: none"> <li>• Main setting: MV (Manipulated variable)</li> <li>• Sub-setting: Change in PV from the point that the MV exceeds the main setting.</li> <li>• ON delay time: Diagnosis time</li> </ul> <p><b>Operation specifications</b></p> <p>The event is turned ON when the MV exceeding the main setting is held (conditions 2) and the PV does not reach the value that the sub-setting is added to (subtracted from) the PV at the point where the MV exceeds the main setting within the diagnosis time (ON delay time) (conditions 1).</p> <p><b>CAUTION</b></p> <p>When setting the ON delay, it is necessary to put in "Multi-function setup".  The default setting of the ON delay before shipment is 0.0s.</p>			
<b>Direct action</b>	<b>Reverse action</b>		
<div style="display: flex; justify-content: space-between;"> <div style="width: 48%;"> <p><b>Heat control</b></p> <p>ON delay is started when conditions 1 and 2 are satisfied.</p> </div> <div style="width: 48%;"> <p><b>Cool control</b></p> <p>ON delay is started when conditions 1 and 2 are satisfied.</p> </div> </div>			

<b>Event</b>	<b>Event type</b> <ul style="list-style-type: none"> <li>● shows that the ON/OFF is changed at this value.</li> <li>○ shows that the ON/OFF is changed at a point that "1U" is added to this value.</li> </ul>	<b>Loop diagnosis 1</b>		
	<p>The event is turned ON when any change in PV corresponding to increase/decrease in MV (Manipulated variable) is not observed. This event is used to detect any fault of final control devices.</p>			
	<ul style="list-style-type: none"> <li>● <b>Setting items</b> <ul style="list-style-type: none"> <li>• Main setting: Change in PV from the point that the MV reaches the upper limit (100%) or lower limit (0%).</li> <li>• Sub-setting: Range of absolute value of deviation (PV – SP) allowing the event to turn OFF.</li> <li>• ON delay time: Diagnosis time</li> <li>• OFF delay time: A period of time from power ON allowing the event to turn OFF.</li> </ul> </li> <li>● <b>Operation specifications</b> <ul style="list-style-type: none"> <li>• The direct action is used for the heat control. The event is turned ON when the increase in PV becomes smaller than the main setting after the diagnosis time (ON delay time) has elapsed from the time that the MV had reached the upper limit, or when the decrease in PV becomes smaller than the main setting from the time that the diagnosis time (ON delay time) has elapsed from the time that the MV had reached the lower limit.</li> <li>• The reverse action is used for the cool control. The event is turned ON when the decrease in PV becomes smaller than the main setting after the diagnosis time (ON delay time) has elapsed from the time that the MV had reached the upper limit, or when the increase in PV becomes smaller than the main setting after the diagnosis time (ON delay time) has elapsed from the time that the MV had reached the lower limit.</li> <li>• The event is turned OFF regardless of other conditions when the absolute value of the deviation (PV – SP) becomes less than the sub-setting.</li> <li>• The event is turned OFF regardless of other conditions when a period of time after starting of operation from the time that the power has been turned ON becomes less than the OFF delay time. However, the event is turned OFF when the absolute value of the deviation is the (sub-setting – hysteresis) value or less after the absolute value of the deviation has become the sub-setting or more.</li> </ul> </li> <li>● <b>CAUTION</b> When setting the ON delay and OFF delay, it is necessary to put in "Multi-function setup". The default settings of the ON delay and OFF delay before shipment are 0.0s.</li> </ul>			
	<b>Direct action</b>		<b>Reverse action</b>	
	Heat control		Cool control	
	ON delay is started when conditions 1 and 2 are satisfied.		ON delay is started when conditions 1 and 2 are satisfied.	
	<b>PV alarm (status)</b>			
	<b>Direct action</b>		<b>Reverse action</b>	
	ON if PV alarm (alarm code AL01 to 99) occurs, OFF in other cases.		OFF if PV alarm (alarm code AL01 to 99) occurs, ON in other cases.	
	<b>READY (status)</b>			
	<b>Direct action</b>		<b>Reverse action</b>	
	ON in the READY mode. OFF in the RUN mode.		OFF in the READY mode. ON in the RUN mode.	
	<b>MANUAL (status)</b>			
	<b>Direct action</b>		<b>Reverse action</b>	
ON in the MANUAL mode. OFF in the AUTO mode.		OFF in the MANUAL mode. ON in RUN mode.		
<b>During AT (Auto tuning)</b>				
<b>Direct action</b>		<b>Reverse action</b>		
ON while AT is running. OFF while AT is being stopped.		OFF while AT is running. ON while AT is being stopped.		
<b>During SP ramp</b>				
<b>Direct action</b>		<b>Reverse action</b>		
ON during SP ramp. OFF when SP ramp is not performed or is completed.		OFF during SP ramp. ON when SP ramp is not performed or is completed.		
<b>Control operation (status)</b>				
<b>Direct action</b>		<b>Reverse action</b>		
ON during direct action (cooling). OFF during reverse action (heating).		OFF during direct action (cooling). ON during reverse action (heating).		

<b>Event</b>	<p>Event type</p> <ul style="list-style-type: none"> <li>● shows that the ON/OFF is changed at this value.</li> <li>○ shows that the ON/OFF is changed at a point that "1U" is added to this value.</li> </ul>	<b>ST (Smart Tuning) setting standby (status)</b>		
		<b>Direct action</b>		
		<b>Reverse action</b>		
		<p>ON in the ST setting standby. OFF in the ST setting completion.</p>		
		<p>OFF in the ST setting standby. ON in the ST setting completion.</p>		
		<b>Timer (status)</b>		
		<p>The direct and reverse action settings are disabled for the timer event. When using the timer event, it is necessary to set the operation type of the DI allocation to "Timer Start/Stop". Additionally, when setting the event channel designation of the DI allocation, multiple timer events are controlled from individual internal contacts (DI).</p>		
		<ul style="list-style-type: none"> <li>● Setting items <ul style="list-style-type: none"> <li>• ON delay time: A period of time necessary to change the event from OFF to ON after DI has been changed from OFF to ON.</li> <li>• OFF delay time: A period of time necessary to change the event from ON to OFF after DI has been changed from ON to OFF.</li> </ul> </li> <li>● Operation specifications <ul style="list-style-type: none"> <li>• The event is turned ON when DI ON continues for ON delay time or longer.</li> <li>• The event is turned OFF when DI OFF continues for OFF delay time or longer.</li> <li>• In other cases, the current status is continued.</li> </ul> </li> </ul>		
		<ul style="list-style-type: none"> <li>● CAUTION</li> </ul> <p>When setting the ON delay and OFF delay, it is necessary to put in "Multi-function setup". The default settings of the ON delay and OFF delay before shipment are 0.0s. The default setting of the event channel designation of the DI allocation before shipment is "0". In this case, the timer event start/stop can be set for all internal events from one internal contact (DI). Additionally, as one or more event channel designation is set, the timer event start/stop can be set for one internal event specified by one internal contact (DI). However, when setting the event channel of the DI allocation, it is necessary to put in "Multi-function setup".</p>		
<p>Direct/Reverse action, standby, and READY operations can be set when setting up each event (E1.C1 to E5.C2).</p>				
Operating differential	0 to 9999 or 0.0 to 999.9			
Output operation	ON/OFF operation			
Output type	SPST relay contacts, Common for 3 contacts/independent contact for 2 contacts			
Output rating	250Vac/30Vdc, 2A (resistive load)			
Life	100,000 cycles or more			
Min. opening and closing specifications	5V, 10mA			
<b>Communication</b>	Communication system	Communication protocol	RS-485	
		Network	Multidrop, This device is provided with the slave station function. 1 to 31 units max.	
		Data flow	Half-duplex	
		Synchronization method	Start/stop synchronization	
	Interface	Transmission system	Balance (differential) type	
		Data line	Bit serial	
		Communication lines	3 transmit/receive lines	
		Transmission speed	4800, 9600, 19200, 38400 bps	
		Communication distance	500m max.	
		Protocol	RS-485 (3-wire type)	
	Message characters	Character configuration	11 bits/character	
		Data length	7 or 8 bits	
		Stop bit length	1 or 2 bits	
Parity bit		Even parity, odd parity, or non-parity		
<b>Loader communication</b>	Communication line	3-wire		
	Transmission speed	Fixed at 19200 bps		
	Recommended cable	Dedicated cable, 2 m long		
<b>Current transformer input</b>	Number of inputs	2		
	Detection function	Control output is ON.: Detection of heater line break or overcurrent Control output is OFF.: Detection of final control devices short-circuit		
	Input object	Number of current transformer windings: 800 turns QN206A (5.8mm-hole diameter)   Optional QN212A (12mm-hole diameter)   Optional		
	Measurement current range	0.4 to 50A		
	Indication range	0.0 to 70.0A		
	Indication accuracy	±5%FS±1 digit		

<b>Current transformer input</b>	Indication resolution	0.1A				
	Output	Selected from control output 1 and control output 2, or event output 1, event output 2, and event output 3.				
	Min. detection time	Burnout detection: Min. control output ON time 300ms or more Final control device short-circuit detection: Min. control output OFF time 300ms or more				
<b>General specifications</b>	Memory backup	Semiconductor non-volatile memory				
	Power supply voltage	AC power supply model: 85 to 264Vac, 50/60Hz±2Hz.				
		DC power supply model: 21.6 to 26.4Vac 50/60Hz±2Hz, 21.6 to 52.8Vdc				
	Power consumption	AC power supply model: 12VA or less.				
		DC power supply model: 72VA or less (24Vac), 5W or less (24 tp 48Vdc)				
	Insulation resistance	Between power supply terminal and secondary terminal, 500Vdc, 10MΩ or more				
	Dielectric strength	AC power supply model: Between power supply terminal and secondary terminal, 1500Vac for 1 min.				
		DC power supply model: Between power supply terminal and secondary terminal, 500Vac for 1 min.				
	Power ON inrush current	AC power supply model: 20A or less. DC power supply model: 20A or less.				
	Operating conditions	Ambient temperature	0 to 50°C (0 to 40°C for side-by-side mounting)			
		Ambient humidity	10 to 90%RH (No condensation allowed)			
		Vibration resistance	0 to 2m/s <sup>2</sup> (10 to 60Hz for 2 hrs. in each of X, Y, and Z directions)			
		Shock resistance	0 to 10m/s <sup>2</sup>			
		Mounting angle	Reference plane ±10°			
	Transportation conditions	Ambient temperature	-20 to +70°C			
		Ambient humidity	10 to 95%RH (No condensation allowed)			
		Package drop test	Drop height, 60cm, (1 corner, 3 sides, 6 planes, free fall)			
	Mask and case material	Mask: Polyester film, Case: Modified PPE				
	Mask and case color	Mask: Dark gray (DIC546), Case: Light gray (DIC650)				
Structure	IP66					
Conformed standards	EN61010-1, EN61326					
Installation category	Category II (IEC644-1, EN61010-1)					
Mounting	S type: Socket mounting (mounting with dedicated socket)					
	T type: Panel mounting (with dedicated mounting bracket)					
Weight	S type: Approx. 200g (including socket) T type: Approx. 150g (including dedicated mounting bracket)					
<b>Standard accessories</b>	<b>Part name</b>	<b>Model</b>	<b>Q'ty</b>	<b>Auxiliary parts (optional parts)</b>	<b>Part name</b>	<b>Model</b>
	Mounting bracket *1	81446403-001	1		Mounting bracket *2	81446403-001
	User's manual (Installation)	CP-UM-5287E	1		Gasket *3	81446918-001
	Gasket *1	81446918-001	1		Current transformer	QN206A (6mm-hole diameter) QN212A (12mm-hole diameter)
					Socket	81446391-001
				Hard cover	81446442-001	
				Soft cover	81446443-001	
				Terminal cover	81446898-001	

\*1 Supplied only with C15T.  
\*2 Connected to C15T.  
\*3 Standard accessory

**Table 1 Input Types and Ranges**

Input type	C01 No.	Sensor type	Range (°C)	Range (°F)
Thermo-couple	1	K	-200 to +1200	-300 to +2200
	2	K	0 to 1200	0 to 2200
	3	K	0 to 800	0 to 1500
	4	K	0 to 600	0 to 1100
	5	K	0 to 400	0 to 700
	6	K	-200 to +400	-300 to +700
	9	J	0 to 800	0 to 1500
	10	J	0 to 600	0 to 1100
	11	J	-200 to +400	-300 to +700
	13	E	0 to 600	0 to 1100
	14	T	-200 to +400	-300 to +700
	15	R	0 to 1600	0 to 3000
	16	S	0 to 1600	0 to 3000
	17	B	0 to 1800	0 to 3300
	18	N	0 to 1300	0 to 2300
	20	Wre5-26	0 to 1400	0 to 2400
	21	Wre5-26	0 to 2300	0 to 4200
	24	DIN U	-200 to +400	-300 to +700
25	DIN L	-100 to +800	-150 to +1500	

Input type	C01 No.	Sensor type	Range (°C)	Range (°F)
RTD	41	Pt100	-200 to +500	-300 to +900
	42	JPt100	-200 to +500	-300 to +900
	43	Pt100	-200 to +200	-300 to +400
	44	JPt100	-200 to +200	-300 to +400
	45	Pt100	-100 to +300	-150 to +500
	46	JPt100	-100 to +300	-150 to +500
	51	Pt100	-50.0 to +200.0	-50 to +400
	52	JPt100	-50.0 to +200.0	-50 to +400
	53	Pt100	-50.0 to +100.0	-50 to +200
	54	JPt100	-50.0 to +100.0	-50 to +200
	63	Pt100	0.0 to 200.0	0 to 400
	64	JPt100	0.0 to 200.0	0 to 400
	67	Pt100	0 to 500	0 to 900
	68	JPt100	0 to 500	0 to 900

Input type	C01 No.	Sensor type	Range
Linear input	84	0 to 1V	The scaling is made in a range of -1999 to +9999. The decimal point position can be changed variably.
	86	1 to 5V	
	87	0 to 5V	
	88	0 to 10V	
	89	0 to 20mA	
	90	4 to 20mA	

**! Handling Precautions**

- The accuracy of the B-thermocouple is ±5%FS at a temperature of 260°C or less and ±1%FS at a temperature of 260 to 800°C.
- The range having the decimal point is displayed to the 1st digit after the decimal point.
- The setup is made using C01 No. according to the sensor type and range to be used.

## ■ Model Selection Guide

I II III IV V VI VII Example: C15TR0TA0000

I	II	III	IV	V	VI	VII	Specifications	
Basic model No.	Mounting	Control output	PV input	Power supply	Option	Additional processing		
C15							Single Loop Controller	
	T						Panel mounting type	
(Note 1)	S						Socket mounting type	
							<b>Control output 1</b>	<b>Control output 2</b>
(Note 2)	R0						Relay output	None
	V0						Voltage pulse output (For SSR drive)	None
(Note 3)	VC						Voltage pulse output (For SSR drive)	Current output
(Note 3)	VV						Voltage pulse output (For SSR drive)	Voltage pulse output (For SSR drive)
	C0						Current output	None
(Note 3)	CC						Current output	Current output
			T				Thermocouple input (K, J, E, T, R, S, B, N, Wre5-26, DIN U, DIN L)	
			R				RTD input (Pt100/JPt100)	
			L				DC voltage/current input (0 to 1Vdc, 1 to 5Vdc, 0 to 5Vdc, 0 to 10Vdc, 0 to 20mAdc, 4 to 20mAdc)	
			A				AC Model (100 to 240Vac)	
			D				DC Model (24Vac/24 to 48Vdc)	
					00		None	
					01		Event relay outputs: 3	
				(Note 3, 4)	02		Event relay outputs: 3 Current transformer inputs: 2 Digital inputs: 2	
				(Note 3, 4)	03		Event relay outputs: 3 Current transformer input: 2 RS-485 communications	
				(Note 5)	04		Event relay outputs: 2 (independent contact)	
				(Note 3, 4, 5)	05		Event relay outputs: 2 (independent contact) Current transformer inputs: 2 Digital inputs: 2	
				(Note 3, 4, 5)	06		Event relay outputs: 2 (independent contact) Current transformer inputs: 2 RS-485 communications	
					00		No additional processing	
					D0		With inspection certificate	
					Y0		Traceability certificate available	

Note 1. Socket sold separately

Note 2. Only 1a contact is applicable for C15S

Note 3. Can not be selected for the C15S

Note 4. Current transformer sold separately

Note 5. Can not be selected for DC Model

## ■ Dimensions

### ● C15T (Panel mounting type)

(Unit: mm)

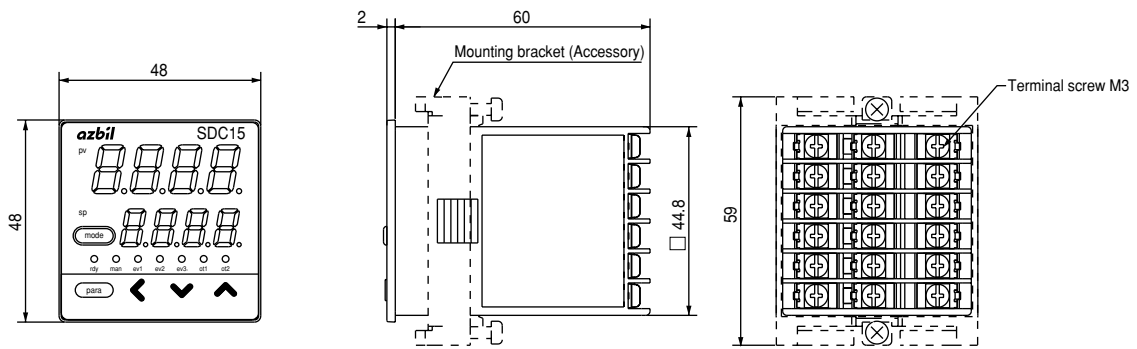

### ! Handling Precautions

Tighten the screws of the attached mounting bracket. When the mounting bracket is secured firmly so that no play exists, tighten the screws further by half-turn to fix the bracket to the panel. If the screws are tightened excessively, this may cause the case to deform.

### ● C15S (Socket mounting type)

### ● Socket 81446391-001 (Optional unit)

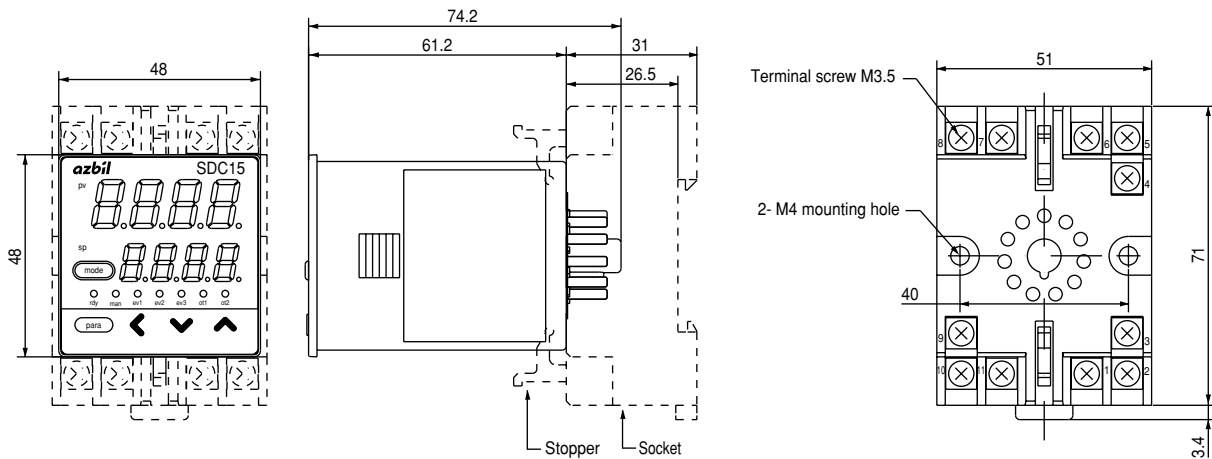

Put the stopper in the upper and lower holes in the main body of this controller and secure the socket firmly.

### ● Panel cutout diagram

#### Individual mounting

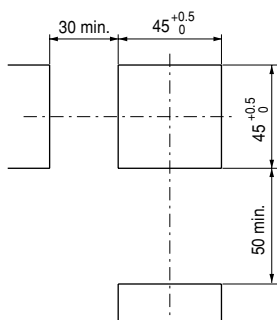

#### Side-by-side mounting

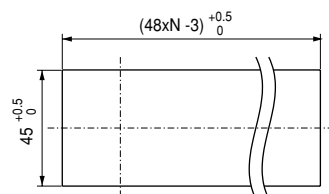

("N" shows the number of mounted units.)

### ! Handling Precautions

- When mounting three or more units tightly in the horizontal direction, pay special attention so that the ambient temperature does not exceed 40°C.
- When the water-proof structure is required, always mount the unit individually after the gasket supplied with this controller has been mounted on the main body.
- Keep a space of 50 mm or more in the vertical direction.

## ■ Part Names and Functions

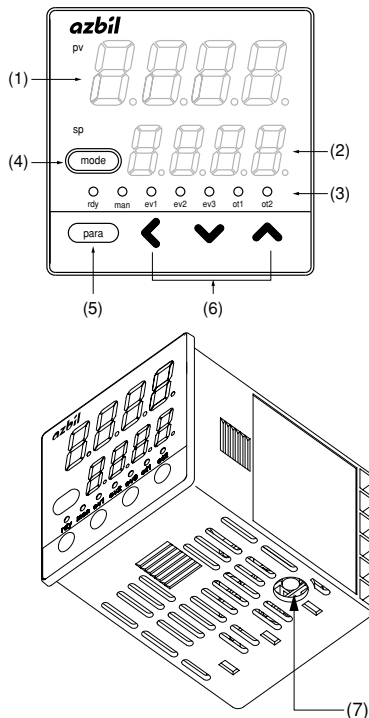

- (1) Display No. 1: Shows the PV value (current temperature, etc.) or setting items.
- (2) Display No. 2: Shows the SP value (set temperature, etc.) or the set value of each setting item.
- (3) Mode indicators
  - rdy : Lights in READY mode (control stop).
  - man: Lights in MANUAL mode (manual operation mode).
  - ev1 to ev3: Lights when event relay output is ON.
  - ot1 to ot2: Lights when control output is ON.
- (4) [mode] key: When this key is kept pressed for 1s or longer, the operation which has been set previously can be performed. The default setting before shipment is the RUN/READY selection.
- (5) [para] key: Changes the display.
- (6) <, v, ^ key: Increases or decreases the numeric value, or shifts the digit.
- (7) Loader connector: Connects a personal computer using the dedicated cable supplied with the Smart Loader Package.

## ■ Terminal Connection Diagram

### • Wiring of C15T

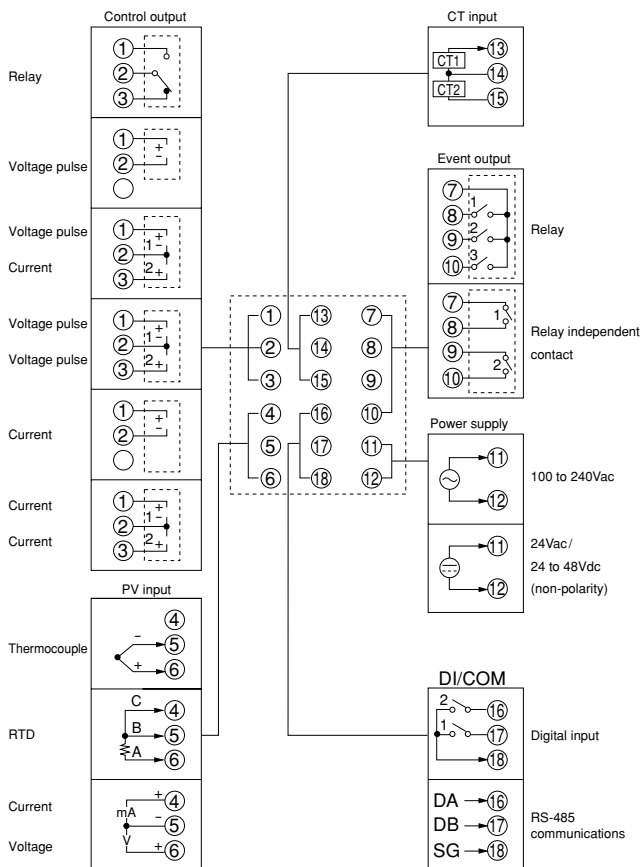

### • Wiring of C15S

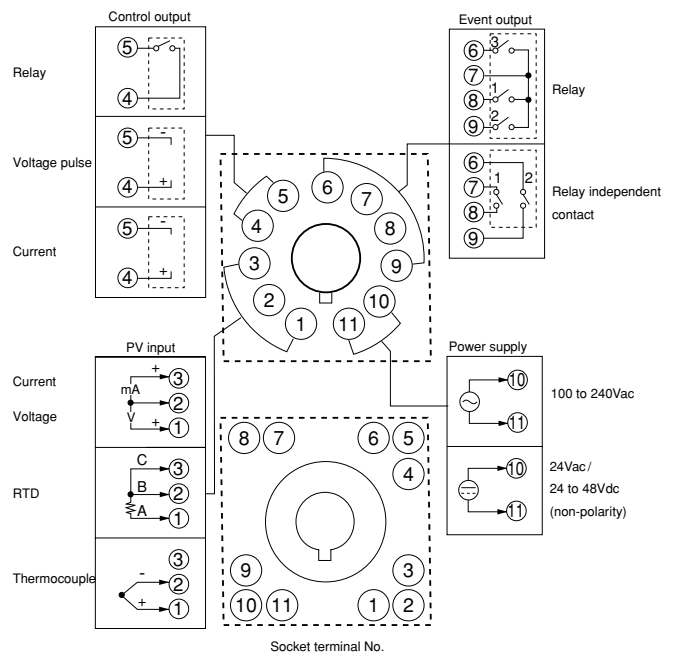

### ● Connection of RS-485 communications

RS-485 is a 3-wire connection.

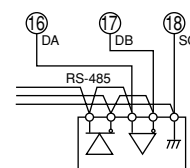

Example: Connection with 5-wire instrument

### ! Handling Precautions

Do not connect any external terminating resistor since a device similar to the terminating resistor is built-into this controller.

● **Precautions on the use of self-tuning function**

The final control devices must be powered up simultaneously with or prior to the instrument when the self-tuning function is to be used.

● **Precautions on wiring**

**1. Isolation within instrument**

Solid line portions " — " are isolated.

Dotted line portions " ---- " are not isolated.

Power supply		Internal circuit	Control output 1		
PV input			Control output 2		
CT input 1			Event output 1	Event output 1 (Independent contact)	
CT input 2				Event output 2	
Loader communication			Event output 2	Event output 1 (Independent contact)	
Digital input 1	RS-485	Event output 3	Event output 1 (Independent contact)		
Digital input 2	communications				

Available inputs and outputs may vary depending on the model.

**2. Preventive measures against noise of instrument power supply**

(1) Reduction of noise

Even though the noise is small, the noise filter is used to eliminate the effect of the noise as much as possible.

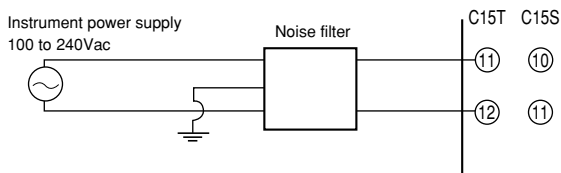

(2) When noise is excessive

If a large amount of noise exists, appropriate isolation transformer and line filter are used to eliminate the effect of the noise.

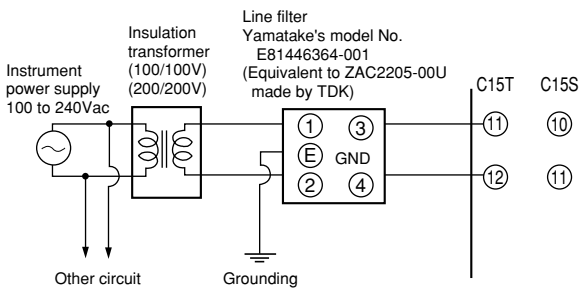

**3. Installation environment noise sources and preventive measures**

Generally, the following may be the noise sources in the installation environment:

Relay and contact, electromagnetic coil, solenoid valve, power supply line (particularly, 100Vac or more), motor commutator, phase angle control SCR, radio communication device, welding machine, high-voltage ignitor, etc.

**Preventive measures against fast rise noise**

Use of CR filter is effective to prevent fast rise noise.

Recommended filter:

Yamatake's model No. **81446365-001**

(Equivalent to 953M500333311 made by Matsuo Electric.)

**4. Wiring precautions**

- (1) After taking the noise preventive measures, do not bundle the primary and secondary power cables together or put both power cables in the same conduit or duct.
- (2) Keep the input/output and communication lines 50 cm or more away from the power lines and power supply lines having a voltage of 100Vac or more. Additionally, do not put these lines together in the same conduit or duct.

**5. Inspection after wiring**

After the wiring work has been completed, always inspect and check the wiring status. Great care should be taken since incorrect wiring may cause the instrument to malfunction or severe personal injury.



## RESTRICTIONS ON USE

This product has been designed, developed and manufactured for general-purpose application in machinery and equipment. Accordingly, when used in the applications outlined below, special care should be taken to implement a fail-safe and/or redundant design concept as well as a periodic maintenance program.

- **Safety devices for plant worker protection**
- **Start/stop control devices for transportation and material handling machines**
- **Aeronautical/aerospace machines**
- **Control devices for nuclear reactors**

Never use this product in applications where human safety may be put at risk.

*Specifications are subject to change without notice.*

**azbil**

### **Yamatake Corporation Advanced Automation Company**

1-12-2 Kawana, Fujisawa  
Kanagawa 251-8522 Japan  
URL: <http://www.azbil.com>

(H)  
1st Edition: Issued in May, 2003  
2nd Edition: Issued in Jun., 2008

*No part of this publication may be reproduced or duplicated without the prior written permission of Yamatake Corporation.*