MODEL 356G

Digital Resistance meter

Instruction Manual

I-02286

TSURUGA ELECTRIC CORPORATION

Contents

| | |
|---|--------|
| 1. Preface | - 1 - |
| 1.1●Preparation prior to use | - 1 - |
| 1.1.1 Inspection | - 1 - |
| 1.1.2 Storage..... | - 1 - |
| 1.2●Confirmations prior to use..... | - 2 - |
| 1.2.1 Power supply | - 2 - |
| 1.2.2 Power supply cable..... | - 2 - |
| 1.2.3 Replacement of fuse | - 2 - |
| 1.3●Warning and caution of measurement time..... | - 3 - |
| 1.3.1 Electric shock or failure..... | - 3 - |
| 1.3.2 Measurement of transformer and coil..... | - 3 - |
| 2. Name of parts..... | - 4 - |
| 2.1●Front panel..... | - 4 - |
| 2.2●Rear panel..... | - 6 - |
| 3. Function and method of operation | - 7 - |
| 3.1●Power supply | - 7 - |
| 3.2●Connection of measuring terminals..... | - 7 - |
| 3.2.1 Connection of resistance measurement terminals..... | - 7 - |
| 3.2.2 Connection of temperature measurement terminals..... | - 8 - |
| 3.3●Key lock | - 8 - |
| 3.4●Selection of measurement function | - 9 - |
| 3.4.1 Resistance display (OHM)..... | - 9 - |
| 3.4.2 Temperature correction function (T.C)..... | - 10 - |
| 3.4.3 Ratio display function (OHM RATIO)..... | - 11 - |
| 3.4.4 Temperature correction ration display function (T.C RATIO)..... | - 11 - |
| 3.4.5 Temperature display (TEMP)..... | - 12 - |
| 3.4.6 Measurement disorder detection..... | - 12 - |
| 3.5●Change-over of measuring range..... | - 13 - |
| 3.6●Selection of the sampling rate..... | - 13 - |
| 3.7●Zero adjustment..... | - 14 - |
| 3.7.1 Key operation | - 14 - |
| 3.7.2 Remote operation..... | - 14 - |
| 3.7.3 Communication operation..... | - 14 - |
| 3.7.4 Zero adjustment operation priority order | - 14 - |
| 3.8●Comparator..... | - 15 - |
| 3.8.1 Conditions for comparison..... | - 15 - |
| 3.8.2 Comparator output..... | - 15 - |
| 3.8.3 Setting method..... | - 15 - |
| 3.9●Buzzer | - 16 - |
| 3.9.1 Setting method..... | - 16 - |
| 3.10●Average calculation | - 17 - |
| 3.10.1 Setting method..... | - 17 - |
| 3.10.2 Operation of the average calculation..... | - 18 - |
| 3.11●Offset voltage correction function..... | - 19 - |
| 3.11.1 Setting method..... | - 20 - |
| 3.12●Start delay..... | - 21 - |
| 3.12.1 Setting method..... | - 22 - |
| 3.13●Measured current limit function | - 23 - |
| 3.13.1 Setting method..... | - 25 - |
| 3.14●Program memory..... | - 26 - |
| 3.14.1 Selection of program memory | - 26 - |
| 3.14.2 Registration of program memory..... | - 26 - |

| | |
|--|--------|
| 3.15●Temperature correction function..... | - 27 - |
| 3.15.1 Setting method..... | - 27 - |
| 3.16●Communication setting..... | - 28 - |
| 3.16.1 Setting method..... | - 28 - |
| 3.17●Memory and initialization of setting..... | - 29 - |
| 3.17.1 Setting method..... | - 30 - |
| 4. External control | - 31 - |
| 4.1●Remote connector..... | - 31 - |
| 4.1.1 Pin array..... | - 31 - |
| 4.1.2 Memory selection | - 32 - |
| 4.1.3 External control timing chart..... | - 33 - |
| 5. Communication (RS-232C, RS-485, USB)..... | - 38 - |
| 5.1●Specifications..... | - 38 - |
| 5.1.1 Specifications of RS-232C, RS-485..... | - 38 - |
| 5.1.2 Specifications of USB..... | - 38 - |
| 5.2●Connection | - 39 - |
| 5.2.1 Connection of RS-232C..... | - 39 - |
| 5.2.2 Connection of RS-485 | - 40 - |
| 5.2.3 Connection of USB..... | - 40 - |
| 5.3●Communication setting..... | - 40 - |
| 5.4●Operation description | - 41 - |
| 5.5●List of communication commands..... | - 41 - |
| 5.6●Data format..... | - 42 - |
| 5.6.1 Command frame | - 42 - |
| 5.6.2 Response frame..... | - 42 - |
| 5.7●Program data..... | - 43 - |
| 5.7.1 DATA? ... Read out of measurement data | - 43 - |
| 5.7.2 FUNC? ... Read out of function..... | - 46 - |
| 5.7.3 FUNCTION= ... Setting of function | - 46 - |
| 5.7.4 RANGE? ... Read out of measurement range..... | - 47 - |
| 5.7.5 RANGE= ... Setting of range..... | - 47 - |
| 5.7.6 SAMPLING? ... Read out of sampling | - 48 - |
| 5.7.7 SAMPLING= ... Setting of sampling..... | - 48 - |
| 5.7.8 AVERAGE? ... Read out of average no. of times | - 49 - |
| 5.7.9 AVERAGE= ... Average no. of times setting | - 49 - |
| 5.7.10 COMP? ... Read out of comparator setting | - 50 - |
| 5.7.11 COMP= ... Comparator setting | - 51 - |
| 5.7.12 RATIOSTD? ... Read out the ratio setting..... | - 52 - |
| 5.7.13 RATIOSTD= ... Ratio setting..... | - 53 - |
| 5.7.14 MEM? ... Read out of memory no. | - 54 - |
| 5.7.15 MEM=CALL ... Switching of memory no..... | - 54 - |
| 5.7.16 MEM01? ... Read out of memory setting contents..... | - 55 - |
| 5.7.17 WRITE MEMORY ... Storage of memory | - 56 - |
| 5.7.18 ONLINE? ... Read out of online status | - 57 - |
| 5.7.19 ONLINE= ... Setting of online..... | - 57 - |
| 5.7.20 HOLD? ... Read out of HOLD state..... | - 58 - |
| 5.7.21 HOLD= ... Setting of HOLD | - 58 - |
| 5.7.22 RST? ... Read out of reset state..... | - 59 - |
| 5.7.23 RST= ... Setting of reset..... | - 59 - |
| 5.7.24 ZEROADJ? ... Read out of zero adjustment state..... | - 60 - |
| 5.7.25 ZEROADJ= ... Setting of zero adjustment..... | - 60 - |
| 5.7.26 READ ... Sampling data output..... | - 61 - |

| | |
|--|--------|
| 6. Analog output | - 62 - |
| 6.1●Output specifications | - 62 - |
| 7. BCD output | - 63 - |
| 7.1●Output specifications | - 63 - |
| 7.1.1 TTL output (-03) | - 63 - |
| 7.1.2 Open collector output (-04) | - 63 - |
| 7.2●Connector pin array..... | - 64 - |
| 7.3●Descriptions of input and output signals | - 65 - |
| 7.3.1 Output signal..... | - 65 - |
| 7.3.2 Input signal..... | - 65 - |
| 7.3.3 Description of signals..... | - 66 - |
| 7.4●Timing chart | - 67 - |
| 8. Calibration..... | - 68 - |
| 8.1●Things needed for preparation..... | - 68 - |
| 8.2●Calibration method..... | - 68 - |
| 8.2.1 Calibration of resistance measurement range..... | - 68 - |
| 8.2.2 Calibration of temperature..... | - 69 - |
| 8.2.3 Calibration of analog output | - 70 - |
| 9. Specifications | - 71 - |
| 9.1●Model name..... | - 71 - |
| 9.2●Measurement range..... | - 71 - |
| 9.3●General specifications..... | - 72 - |
| 10. Dimensions..... | - 73 - |
| 11. Maintenance and calibration..... | - 74 - |
| 11.1●Cleaning | - 74 - |
| 11.2●Problem solving..... | - 74 - |
| 11.4●Error display | - 75 - |

1. Preface

Make sure that this instruction manual is available to the responsible person using this meter. In order to use this meter properly, read the instruction manual before using.

Caution

- To avoid break-down, malfunction or deterioration of life time, don't use this meter in such places where:
 - exposed to rain, water drops or direct sunlight.
 - high temperature or humidity, heavy dust or corrosive gas.
 - affected by external noise, radio waves or static electricity
 - where there is constant vibration or shock.
- Do not use this meter with the case open or with modification.

1.1 ● Preparation prior to use

1.1.1 Inspection

When the meter is delivered, check whether it conforms to the ordered specifications and hasn't been damaged during shipping.

If there is any damage or does not operate as per the specifications, inform us the model name and the serial number of the meter.

1.1.2 Storage

When the meter is not in use for a long time, store it in the place where the humidity is low and the meter is not exposed to the direct sunlight.

1.2●Confirmations prior to use

1.2.1 Power supply

Use this meter with the power supply voltage within AC90~250V and frequency 50/60Hz.
Also, ensure that the power switch is turned OFF when connecting the power supply cord.

1.2.2 Power supply cable

Power supply cable plug attached to this meter is for the AC100V. In case the supply voltage exceeds AC125V, use the appropriate supply voltage cable that matches the rating.

Make a connection of power supply cable to the power supply connector on the rear panel of the meter.

The plug has 3 pins and the round shaped pin at the center is for earthing.

When the connection is made with the use of the adaptor that comes with the plug, ensure to connect the earth lead coming out from the adaptor to the external earth terminal for grounding.

1.2.3 Replacement of fuse

A power supply fuse 250V/2A is mounted when the meter is delivered from the factory.

The fuse socket of this meter is common with the connector for input of power source line.

Before connecting the power cord, take off a cap of fuse socket and confirm the rated value of fuse. Two fuses including a spare are stored inside the cap.

① Remove the fuse socket.

In the inlet center, the flathead screwdriver etc. is placed on the projection of the fuse-socket and pulled out.

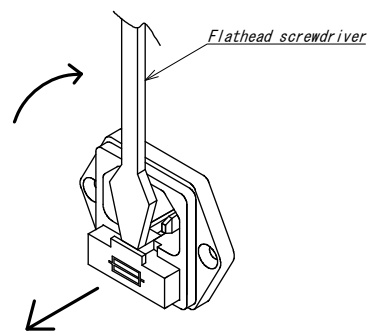

② Insert the fuse into the fuse socket paying attention to the mounting position.

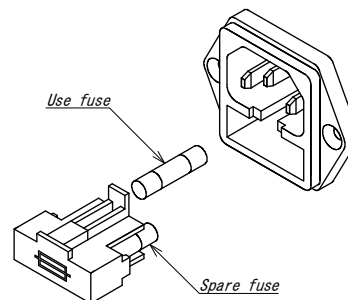

③ Mount the fuse socket ensuring that the fuse has been inserted in the correct position.

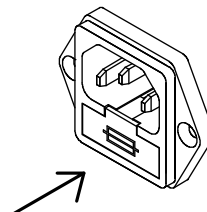

1.3●Warning and caution of measurement time

1.3.1 Electric shock or failure

|  Warning |
|--|
| <ul style="list-style-type: none">●In order to prevent the electric shock accident or the failure of this unit, don't apply voltage to the measurement terminal.●In order to prevent the failure, conduct the measurement after turning off the power related to the measurement.●During the state when the motor is rotating, a large electromotive force is generated in the terminal and this may be the cause for the electric shock accident or the failure of this unit. |

1.3.2 Measurement of transformer and coil

|  Caution |
|--|
| <ul style="list-style-type: none">●Do not use 1A measurement current for the range of 30mΩ, 300mΩ measurement range for the thing with inductance more than about 5H and resistance below 3Ω of transformer and coil. There is a risk to damage this unit. |

2. Name of parts

2.1●Front panel

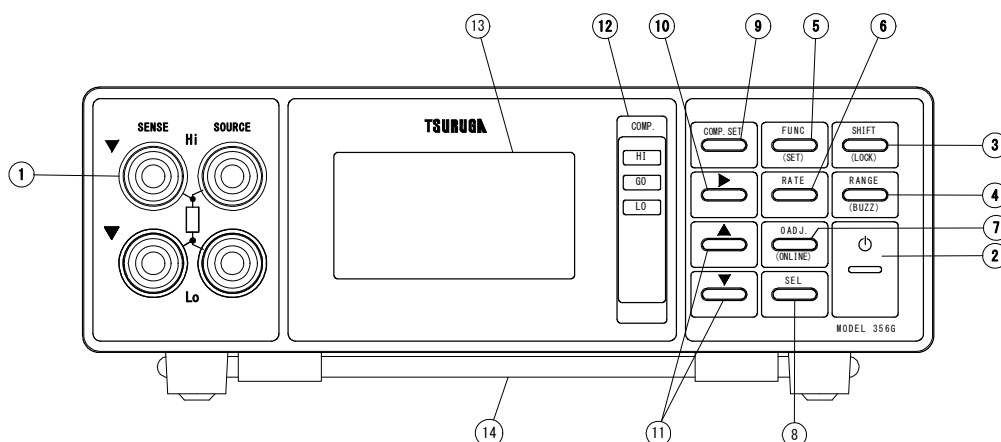

| | |
|---------------------------------|--|
| ① Measuring terminals | SENSE Hi : + side terminal of voltage input. SENSE Lo : - side terminal of voltage input. SOURCE Hi : + side terminal of current output. SOURCE Lo : - side terminal of current output. |
| ② Power lamp | LED is lit up when power is on. |
| ③ SHIFT key (LOCK) | Press when the function that is marked with orange color () is used. It is cancelled if the key is pressed again. SHIFT mark is displayed when functioning. (The switch of the front panel is operation prohibition switch. If it is pressed for more than 3 seconds, it can be prohibited or release prohibition. During the prohibition, LOCK is displayed on the upper side of LCD.) |
| ④ RANGE key (BUZZ) | Key to select range 30mΩ~300Ω or AUTO range. (Key to select buzzer operation and volume setting.) |
| ⑤ FUNC key (SET) | Key to select measurement function. (Performs various settings.) |
| ⑥ RATE key | Key to select the sampling rate. |
| ⑦ 0 ADJ. key (ONLINE) | Key for ON/OFF of zero adjustment function. |
| ⑧ SEL key | Key to select memory no. |
| ⑨ COMP.SET key | Key to perform the setting of the comparator. |
| ⑩ ▶ key | Used for comparator and various settings. |
| ⑪ ▲ ▼ key | Used for comparator and various settings. |
| ⑫ HI GO LO | Red LED is lit up when the measured value is higher than upper limit. Green LED is lit up when good judgment. Red LED is lit up when the measured value is less than lower limit. |
| ⑬ Display window | Measurement function, measurement range, measurement value, comparator settings, memory no. etc. are done. |
| ⑭ Stand | When the stand is pulled in front to be erect, the meter can be tilted. Do not apply strong force from above when the meter is tilted. |

Note () Key is enabled when SHIFT is being displayed.

LCD Display window

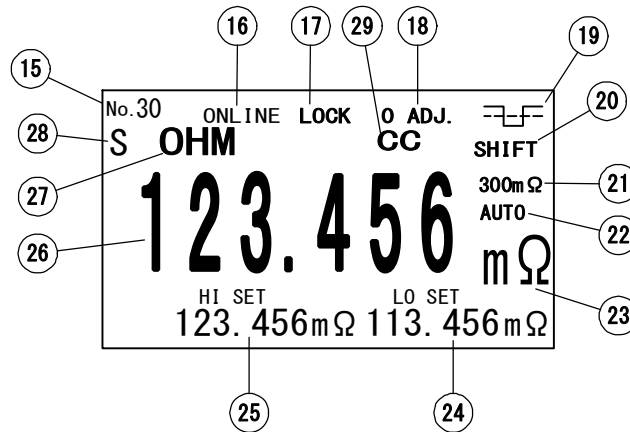

| | |
|--|---|
| ⑮ No. display | Displays Memory no. |
| ⑯ ONLINE EXT. | Displays [ONLINE] when setting can be done by USB, RS-232C, RS-485. Displays [EXT.] when memory no. is selected by external control. |
| ⑰ LOCK | Displays when key locked. |
| ⑱ 0 ADJ. | Displays during zero adjustment function. |
| ⑲ $\overline{\text{---}}$ | Displays at the time of measurement by the offset voltage correction function. |
| ⑳ SHIFT | It works with the linkage with SHIFT key. Displays when SHIFT key is enabled. |
| ㉑ Resistance range | Displays the measured range from 30mΩ to 300Ω. |
| ㉒ AUTO | Displays at the time of auto range. |
| ㉓ Unit | Displays the unit of measurement value. |
| ㉔ LO SET display window | Displays the lower limit of the comparator. |
| ㉕ HI SET display window | Displays the upper limit of the comparator. |
| ㉖ Measurement location display window | Displays measurement value and characters. |
| ㉗ Function | Displays measurement function. |
| ㉘ F M S | [F] is lit up when the sampling rate is 80 times/sec. [M] is lit up when the sampling rate is 20 times/sec. [S] is lit up when the sampling rate is 5 times/sec. Displays and lit under HOLD operation and during sampling stop under setting, |
| ㉙ CC | Displays [CC] at the time of SOURCE open detection. (There is a case of [CC] being displayed when a large resistance is connected with respect to the measurement range.) |

2.2●Rear panel

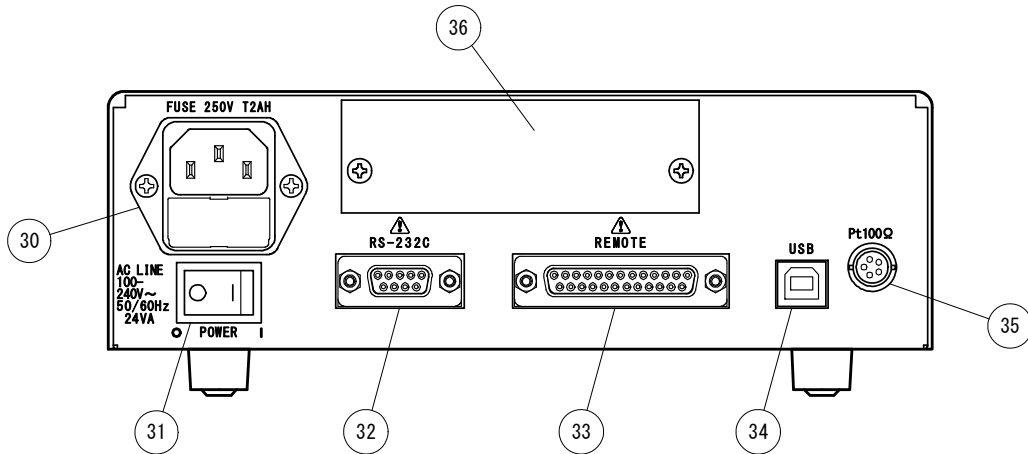

| | |
|--------------------------------|---|
| ⑩ Power inlet | Connect the power supply cord. Ensure to use the power voltage and frequency within the specified range. Fuse of 250V T2AH is to be used. |
| ⑪ Power switch | ON/OFF switch for power supply |
| ⑫ RS-232C connector | RS-232C interface connector. |
| ⑬ REMOTE connector | Connector for external control. |
| ⑭ USB connector | USB interface connector. |
| ⑮ Temperature sensor connector | Pt100Ω temperature sensor connector. When using temperature correction function, connect the temperature sensor (5803-11) which is optional. |
| ⑯ Option interface | In case of BCD output and equipped with RS-485, the interfaces implemented. |

3. Function and method of operation

3.1●Power supply

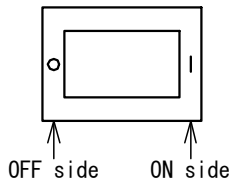

After confirming that the power supply switch on the rear panel is OFF, connect the power supply plug to the connector and turn ON the power supply switch.

When power supply switch is ON, power supply lamp of front panel is lit.

Take more than 30 minutes for pre-heating.

Besides, as it is equipped with function to retain the parameters, the following states are memorized even when the power is OFF.

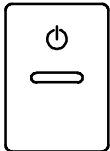

- (1) Measurement range
- (2) Measurement function
- (3) Sampling setting
- (4) Set values of comparator
- (5) Status of key lock
- (6) Status of buzzer
- (7) Contents of various settings

3.2●Connection of measuring terminals

3.2.1 Connection of resistance measurement terminals

Make a connection to the measuring terminals on the front panel as shown in the figure below.

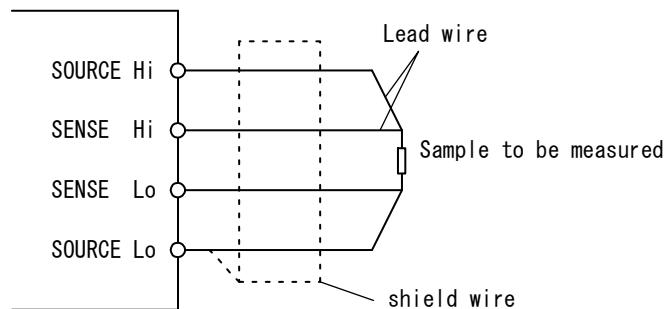

Note: Penetration of noise to the measuring terminals may cause disturbing display or instability in auto range operation. Prevent the noise by using shield wire and connecting shield side to SOURCE Lo.

Carry out the plugging of the Kelvin clips (banana plug side) and the resistance meter as follows.

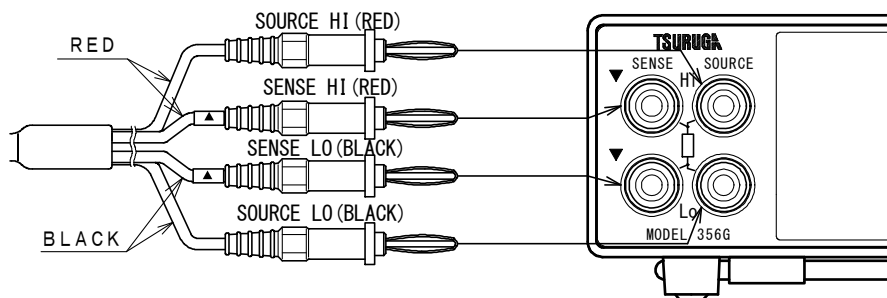

Connection of Kelvin clip (MODEL5811-21B)

3.2.2 Connection of temperature measurement terminals

Temperature sensor is connected during temperature measurement (TEMP) and temperature correction (T.C. and T.C. RATIO).

Temperature sensor is connected to temperature sensor connector of rear panel.

Temperature sensor: 5803-11

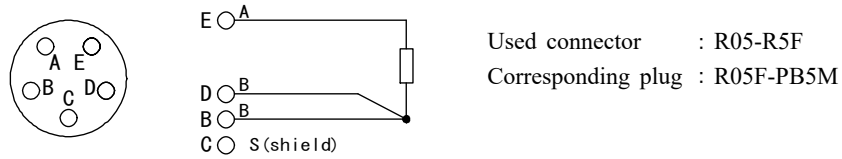

3.3●Key lock

This is the switch to prohibit the key operation on the front panel so that the measuring status cannot be unintentionally altered.

LOCK mark is displayed in the upper side of LCD during the key lock. During key lock, in order to operate other switches do it after releasing the key lock.

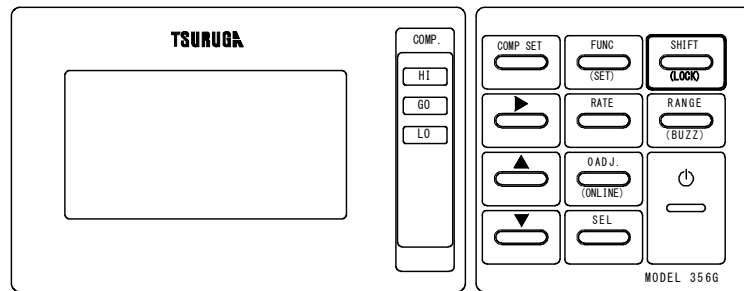

Method of Key lock

Key lock takes place when **SHIFT (LOCK)** key is pressed for more than 3 seconds. LOCK mark is displayed in the upper side of LCD.

Release of Key lock

Key lock is released when **SHIFT (LOCK)** key is pressed for more than 3 seconds once more.

3.4●Selection of measurement function

Measurement function is selected.

Note: During key lock, HOLD status, ONLINE and external control (EXT. display) status, operation cannot be done.

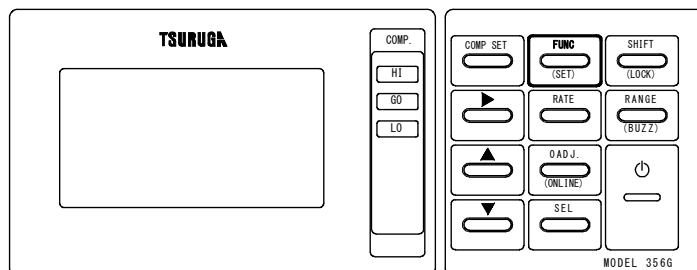

| Function | Display | Measurement | Unit |
|--------------------------------------|-----------|--|---------------------|
| Resistance measurement | OHM | Resistance is measured and resistance value is displayed. | Ω m Ω |
| Temperature measurement | TEMP | Temperature is measured and displayed. | $^{\circ}\text{C}$ |
| Temperature correction | T.C | Resistance is measured and temperature correction value is displayed. | Ω m Ω |
| Ratio display | OHM RATIO | Resistance is measured and ratio computed value corresponding to standard value is displayed. | % |
| Temperature correction ratio display | T.C RATIO | Resistance is measured and temperature correction is done. The ratio computed value corresponding to temperature value is displayed. | % |

Change-over of function

When **FUNC** key is pressed, the function is changed-over and the function display of LCD is changed over.

It is changed-over in the order of OHM→TEMP→T.C→T.C RATIO→OHM RATIO.

3.4.1 Resistance display (OHM)

Resistance measurement value is displayed.

Display screen at the time of resistance display

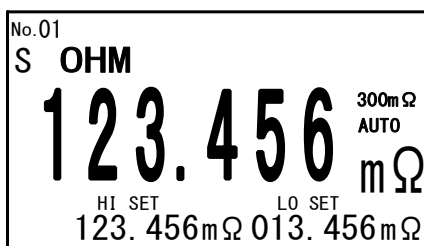

3.4.3 Ratio display function (OHM RATIO)

It is a function displayed in percentage with respect to standard resistance value by comparing measured resistance value Rx and standard resistance value Rs.

The comparison judgment ($\pm\Delta\%$) of deviation can be done.

Formula:

$$X = \frac{R_x}{R_s} \times 100\%$$

$$\Delta = \left(\frac{R_x}{R_s} - 1 \right) \times 100\%$$

X : Ratio (%)
 Rs : Standard resistance (Ω)
 Rx : Measured resistance value (Ω)
 Δ : Deviation (%)

Display range -199.9~199.9%

OVER is displayed when it exceeds the display range.

$\pm\Delta\%$ Comparison operation (Setting range : 0 ~100.0%)

Standard resistance value Rs (Setting range : -199999 ~ 350000)

Display screen at the time of ratio display function

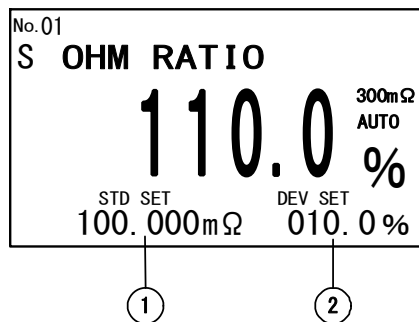

①Standard resistance value (Rs)

②Comparison range $\Delta\%$

When comparison range $\Delta\%$ is set to 10.0%, $\pm 10\%$ of the range corresponding to 100% is made GO judgment.

- LO judgment : -199.9~89.9%, -OVER
- GO judgment : 90.0~110.0%
- HI judgment : 110.1%~199.9%, OVER

Refer to 3.8.3 Comparator setting method for setting of standard resistance value and comparison range.

3.4.4 Temperature correction ratio display function (T.C RATIO)

It is a function displayed in percentage with respect to standard resistance value by comparing resistance value Rx computed by temperature correction (T.C) and standard resistance value Rs.

Refer to 3.4.3 Ratio display function for calculation formula and comparison function.

Display screen at the time of temperature correction ratio display function

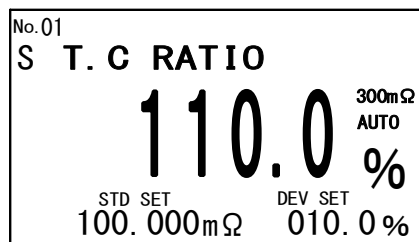

3.4.5 Temperature display (TEMP)

The temperature measured by temperature sensor is displayed.

In temperature measurement, the sampling rate is fixed by [S] and cannot be changed.

In temperature measurement, comparison operation is not performed.

Display screen at the time of temperature display

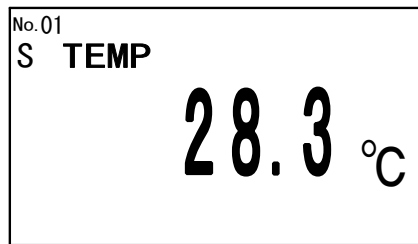

3.4.6 Measurement disorder detection

When over of the measurement and open of the SOURCE terminal is detected and displayed, signal in the remote control is output together.

| Status | Display | | Remote connector output signal | | |
|------------------------------|---------------------------|------------|--------------------------------|-------|-------|
| | Measurement display | CC display | ERR-CC | ERR 0 | ERR 1 |
| Normal | Display measurement value | OFF | OFF | OFF | OFF |
| SOURCE Open | Display measurement value | ON *1 | ON *1 | OFF | OFF |
| Resistance measurement over | OVER/-OVER | OFF | OFF | ON | OFF |
| Temperature measurement over | OVER/-OVER | OFF | OFF | OFF | ON |

*1: When resistance exceeding the measurement range is connected, there is a case where SOURCE is open.

3.5●Change-over of measuring range

Select a measuring range (auto range or manual range) of resistance measurement.

During key lock, HOLD status, ONLINE and external control (EXT. display) status, operation cannot be done.

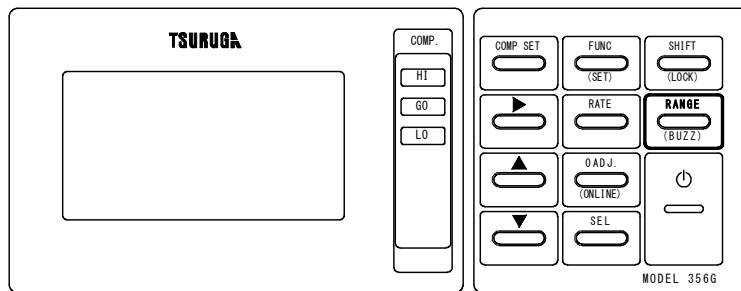

(1) Auto range

The measurement range steps up when display value is above 350000 and steps down when the display value is below 30000.

(During FAST sampling, steps up when above 35000 and steps down when below 3000)

AUTO mark and resistance range is displayed in right side of LCD.

Selection of AUTO range

When the **RANGE** key is pressed at 300Ω range, AUTO mark is displayed in the right side of LCD and the meter enters the auto ranging.

(2) Manual range

The range is fixed at 30mΩ~300Ω.

It is measured by the selected range.

Change-over of range

Range mark (30mΩ~300Ω, AUTO) in the right side of LCD is changed-over when the **RANGE** key is pressed.

3.6●Selection of the sampling rate

Select the sampling rate with the key operation of front panel of this meter.

During key lock, HOLD status, ONLINE and external control (EXT. display) status, operation cannot be done.

Note: Sampling cycle cannot be changed with temperature measurement (TEMP).

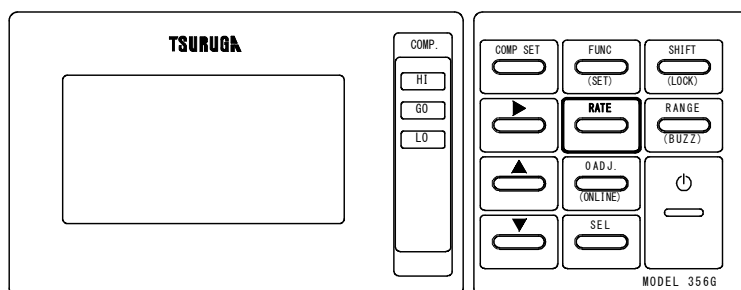

Sampling rate is changed-over when **RATE** key is pressed.

S→M→F→S...

S display : 5 times/sec

M display : 20 times/sec

F display : 80 times/sec

3.7•Zero adjustment

This is the function to eliminate resistance of tools etc. with resistance measurement.

The data being measured presently is recorded in memory as zero set value and regarding the measurement afterwards, the zero set value subtracted from measurement value is displayed.

$$\boxed{\text{Display value}} = \boxed{\text{Measured value}} - \boxed{\text{Zero set value}}$$

Note: It does not perform zero adjustment for temperature measurement (TEMP).

Zero set value operates in all ranges.

When zero adjustment is done in the upper range, it may be over in the lower range.

3.7.1 Key operation

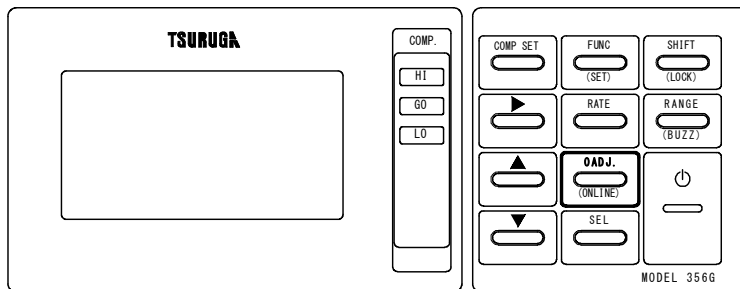

When **0 ADJ.** key is pressed, it will be the operating status of zero adjustment.

0 ADJ. mark is displayed in the upper side of LCD during zero adjustment.

Zero adjustment is released when **0 ADJ.** key is pressed once more.

Note: During key lock, HOLD status, ONLINE and external control (EXT.) status, operation cannot be done.

3.7.2 Remote operation

When 0 ADJ input of rear panel REMOTE connector is ON, it is in the zero adjustment function status.

When turned OFF, operation is released.

Note: When this input is turned OFF, the zero adjustment function set by the key operation is released.

3.7.3 Communication operation

With the direction of USB, RS-232C and RS-485, the operation of ON/OFF of zero adjustment is possible.

Communication operation is performed in the ONLINE status.

3.7.4 Zero adjustment operation priority order

| Operation | Priority order |
|----------------------------------|----------------|
| Remote operation | ↑ High Low |
| Communication operation (ONLINE) | |
| Key operation | |

3.8●Comparator

This is a digital comparator to make a comparison between displayed value and high or low limit value.

Note: It does not perform comparator operation for temperature measurement (TEMP).

During the setting of high or low limit value, sampling is stopped and comparison output is held.

During key lock, HOLD status, ONLINE and external control (EXT. display) status, operation cannot be done.

At the time of ration calculation, high and low comparator becomes standard resistance and deviation.

3.8.1 Conditions for comparison

Display value \geq High limit value (HI SET) HI output

High limit setting value (HI SET) > display value > Low limit setting value (LO SET) GO output

Display value \leq Low limit setting value (LO SET) LO output

Note: Comparator makes comparison including range.

Example) In case that the high limit value is set to 100.000m Ω ,

HI is output when 10.000 Ω is displayed in the range of 30 Ω range.

3.8.2 Comparator output

Open collector output is output through REMOTE connector on the rear panel.

Judgment display . . . HI, LO : Red

GO : Green

3.8.3 Setting method

Setting cannot be done during ONLINE, EXT. and HOLD.

Adjustable range High limit : -199999~350000

Low limit : -199999~350000

The unit and decimal point are set by **RANGE** key.

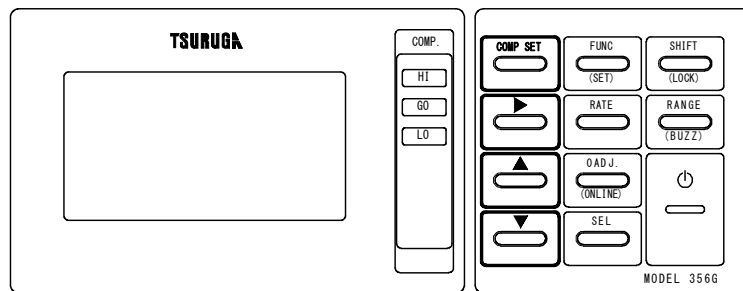

Setting of high limit (Standard resistance Rs)

① Press **COMP SET** key.

The cursor is moved to the highest digit of HI SET upper limit on the lower side of LCD.

Cursor is moved and the character selected is inverted with **▶** key

The number of digits selected is set with **▲** **▼** key.

Setting of lower limit (comparison range $\Delta\%$)

② Press **COMP.SET** key.

The cursor is moved to the highest digit of LO SET lower limit on the lower side of LCD.

Cursor is moved and the character is inverted with **▶** key.

The number of digits selected is set with **▲** **▼** key.

Setting of comparator range

③ Select the decimal point position and unit with **RANGE** key.

End of setting

④ Press **COMP.SET** key.

3.9●Buzzer

Setting of buzzer is done with (BUZZ) key on the front panel.

During the setting of buzzer, the sampling is stopped and the comparator output is held.

Note: During key lock, HOLD status, ONLINE and external control (EXT. display) status, operation cannot be done.

3.9.1 Setting method

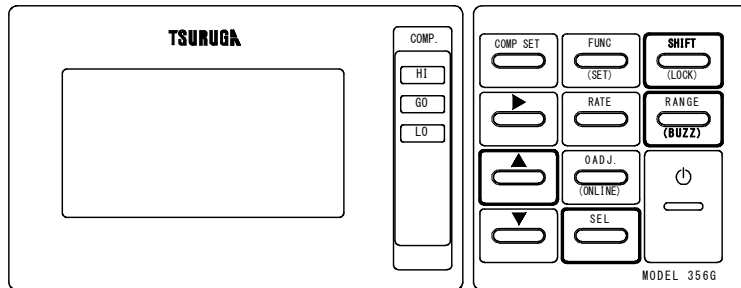

Setting of buzzer

- ① Press **SHIFT** key.
SHIFT is displayed on the right side of LCD.
- ② Press RANGE(BUZZ)key.
LCD will switch to the setting screen.

Selection of buzzer operation

- ③ Buzzer operation is selected with **▲** key.

| Display | Operation |
|---------|--|
| GOOD | Buzzer sounds during GO judgment. |
| HI NG | Buzzer sounds during HI judgment. |
| LO NG | Buzzer sounds during LO judgment. |
| NG | Buzzer sounds during HI and LO judgment. |
| OFF | Buzzer is turned OFF. |

Adjustment of sound volume

- ④ Press **SEL** key.
Buzzer sounds.
Adjust to a proper sound volume with **▲** key.
The volume is adjustable in 10 steps.

End

- ⑤ Press **SHIFT** key.
SHIFT is displayed on the right side of LCD.
- ⑥ Press RANGE (BUZZ) key.

3.10●Average calculation

Average function averages the measurement and displays the outputs.

You can reduce variations in the display by setting the average count.

The average count can be set between 1 and 100 times.

Note: Temperature measurement (TEMP) does not perform average calculation.

During the setting, the sampling is stopped and comparator output is held.

During key lock, HOLD status, ONLINE and external control (EXT. display) status, operation cannot be done.

3.10.1 Setting method

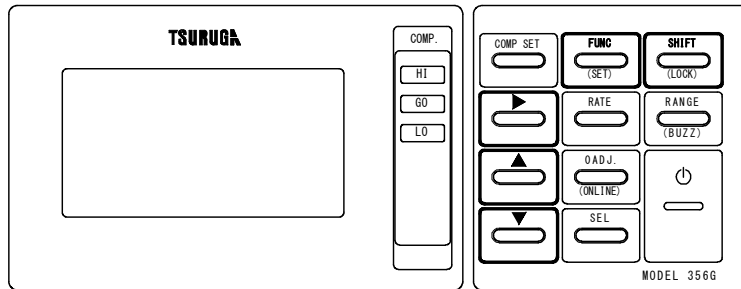

Setting after moving to setting screen

- ① Press **SHIFT** key.

SHIFT is displayed on the right side of LCD.

- ② Press **FUNC (SET)** key.

LCD is switched to 「SETUP」 screen and 「MEAS SET」 becomes selected state.

When 「MEAS SET」 is not in selected state, selection is done by [▼] key.

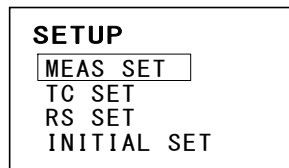

- ③ When [▶] key is pressed during 「MEAS SET」 selection status, it switches to 「MEAS SET」 screen and becomes in the state of 「AVE」 of highest digit.

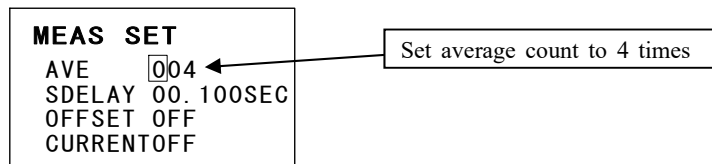

Average count is set with 「AVE」.

The digit is changed with [▶] and setting value is changed with [▼][▲] key.

End

- ⑤ Press **SHIFT** key.

SHIFT is displayed on the right side of LCD.

- ⑥ Press **FUNC(SET)** key.

3.10.2 Operation of the average calculation

| Status | Operation |
|--|---|
| Continuous sampling state | Moving average |
| Sample once by TRG signal during HOLD | After average number of sampling, the average value is displayed and HOLD. |
| Sample once by communication with READ command during HOLD | |
| Sample once by releasing HOLD for short time during HOLD | Display measuring value by first sampling and HOLD. |
| Continuous sampling with release of HOLD status | Display the measurement value by first sampling and displays average value till average setting factor after second sampling. |

① Start sampling by TRG signal or READ command during HOLD

Average count: Set to 3times

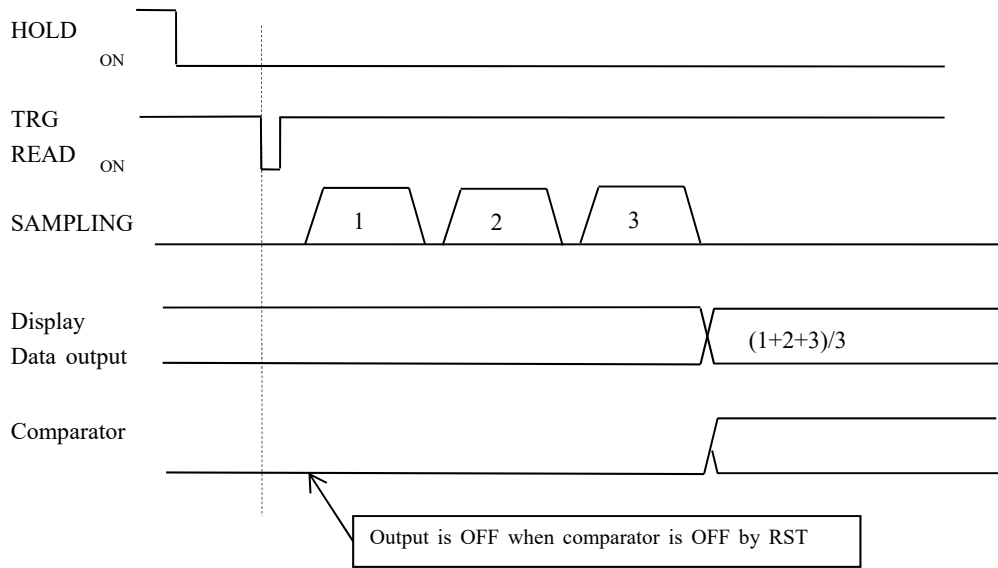

② Start sampling with release of HOLD

Average count: Set to 3 times

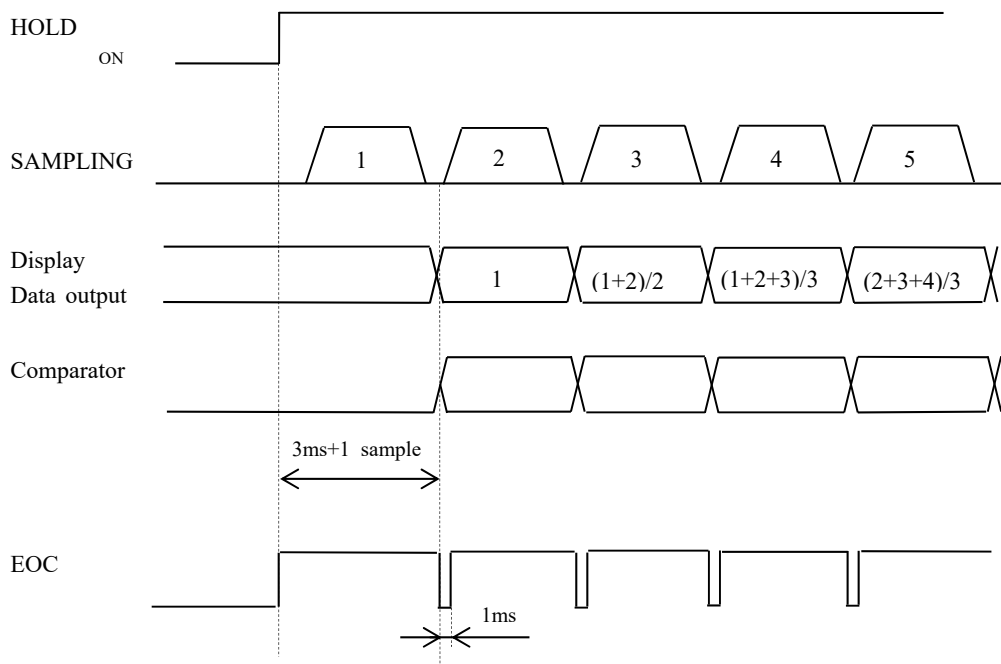

3.11●Offset voltage correction function

Thermoelectromotive force or internal offset voltage of this meter is corrected.

The result computed from the calculation formula is displayed as below from the measurement value (Rp) of the current flowing in the positive direction and the measurement value (Rr) of the current flowing in the reverse direction.

$$\frac{Rp - Rr}{2} \quad \text{Thermoelectromotive force acceptable range} \cdots \text{Less than 1mV}$$

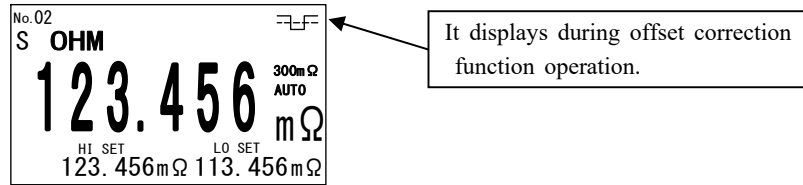

If the measured target is capacitive, it might take a long time for the switching response of the current.

In such a case, it is possible to set the delay time with start delay time.

Set the delay time aimed to be ten times the calculation formula as shown below so that the inductance is not affected.

$$t = - \frac{L}{R} \ln \left(1 - \frac{IR}{Vo} \right)$$

L : Inductance of the sample

R : Resistance of the sample + lead resistance + contact resistance

I : Measured current

Vo : Open voltage (6V)

Even when the sample is a pure resistance, it is important to have 1ms~10ms of delay time.

Note: When zero adjustment is used, after setting of the offset voltage correction, re-set the zero adjustment.

When offset voltage correction function is enabled, the sampling time becomes about two times longer.

3.11.1 Setting method

During key lock, HOLD status, ONLINE and external control (EXT. display) status, operation cannot be done.

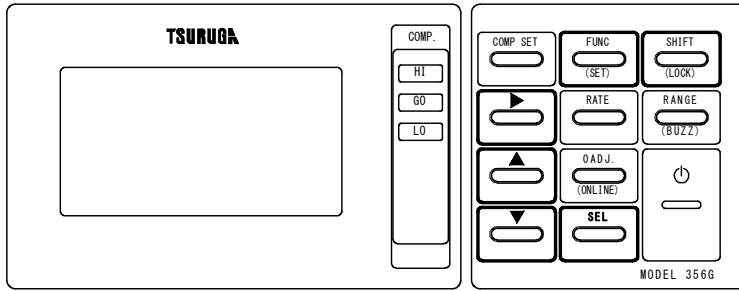

Setting after moving to setting screen

- ① Press **SHIFT** key.
SHIFT is displayed on the right side of LCD.
- ② Press **FUNC(SET)** key.
LCD switches to 「SETUP」 screen and 「MEAS SET」 becomes selection status.
When 「MEAS SET」 is not in the selection status, selection is done with [▼] key.

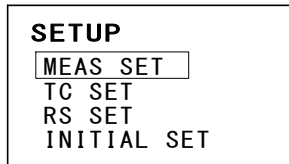

- ③ When [▶] key is pressed during 「MEAS SET」 selection status, it switches to 「MEAS SET」 screen and becomes in the state of 「AVE」 of highest digit.

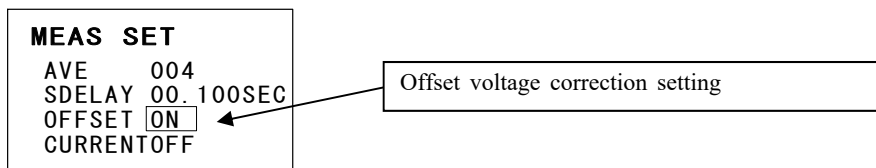

- ④ Offset voltage correction is set by selecting 「OFFSET」 with [SEL] key.
Set ON/OFF with [▼][▲] key.
ON : Offset voltage correction function is enabled.
OFF: Offset voltage correction function is disabled.

End

- ⑤ Press **SHIFT** key.
SHIFT is displayed on the right side of LCD.
- ⑥ Press **FUNC(SET)** key.
Setting is memorized and returns to the measurement display.

3.12●Start delay

The setting of delay time until the start of measurement during HOLD, TRG signal and start time with READ communication command is possible.

After the connection with the sample, even when started, it is possible to do the stable measurement.

Setting range 0ms~10.000s (10 sec)
 Accuracy Within ±1% of setting value

Timing chart

- Average count 1time
- Offset voltage correction function OFF

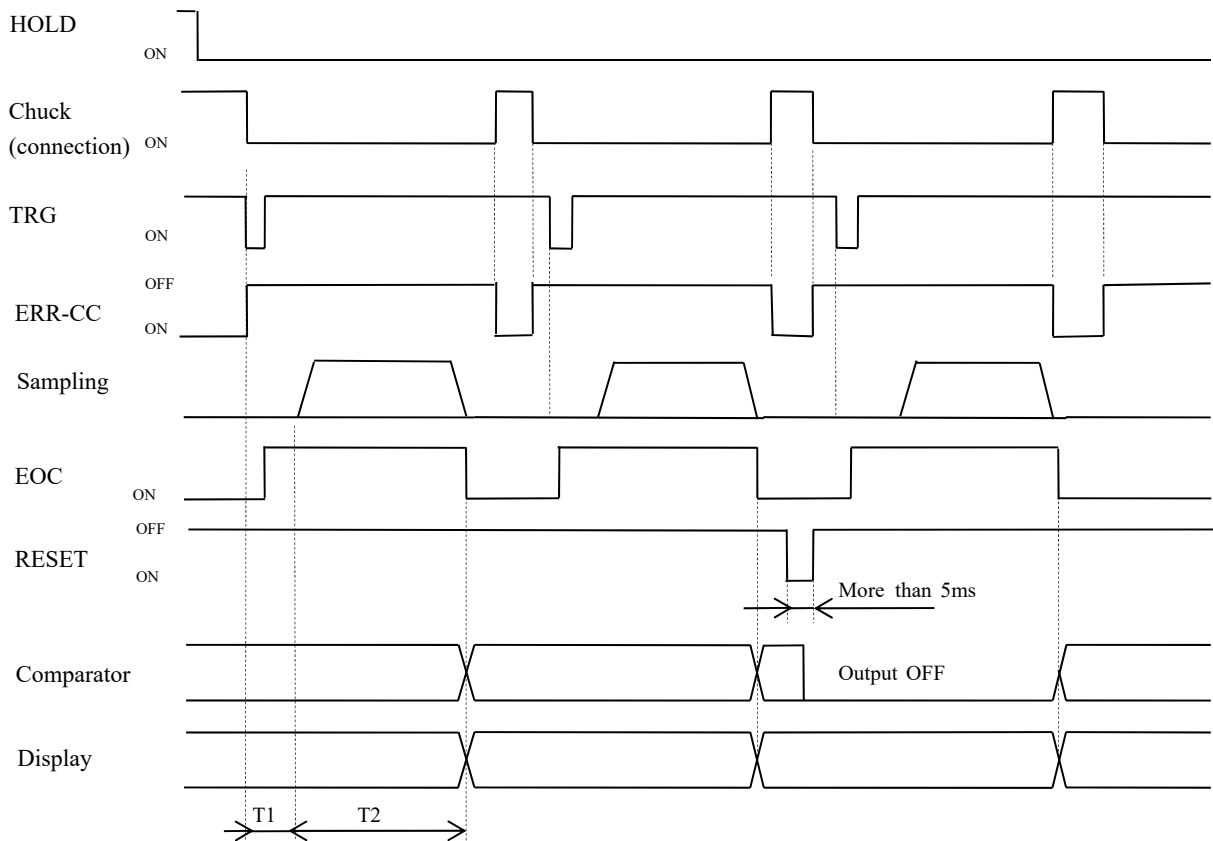

T : Response time
 $T=T_1+T_2$
 T1 : Start delay
 T2 : Measurement time (Measurement+ Processing time)
 T1+T2 : Response time

T1 Processing time

Offset voltage correction function OFF

Average count $\times 0.1\text{ms}+3\text{ms}$

Offset voltage correction function ON

Average count $\times 0.1\text{ms}+6\text{ms}$

When the range is changed during HOLD, 15ms of range switching time will be added.

3.12.1 Setting method

During key lock, HOLD status, ONLINE and external control (EXT. display) status, operation cannot be done.

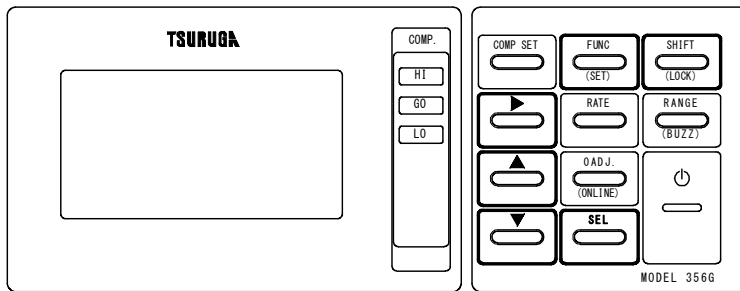

Setting after moving to setting screen

- ① Press **SHIFT** key.
SHIFT is displayed on the right side of LCD.
- ② Press **FUNC (SET)** key.
LCD switches to 「SETUP」 screen and 「MEAS SET」 becomes selection status.
When 「MEAS SET」 is not in selection status, selection is done with [▼] key.

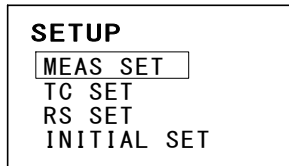

- ③ When [▶] key is pressed during 「MEAS SET」 selection status, it switches to 「MEAS SET」 screen and becomes in the selected state of 「AVE」 of highest digit.

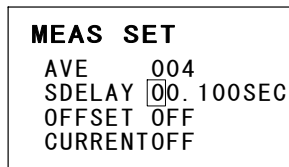

Start delay is set to 0.1 sec.

- ④ 「SDELAY」 is selected with [SEL] key and start delay is set.
Digit is changed with [▶] key and setting value is changed with [▼] [▲] key.
There is no start delay in case the setting is 0.000sec.

End

- ⑤ Press **SHIFT** key.
SHIFT is displayed on the right side of LCD.
- ⑥ Press **FUNC (SET)** key
The setting is memorized and it returns to measurement display.

3.13●Measured current limit function

It is a function to turn off the measured current (SOURCE) during sampling HOLD.

If the measured object is inductive, during probe connection, resonance phenomenon is occurred and the measurement is not stable and there is a case when stress is added to the resistance meter where overvoltage is applied due to the counter electromotive force. By using the measured current limit function, it is possible to reduce the resonance phenomenon and back electromotive force.

Timing chart

- Average count 1 time
- Offset voltage correction function OFF

[During release of HOLD]

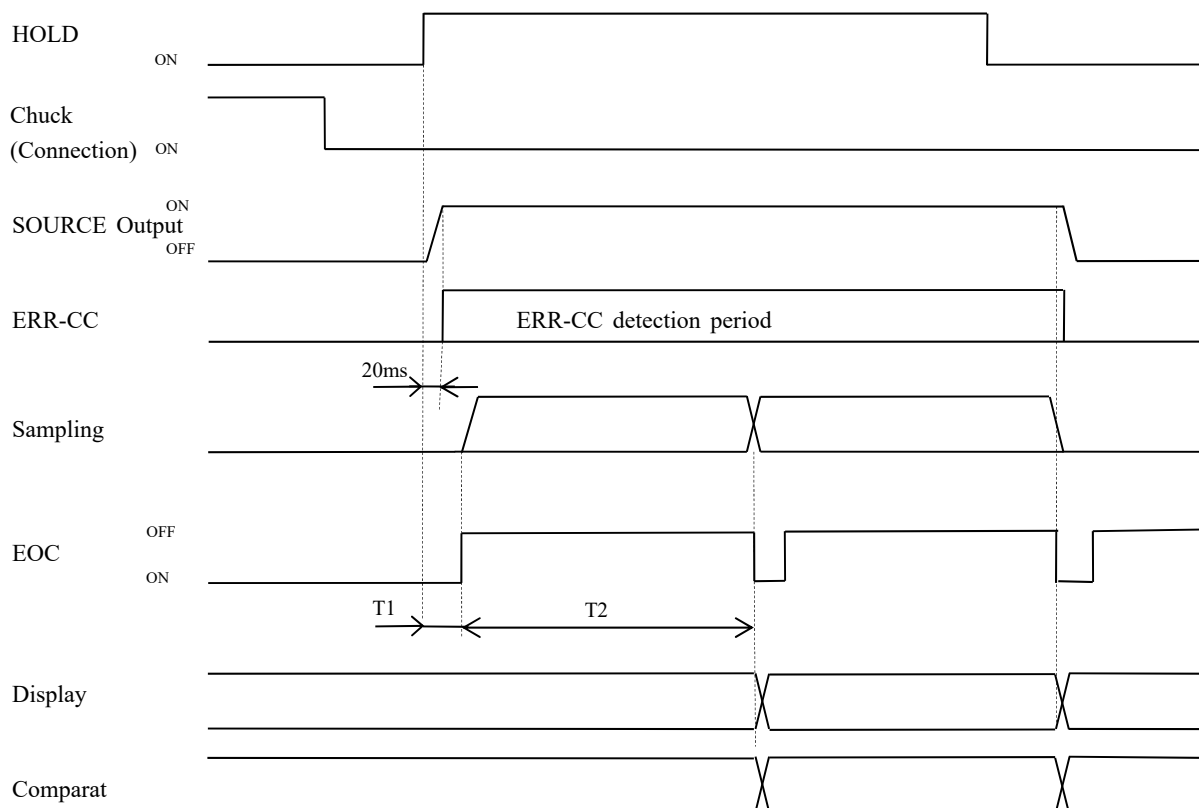

T1 : 50ms + Start delay time

When the range is changed during HOLD, 15ms of range switching time will be added.

T2 : Sampling time + processing time

[Sampling with TRG or READ during HOLD]

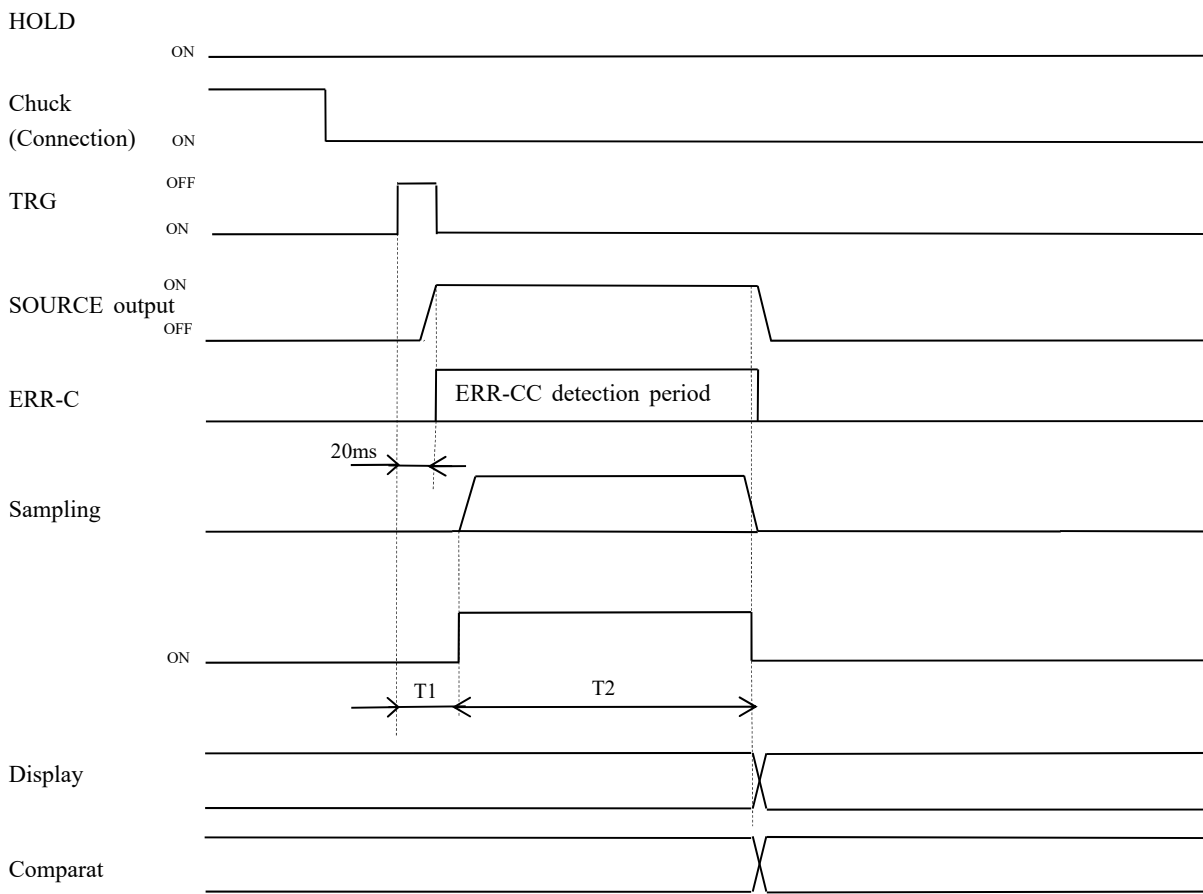

T1 : 50ms + Start delay time
 When the range is changed during HOLD, 15ms of range switching time will be added.
 T2 : Sampling time + processing time

3.13.1 Setting method

During key lock, HOLD status, ONLINE and external control (EXT. display) status, the operation cannot be done.

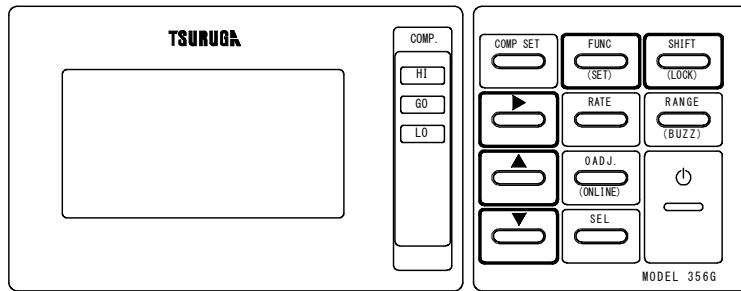

Setting after moving to setting screen

- ① Press **SHIFT** key.
SHIFT is displayed on the right side of LCD.
- ② Press FUNC (SET) key
LCD switches to 「SETUP」 screen and 「MEAS SET」 becomes selection status.
When 「MEAS SET」 is not in selection status, selection is done by [▼] key.

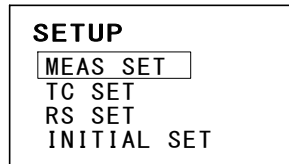

- ③ When [▶] key is pressed during 「MEAS SET」 selection status, it switches to 「MEAS SET」 screen and becomes in the selected state of 「AVE」 of highest digit.

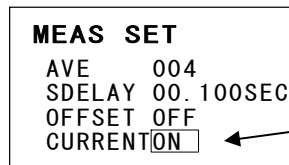

Measured current limit function setting

- ④ Measured current limit function is set by selecting 「CURRENT」 with [SEL] key.
Setting value is changed with [▼] [▲] key.

End

- ⑤ Press **SHIFT** key.
SHIFT is displayed on the right side of LCD.
- ⑥ Press FUNC (SET) key.
The setting is memorized and returns to the measurement display.

3.14●Program memory

This meter is equipped with 30 sets of program memory which memorizes measurement function, range, comparator setting.

It is possible to select the memory with key operation, signal and communication of REMOTE connector.

3.14.1 Selection of program memory

During key lock, HOLD status, ONLINE and external control (EXT. display) status, the operation cannot be done.

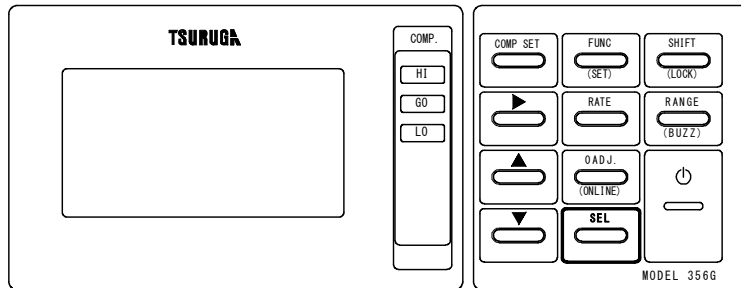

Selection of program memory

Program memory no. is displayed on the left side of LCD.

When [SEL] key is pressed, memory no. changes and it switches to the setting being memorized in memory.

3.14.2 Registration of program memory

Set the measurement function, measurement range and upper and lower limit comparator after the selection of registered memory no. (During ratio calculation, upper and lower comparator becomes standard resistance and the deviation)

3.15•Temperature correction function

The conductor resistance and ambient temperature are measured and the measured conductor resistance is displayed in terms of the standard value.

The standard temperature can be set to 0.0~99.9°C and the temperature coefficient can be set to the range of 1000~9999ppm. Measurement of ambient temperature is done by connecting Pt100Ω temperature sensor.

Calculation formula:
$$R_T = \frac{R_t}{1+(\alpha \times 10^{-6}) \times (t-T)} \quad (\Omega)$$

t : Ambient temperature(°C)

R_T : Correction resistance(Ω)

R_t : Resistance value(Ω) at the ambient temperature

α : Temperature coefficient ... Setting range 1000~9999ppm

T : Standard temperature ... Setting range 0.0~99.9°C

Accuracy during temperature correction function: Addition of ±0.3% of rdg. to accuracy of resistance measurement.

Calculation range : Maximum 399999

When the calculation result exceeds 399999, it becomes OVER display.

3.15.1 Setting method

During key lock, HOLD status, ONLINE and external control (EXT. display) status, the operation cannot be done.

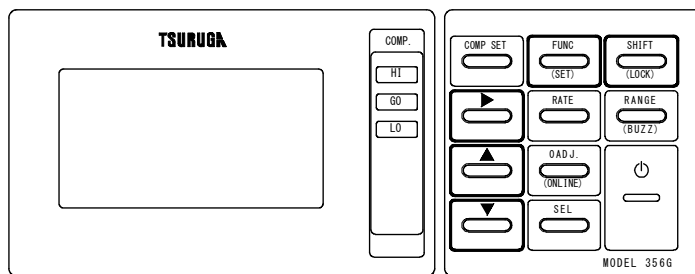

Setting after moving to setting screen

① Press **SHIFT** key.

SHIFT is displayed on the right side of LCD.

② Press **FUNC(SET)** key.

LCD switches to 「SETUP」 screen and 「MEAS SET」 becomes selection status.

「TC SET」 is selected with **[▼]** key.

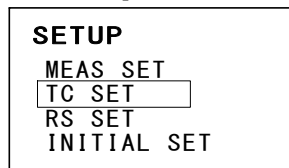

③ When **[▶]** is pressed during 「TC SET」 selection status, it switches to 「TC SET」 screen and becomes in the selected state of 「STD」 of highest digit.

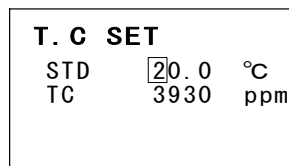

STD : Correction temperature setting

TC : Correction constant (Temperature coefficient)

④ 「STD」 and 「TC」 are selected with **[SEL]** key.

Digit is selected with **[▶]** key.

Setting value is set with **[▼]** **[▲]** key.

End

⑤ Press **SHIFT** key.

SHIFT is displayed on the right side of LCD.

⑥ Press **FUNC (SET)** key.

The setting is memorized and returns to the measurement display.

3.16●Communication setting

Communication setting of USB, RS-232C and RS-485 are performed.

| | |
|-----------------------------|---|
| Equipment number | The equipment which communicates during connection with multiple units is specified with RS-485. 01 is set in case of USB and RS-232C |
| Communication speed ,Parity | When communication is done with RS-232C and RS-485, the communication speed of the equipment that communicates and parity is matched. |

3.16.1 Setting method

During key lock, HOLD status, ONLINE and external control (EXT. display) status, the operation cannot be done.

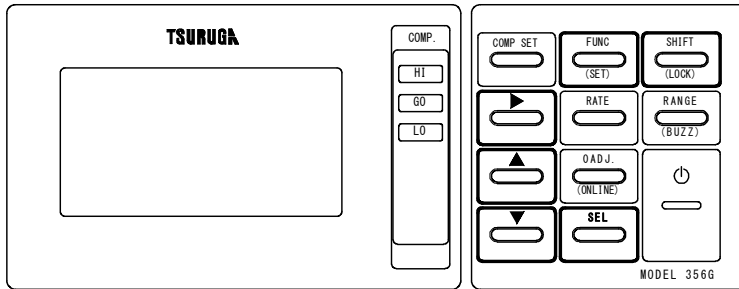

Setting after moving to setting screen

- ① Press **SHIFT** key.

SHIFT is displayed on the right side of LCD.

- ② Press **FUNC(SET)** key.

LCD switches to 「SETUP」 screen and it 「MEAS SET」 becomes selection status.

「RS SET」 is selected with [▼] key.

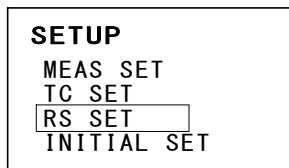

- ③ When [▶] key is pressed during 「RS SET」 selected status, it changes to 「RS SET」 and 「No.」 becomes the selected status.

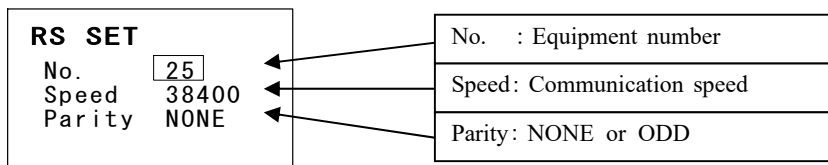

- ④ 「No.」, 「Speed」 and 「Parity」 are selected with [SEL] key.

Setting value is set with [▼][▲] key.

No. : Communication equipment number

Setting range : 00~99

Equipment number is added to the communication data.

In RS485, the equipment is identified with the connection of multi-drop.

Speed : RS-232C and RS-485 communication speed is set.

Setting range : 4800,9600,19200,38400bps

Parity : Parity of RS-232C and RS-485 are set.

Setting range : NONE, EVEN, ODD

End

- ⑤ Press **SHIFT** key.

SHIFT is displayed on the right side of LCD.

- ⑥ Press **FUNC (SET)** key.

After setting is memorized, it returns to measurement display.

3.17●Memory and initialization of setting

Program memory and various settings are returned to factory settings.

| Items | | Setting range | Default value (Factory settings) | |
|------------------------------------|---------------------|------------------------------------|-------------------------------------|------------------------------------|
| Key lock | | ON/OFF | OFF | |
| Sampling | | SLOW/MEDIUM/FAST | SLOW | |
| Zero adjustment state | | ON/OFF | OFF | |
| Zero adjustment value | | -199999~350000 | 0 | |
| Buzzer setting | | OFF/GO/HI/LO/NG | OFF | |
| Buzzer volume | | 1~10 | 5 | |
| RS232C RS-485 | Equipment no. | 00~99 | 01 | |
| | Communication speed | 4800/9600/19200/38400 (bps) | 19200 (bps) | |
| | Parity | None/Even/Odd | None | |
| Start delay | | 0.000~10.000 (sec) | 0.010 (sec) | |
| TC Temperature coefficient | | 1000~9999 (ppm) | 3930 (ppm) | |
| TC Standard temperature | | 0.0~99.9 (°C) | 20.0 (°C) | |
| Average function | | 1~100 | 1 | |
| Offset voltage correction | | ON/OFF | OFF | |
| Measurement current limit function | | ON/OFF | OFF | |
| Memory no. | | 01~30 | 01 | |
| Function | | OHM/ TEMP/ TC/ OHM-RATIO/ TC-RATIO | OHM | Setting value memory (01~30) |
| Range | | 30mΩ/ 300mΩ/ 3Ω/ 30Ω/ 300Ω/ AUTO | 3Ω | |
| Comparator H | | -199999~350000 | 300000 | |
| Comparator L | | -199999~350000 | 100000 | |
| Comparator range | | 30mΩ/ 300mΩ/ 3Ω/ 30Ω/ 300Ω | 3Ω | |
| RATIO deviation | | 0.0~100.0 | 10.0 | |
| RATIO range | | 30mΩ/ 300mΩ/ 3Ω/ 30Ω/ 300Ω | 3Ω | |
| RATIO standard resistance value | | -199999~350000 | 300000 | |

3.17.1 Setting method

During key lock, HOLD status, ONLINE and external control (EXT. display) status, the operation cannot be done.

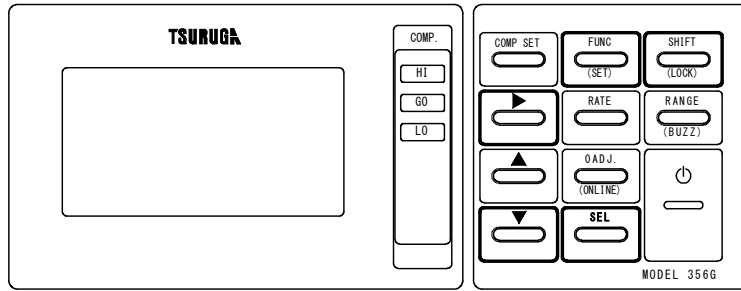

Setting after moving to setting screen

- ① Press **SHIFT** key.
SHIFT is displayed on the right side of LCD.
- ② Press **FUNC(SET)** key.
LCD switches to 「SETUP」 screen and 「MEAS SET」 becomes selection status.
「RS SET」 is selected with **▼** key.

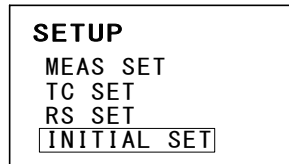

- ③ When **▶** key is pressed during 「INITIAL SET」 selection status, it switches to 「INITIAL SET」 screen.

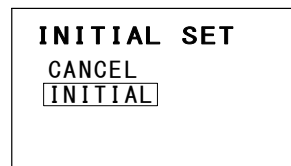

- ④ 「CANCEL」 and 「INITIAL」 can be selected with **[SEL]** key.
CANCEL : The initialization of setting value is not performed.
INITIAL : If the operation is performed after setting, the setting value is initialized.

Initialization and End

- ⑤ Press **SHIFT** key.
SHIFT is displayed on the right side of LCD.
- ⑥ Press **FUNC(SET)** key.
In case INITIAL is selected, setting memory is initialized and returns to the measurement display.
In case CANCEL is selected, it returns to the measurement display without initialization.

4. External control

4.1 Remote connector

4.1.1 Pin array

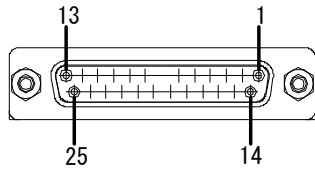

Connector use [OMRON:XM3B-2522-112]

Input circuit ("L" =Less than 1.5V "H" =3.5~5V $I_{IL} \leq -1mA$)

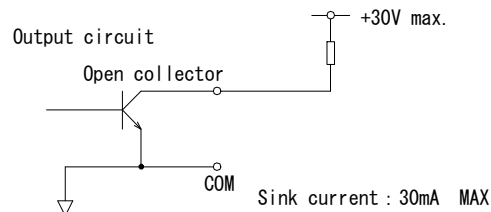
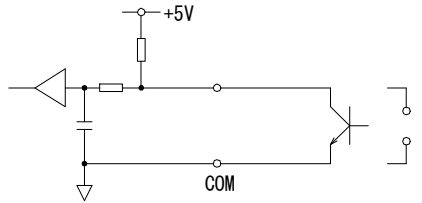

| Pin no. | Signal | | Functions |
|----------------------------|--|---------------|--|
| | Signal name | Input/ Output | |
| 1 | HI OUT | Output | HI judgment output : During HI judgment, output is ON |
| 2 | GO OUT | Output | GO judgment output : During GO judgment, output is ON |
| 3 | LO OUT | Output | LO judgment output : During LO judgment, output is ON |
| 14,15, 16 | HI COM GO COM LO COM | | Common of HI OUT, GO OUT, LO OUT judgment output (HI COM, LO COM, GO COM are connected internally) |
| 4 | HOLD | Input | Hold the display value and comparison output at Lo level input. |
| 5 | RESET | Input | Reset (OFF) the judgment at Lo level input. |
| 6 | 0ADJ. | Input | Hold resistance measurement value just before the change from Hi level to Lo level as zero adjustment and display the value obtained by subtracting the zero adjustment value from measurement value during Lo level. |
| 7 | TRG | Input | During HOLD, sample is done once if there is a change from Hi level to Lo level. After sampling (during display update), measurement data is output once in RS-232C and USB. Note: During the connection of RS-485, when the multiple units are controlled at the same time, there is a collision of data output, so control is done at different times. |
| 8 | EOC | Output | When sampling ends, it outputs 1ms of ON pulse. |
| 9 | ERR0 | Output | When resistance measurement is over, it outputs ON. (OHM, TC, TC RATIO, OHM RATIO) |
| 10 | ERR1 | Output | During TEMP calculation error with temperature correction, it outputs ON.(TC,TC RATIO) |
| 11 | ERR-CC | Output | When current output terminal is open (disconnected), it outputs ON. |
| 23 | MEM EN | Input | In Lo level input, specified memory is called with M-SEL0~M-SEL4. During this time, [EXT] is displayed on LCD display and external control status is displayed. |
| 18 19 20 21 22 | M-SEL0 M-SEL1 M-SEL2 M-SEL3 M-SEL4 | Input | Memory number of memory code table is specified. |
| 12,24 | COM | | Common input output signal other than judgment |
| 17 | Unused | | Unused pin It is connected to internal circuit, so don't use for relay etc. |
| 13,25 | A+, A- | Output | It is an optional analog output terminal. A+ : + pole of analog output A- : - pole of analog output NC in the case of no analog output. |

4.1.2 Memory selection

- ① When MEM EN signal is at Lo level, it is possible to select the memory.
[EXT] is displayed on LCD display.
- ② Code of memory number is entered.

Memory code table

| Signal | Weight | 0 | 1 | 2 | 3 | 4 | 5 | 6 | 7 | 8 | 9 | 10 | 11 | 12 | 13 | 14 | 15 |
|--------|--------|---|---|---|---|---|---|---|---|---|---|----|----|----|----|----|----|
| M-SEL0 | 1 | | ○ | | ○ | | ○ | | ○ | | ○ | | ○ | | ○ | | ○ |
| M-SEL1 | 2 | | | ○ | ○ | | | ○ | ○ | | | ○ | ○ | | | ○ | ○ |
| M-SEL2 | 4 | | | | | ○ | ○ | ○ | ○ | | | | | ○ | ○ | ○ | ○ |
| M-SEL3 | 8 | | | | | | | | | ○ | ○ | ○ | ○ | ○ | ○ | ○ | ○ |
| M-SEL4 | 16 | | | | | | | | | | | | | | | | |

| Signal | Weight | 16 | 17 | 18 | 19 | 20 | 21 | 22 | 23 | 24 | 25 | 26 | 27 | 28 | 29 | 30 | 31 |
|--------|--------|----|----|----|----|----|----|----|----|----|----|----|----|----|----|----|----|
| M-SEL0 | 1 | | ○ | | ○ | | ○ | | ○ | | ○ | | ○ | | ○ | | ○ |
| M-SEL1 | 2 | | | ○ | ○ | | | ○ | ○ | | | ○ | ○ | | | ○ | ○ |
| M-SEL2 | 4 | | | | | ○ | ○ | ○ | ○ | | | | | ○ | ○ | ○ | ○ |
| M-SEL3 | 8 | | | | | | | | | ○ | ○ | ○ | ○ | ○ | ○ | ○ | ○ |
| M-SEL4 | 16 | ○ | ○ | ○ | ○ | ○ | ○ | ○ | ○ | ○ | ○ | ○ | ○ | ○ | ○ | ○ | ○ |

- : Turned ON.
- Blank : Turned OFF.
- 0,31 : This code is invalid.
EXT. display is turned off.

Note: During HOLD, display does not change even when the memory is switched.
It will be reflected at the time of sampling start.

4.1.3 External control timing chart

① When sampling is done with TRG signal during HOLD

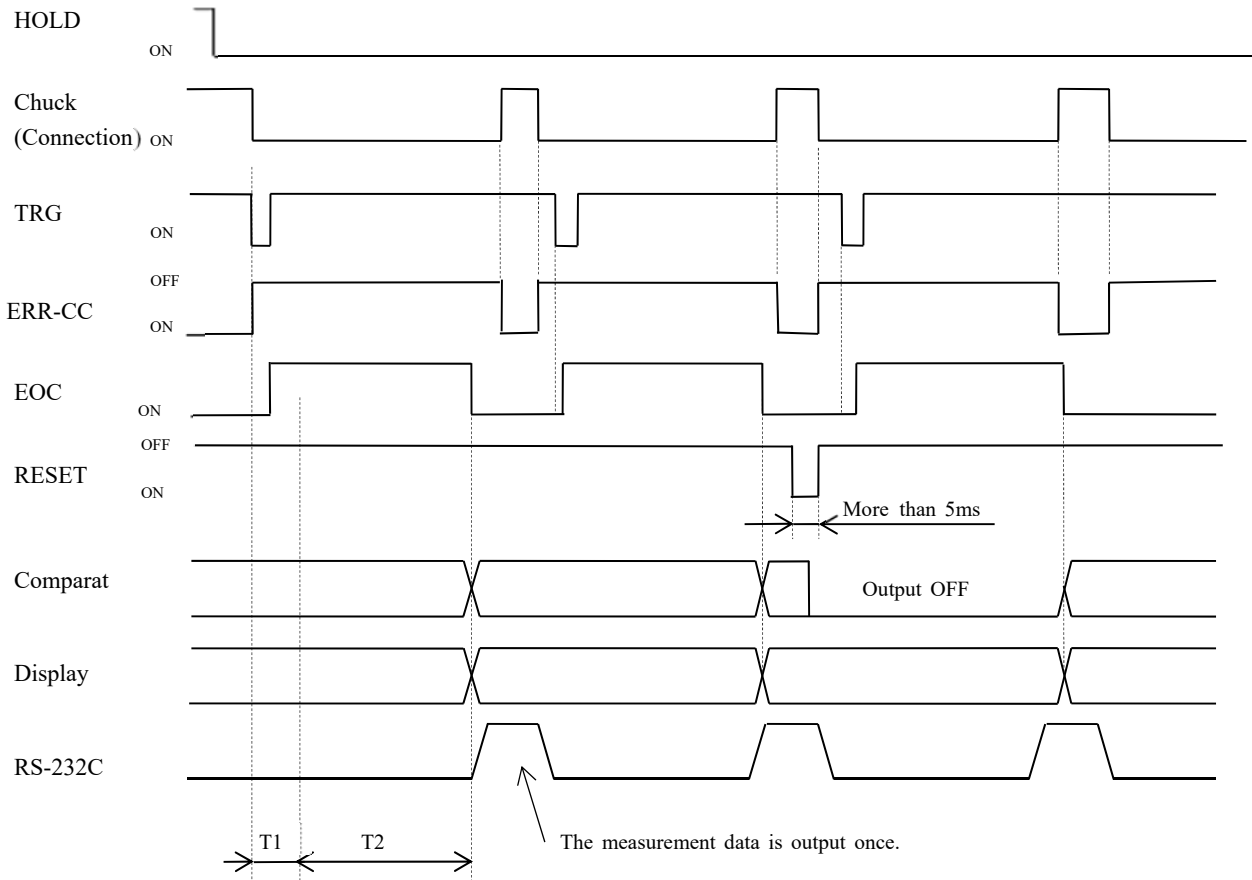

T : Response time

$$T = T1 + T2$$

T1 : Start delay

When range is changed during HOLD, 15ms of range switching time is added.

When the measurement current limit function is ON, 50ms is added.

T2 : Measurement time

$$\text{Sampling rate} \times \text{Average count} + \text{Processing time}$$

Processing time

Offset voltage correction function OFF

$$\text{Average count} \times 0.1\text{ms} + 3\text{ms}$$

Offset voltage correction function ON

$$\text{Average count} \times 0.1\text{ms} + 6\text{ms}$$

Operation description

1. After connecting the measurement probe, wait till the measurement value is stable (T1) and output of TRG signal is obtained in the resistance meter.
2. When TRG signal is ON, the sampling is started.
When sampling ends (T2), EOC is output together with the judgment output, update of the display and output of data in RS-232C and USB.
3. The judgment ends the next sampling and holds till the judgment output is renewed.
4. During HOLD, if RESET input is turned ON, judgment output is turned OFF.

When offset voltage correction function is ON and measurement current limit function is OFF

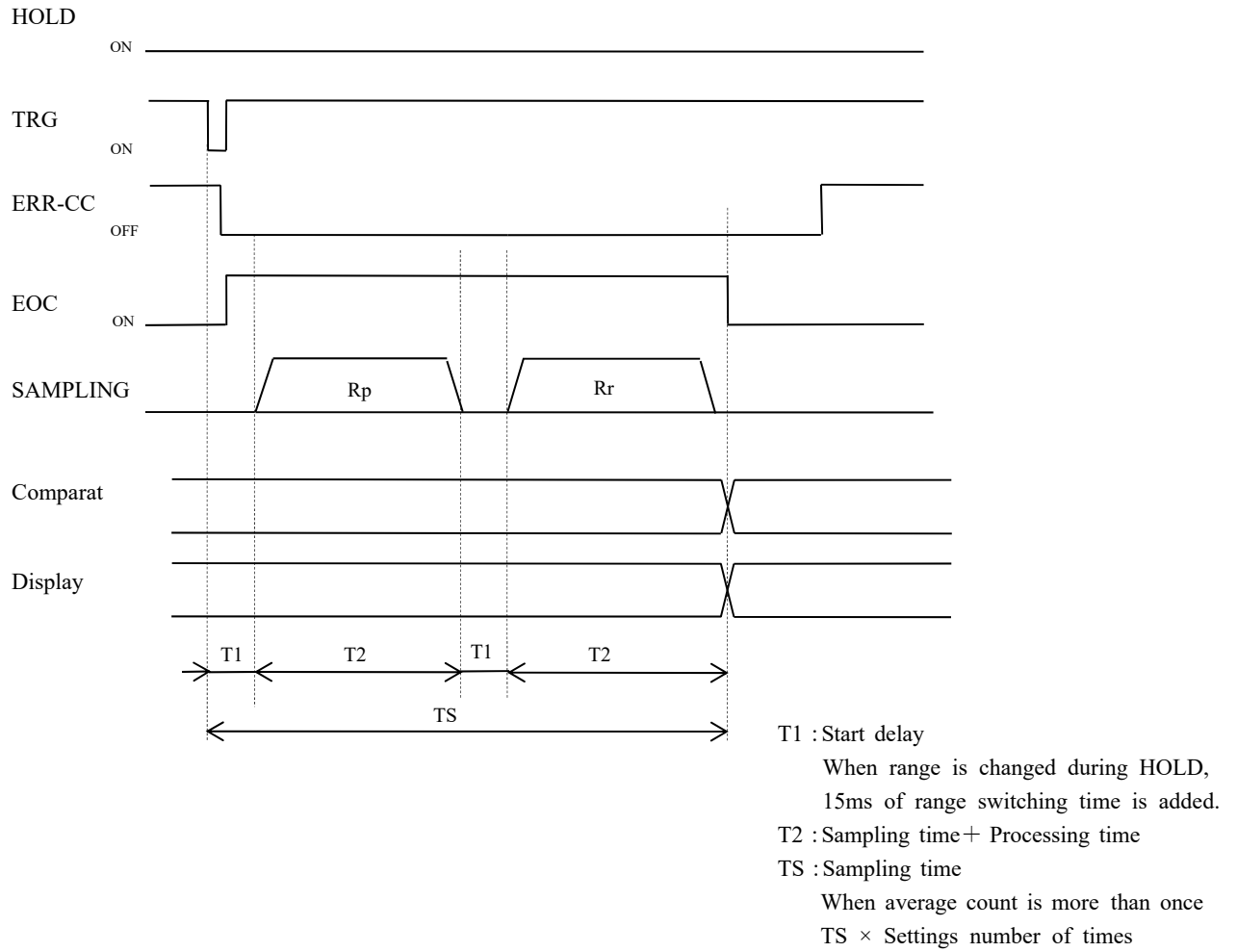

Operation description

1. When offset voltage correction function is set ON, the current output operates as one time sampling with the measurement of the positive electrode (R_p) and negative electrode (R_r).
The update period of judgment output and display is about 2 times.
During the current polarity reversal, start delay setting time (T_1) is waited for the circuit stability.

- ②When average calculation is performed (When average setting is greater than 1)
 Start sampling with TRG signal during HOLD.

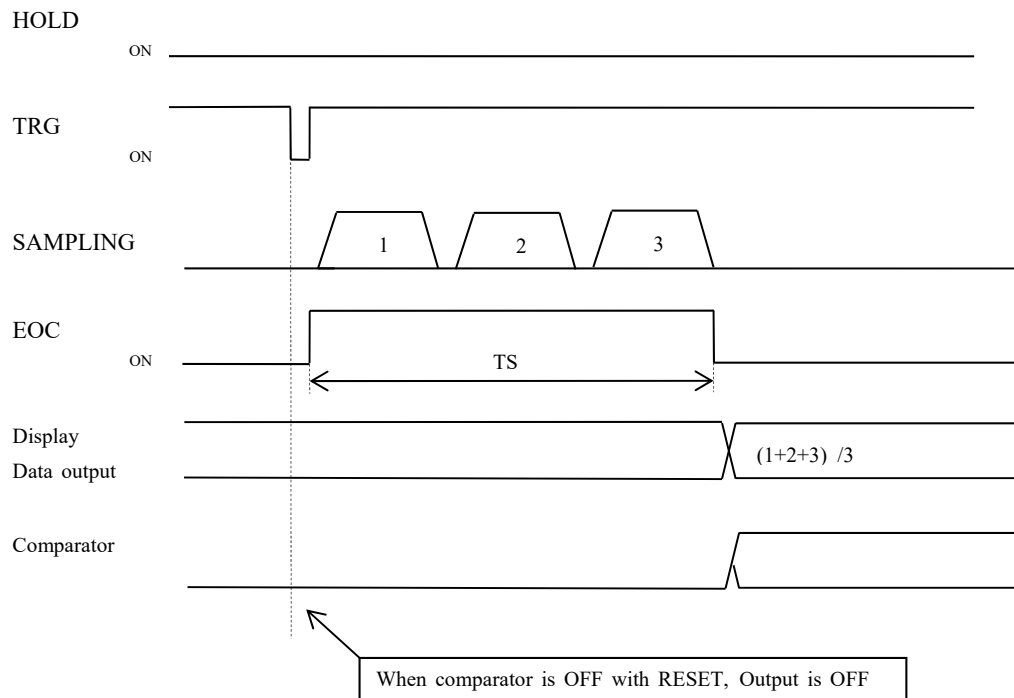

Operation description

1. When sampling is started with TRG signal during HOLD, after average count of sampling, judgment output and display are renewed.
 When offset voltage correction function is ON, as current positive electrode and current negative electrode becomes 1 sampling, the sampling time (Ts) becomes double.

Start sampling with HOLD release (OFF)

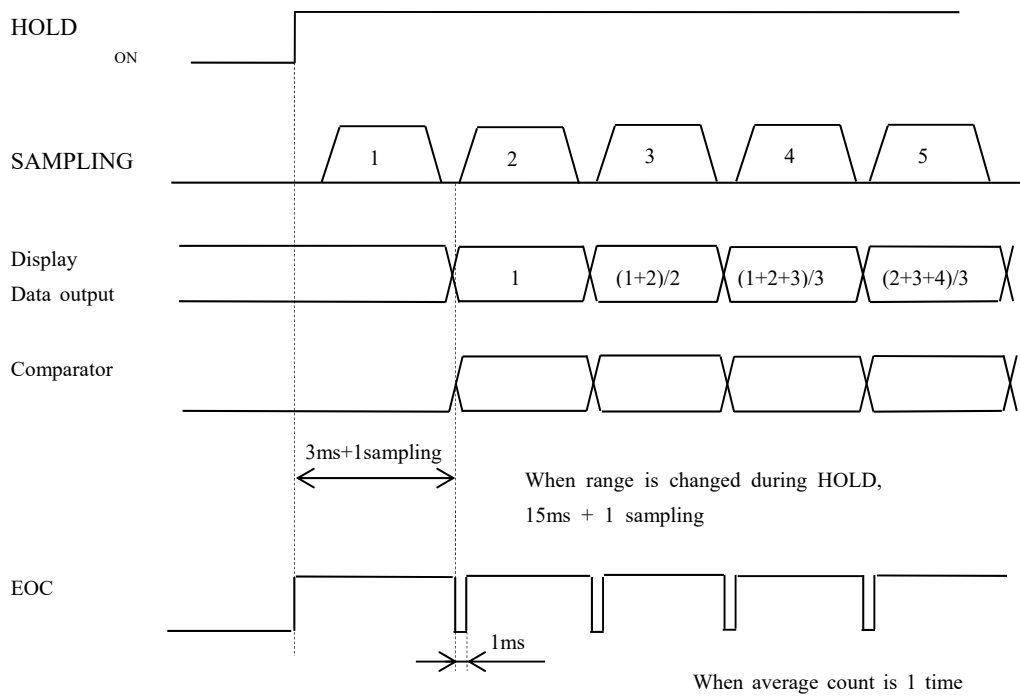

Operation description

1. When sampling is started with release (OFF) of HOLD during HOLD, judgment output and display are renewed in the first time sampling. The display value is average value till average count and beyond the average count, moving average value is displayed.

When HOLD is released (OFF) with the pulse within 1 sampling time

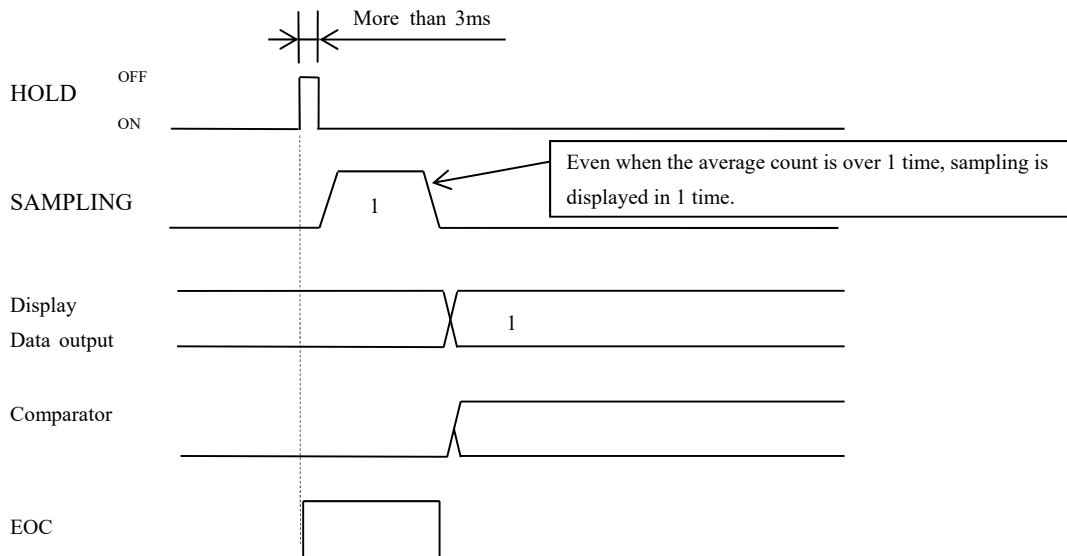

③When HOLD signal is opened (Free sampling)

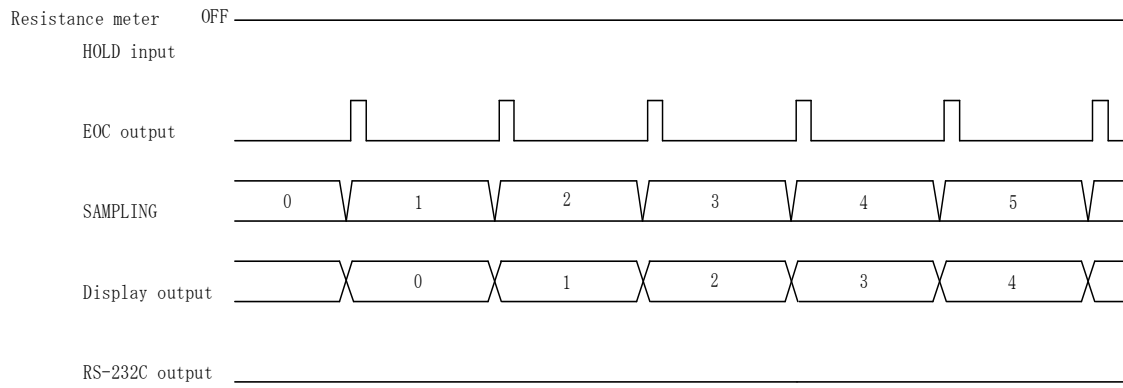

Operation description

1. 356G performs sampling repeatedly.

Judgment output and display are renewed before the end of sampling and simultaneously with EOC output.

When offset voltage correction function is ON, as current positive electrode and current negative electrode becomes 1 sampling, the sampling time (T_s) becomes double.

5. Communication (RS-232C, RS-485, USB)

The setting of this meter and the measurement data can be read with the communication interface.

Note: The connection of communication cable must be done in the state when the power cable of 356G is disconnected.

5.1●Specifications

5.1.1 Specifications of RS-232C, RS-485

| | |
|---------------------|---|
| Transmission system | RS-232C : Start-stop synchronous full duplex RS-485 : Start-stop synchronous half duplex |
| Transmission speed | 38400, 19200, 9600, 4800 bps (Set to 19200bps at delivery from factory) |
| Data bit length | 8 bit |
| Stop bit | 1 bit |
| Parity bit | Nil, even number, odd number (Set to nil at delivery from factory) |
| Delimiter | CR+LF |

5.1.2 Specifications of USB

| | |
|-----------|-----------|
| Class | HID class |
| Connector | Type B |

Note: The use of RS485 USB and RS-232C cannot be done simultaneously.

5.2●Connection

5.2.1 Connection of RS-232C

Meter connector D-sub 9 pin

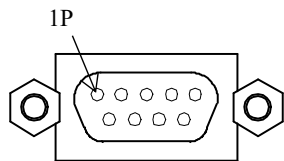

Connector in use[OMRON:XM2C-0942-132L]

| Pin No. | Signal name (JIS) | Direction | Name |
|---------|-------------------|-----------|-------------------|
| ① | | | Not in use |
| ② | RD (RXD) | Input | Receiving data |
| ③ | SD (TXD) | Output | Transmission data |
| ④ | | | Not in use |
| ⑤ | SG (GND) | | Ground for signal |
| ⑥ | | | Not in use |
| ⑦ | | | Not in use |
| ⑧ | | | Not in use |
| ⑨ | | | Not in use |

Connection cable : Use the cross cable 5881-11-018.

(The communication may not be possible when cable other than specified is used.)

Connection of cable

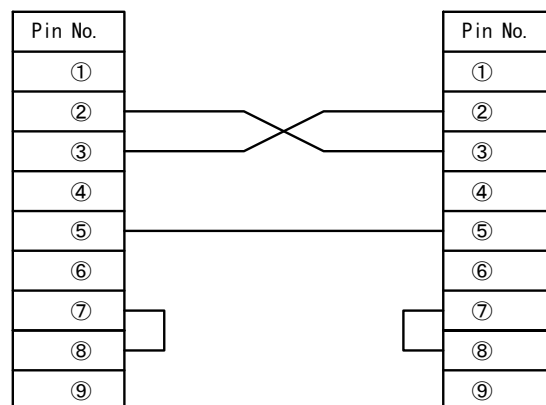

5.2.2 Connection of RS-485

RS-485 terminal, Terminator

| | | |
|--------------|----------|----------|
| Terminal No. | 1 | 2 |
| Signal Name | + (A) | - (B) |

If the rear panel switch is switched ON, the terminal resistor 200Ω will be connected in parallel.

If you want to use this meter in end station, terminator is switched ON.

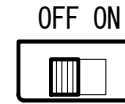

If high level computer is included, RS-485 can be connected up to 32 units.

Besides, for the both ends of the equipment of the transmission line, it is necessary to specify the end stations.

When specifying the end station, switch ON the terminator switch.

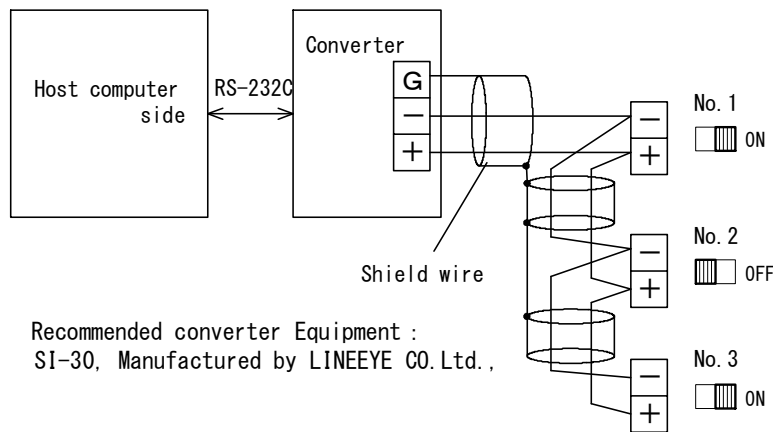

5.2.3 Connection of USB

Connect the cable with the included utility software.

5.3●Communication setting

The setting of equipment no., transmission speed and parity bit is done according to the type of the equipment. For setting method refer 3.16.1 Communication setting method.

| Setting items | Setting required interface | | |
|--------------------|----------------------------|---------|--------|
| | USB | RS-232C | RS-485 |
| Equipment no. | — ※ | — ※ | ○ ※ |
| Transmission speed | — | ○ | ○ |
| Parity bit | — | ○ | ○ |

— : No setting needed

○ : Setting needed

※ : The setting detail will be the equipment number of data.

When connecting multiple units with multi-drop connection of RS-485, do the setting so that the equipment number does not overlap.

5.4●Operation description

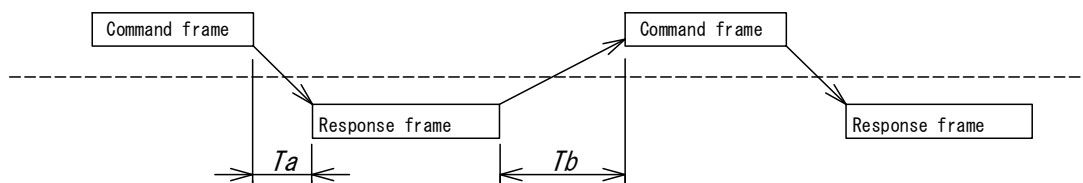

T_a Command response time : MAX About 50ms (WRITE MEMORY Command time MAX2.2sec)

T_b Command prohibition time after response : RS-232C, USB MAX 5ms
RS-485 MAX 15ms

Response frame: If a valid setting command is received, received content is returned.
If a valid output command is received, specified data is output.

Note: When performing data communication, use the ONLINE of 356G in the ON state.

When ONLINE performs communication during OFF, there is no response except read out command.

5.5●List of communication commands

| Read out command | Contents | Set and control command | Contents |
|------------------|---|-------------------------|--|
| MEM? | Read out the memory no. | MEM=CALL | Switching of memory no. |
| MEM01? | Read out the memory setting data of specified no. | WRITE MEMORY | Write down the setting value in the FLASH memory |
| COMP? | Read out comparator setting | COMP= | Comparator setting |
| FUNC? | Read out function | FUNCTION= | Function setting |
| RANGE? | Read out range setting | RANGE= | Range setting |
| HOLD? | Read out HOLD state | HOLD= | HOLD setting ON/OFF |
| RST? | Read out reset | RST= | Reset setting ON/OFF |
| SAMPLING? | Read out sampling setting | SAMPRING= | Sampling setting |
| RATIOSTD? | Read out RATIO setting | RATIOSTD= | RATIO setting |
| ZEROADJ? | Read out zero adjustment state | ZEROADJ= | Zero adjustment setting ON/OFF |
| ONLINE? | Read out online state | ONLINE= | Online setting ON: It is possible for each type of setting and read out (Including measurement value). OFF: Read out of measurement and setting is possible. |
| AVERAGE? | Read out average no. of times setting | AVERAGE= | Average no. of times setting |
| READ | Do sampling once and output data during HOLD | - | - |
| DATA? | Output measurement data | - | - |

5.6●Data format

5.6.1 Command frame

Request for read out of measurement data and setting

| | | | | | | | | |
|---|---|---|---|---|---|---|---|---|
| 0 | 1 | D | A | T | A | ? | C | L |
| | | | | | | | R | F |
| ① | | ② | | | | | ③ | |

Transmission of setting data

| | | | | | | | | | | | | | | | | |
|---|---|---|---|---|---|---|---|---|---|---|---|---|---|---|---|---|
| 0 | 1 | R | A | N | G | E | = | 3 | 0 | 0 | m | O | H | M | C | L |
| | | | | | | | | | | | | | | | R | F |
| ① | | ② | | | | | | | | | | | | ③ | | |

- ⊙ : Equipment no. (2characters)
- ⊙ : Command data (No. of characters depend on the command)
- ⊙ : Delimiter
 - CR: Carriage Return (13H)
 - LF: Line Feed (10H)

5.6.2 Response frame

| | | | | | | | | | | | | | | | | | |
|---|---|---|---|---|---|---|---|---|---|---|---|---|---|---|---|---|---|
| 0 | 1 | A | R | A | N | G | E | = | 3 | 0 | 0 | m | O | H | M | C | L |
| | | | | | | | | | | | | | | | | R | F |
| ① | | ② | ③ | | | | | | | | | | | | ④ | | |

- ⊙ : Equipment no. (2characters)
- ⊙ : Exit code (1character)

| Exit code | Contents | Description | Presence or absence of response to command | |
|-----------|------------------------|--|--|---|
| | | | = | ? |
| A (41H) | Normal | Command has been received | ○ | ○ |
| B (42H) | Under setting | Under panel setting with key operation | ○ | — |
| C (43H) | Setting error | Specify the outside range with setting command | ○ | — |
| D (44H) | CC | Source terminal is open during measurement data transmission | — | ○ |
| E (45H) | Under external control | Under external control REMOTE connector | ○ | — |
| F (46H) | Command error | Received the setting command when ONLINE is switched to OFF state and command data is not correct. | ○ | ○ |
| P (50H) | Protect error | Under protection circuit operation after overvoltage is applied to measurement terminal | — | ○ |

- ⊙ : Response data (No. of characters depend on the command)
- ⊙ : Delimiter
 - CR: Carriage Return (13H)
 - LF: Line Feed (10H)

5.7●Program data

5.7.1 DATA? ··· Read out of measurement data

Request for the read out of the measurement data

| | | | | | | | | | |
|---|---|---|---|---|---|---|---|---|---|
| 0 | 0 | 0 | 0 | 0 | 0 | 0 | 0 | 0 | 0 |
| 1 | 2 | 3 | 4 | 5 | 6 | 7 | 8 | 9 | |
| 0 | 1 | D | A | T | A | ? | C | L | |
| | | | | | | | R | F | |
| ① | ② | | | | | ③ | | | |

- ①: Equipment no.
- ②: Measurement data request command (DATA?)
- ③: Delimiter (CR+LF)

Response

●Resistance measurement (OHM)

| | | | | | | | | | | | | | | | | | | | | | |
|---|---|---|---|---|---|---|---|---|---|---|---|---|---|---|---|---|---|---|---|---|---|
| 0 | 0 | 0 | 0 | 0 | 0 | 0 | 0 | 0 | 1 | 1 | 1 | 1 | 1 | 1 | 1 | 1 | 1 | 2 | 2 | 2 | |
| 1 | 2 | 3 | 4 | 5 | 6 | 7 | 8 | 9 | 0 | 1 | 2 | 3 | 4 | 5 | 6 | 7 | 8 | 9 | 0 | 1 | 2 |
| 0 | 1 | A | O | H | M | ␣ | ␣ | = | ␣ | 1 | 2 | 3 | . | 4 | 5 | 6 | m | O | H | M | , |
| ① | ② | ③ | | | | | | | | | | | | | | ④ | | | ⑤ | | |

| | | | | | | | | | | | | | | | | | | | | | |
|---|---|---|---|---|---|---|---|---|---|---|---|---|---|---|---|---|---|---|---|---|--|
| 2 | 2 | 2 | 2 | 2 | 2 | 2 | 3 | 3 | 3 | 3 | 3 | 3 | 3 | 3 | 3 | 3 | 3 | 3 | 3 | 3 | |
| 3 | 4 | 5 | 6 | 7 | 8 | 9 | 0 | 1 | 2 | 3 | 4 | 5 | 6 | 7 | 8 | 9 | | | | | |
| ␣ | J | U | D | G | E | = | H | I | G | H | ␣ | L | O | W | C | L | | | | | |
| | | | | | | | | | | | | | | | R | F | | | | | |
| ⑥ | | | | | | | | | | | | | | | | ⑦ | | | | | |

- ①: Equipment no.
- ②: Exit code
- ③: Measurement data

| | | | | | | | | | | | | | | | |
|---|---|---|---|---|---|---|---|---|---|---|---|----------------------|--|--|--|
| O | H | M | = | ␣ | 3 | 0 | 0 | . | 0 | 0 | 0 | 300mΩ、300Ω | | | |
| O | H | M | = | ␣ | 3 | 0 | . | 0 | 0 | 0 | 0 | 30mΩ、30Ω | | | |
| O | H | M | = | ␣ | 3 | . | 0 | 0 | 0 | 0 | 0 | 3Ω | | | |
| O | H | M | = | - | 1 | 2 | 3 | . | 4 | 5 | 6 | During minus display | | | |

④: Unit

| | | | | | | | |
|---|---|---|---|-------------|--|--|--|
| m | O | H | M | 30mΩ、300mΩ | | | |
| ␣ | O | H | M | 3Ω、30Ω、300Ω | | | |

⑤: Punctuation

⑥: Judgment

| | | | | | | | | | | | | | | | | | | | |
|---|---|---|---|---|---|---|---|---|---|---|---|---|---|---|---------------------------|--|--|--|--|
| ␣ | J | U | D | G | E | = | H | I | G | H | ␣ | ␣ | ␣ | ␣ | During HIGH judgment | | | | |
| ␣ | J | U | D | G | E | = | L | O | W | ␣ | ␣ | ␣ | ␣ | ␣ | During LOW judgment | | | | |
| ␣ | J | U | D | G | E | = | G | O | O | D | ␣ | ␣ | ␣ | ␣ | During GOOD judgment | | | | |
| ␣ | J | U | D | G | E | = | H | I | G | H | ␣ | L | O | W | During HIGH LOW judgment | | | | |
| ␣ | J | U | D | G | E | = | O | F | F | ␣ | ␣ | ␣ | ␣ | ␣ | During no judgment(RESET) | | | | |

⑦: Delimiter (CR+LF)

Note) ␣ : Space (20H)

•Temperature measurement (TEMP)

| | | | | | | | | | | | | | | | | | | | | | | |
|---|---|---|---|---|---|---|---|---|---|---|---|---|---|---|---|---|---|---|---|---|---|---|
| 0 | 0 | 0 | 0 | 0 | 0 | 0 | 0 | 0 | 1 | 1 | 1 | 1 | 1 | 1 | 1 | 1 | 1 | 1 | 2 | 2 | 2 | 2 |
| 1 | 2 | 3 | 4 | 5 | 6 | 7 | 8 | 9 | 0 | 1 | 2 | 3 | 4 | 5 | 6 | 7 | 8 | 9 | 0 | 1 | 2 | 3 |
| 0 | 1 | A | T | E | M | P | Ⓢ | = | Ⓢ | Ⓢ | Ⓢ | 1 | 0 | 0 | . | 0 | Ⓢ | ' | C | Ⓢ | C | L |
| | | | | | | | | | | | | | | | | | | | | | R | F |
| ① | ② | ③ | | | | | | | | | | | | | | ④ | | | ⑤ | | | |

⓪ : Equipment no.

⓫ : Exit code

⓬ : Measurement data

| | | | | | | | | | | | | | | | | | | | | | |
|---|---|---|---|---|---|---|---|---|---|---|---|---|----------------|--|--|--|--|--|--|--|--|
| T | E | M | P | = | Ⓢ | Ⓢ | Ⓢ | 1 | 0 | 0 | . | 0 | During 100.0°C | | | | | | | | |
| T | E | M | P | = | Ⓢ | Ⓢ | Ⓢ | Ⓢ | 2 | 4 | . | 5 | During 24.5°C | | | | | | | | |
| T | E | M | P | = | - | Ⓢ | Ⓢ | Ⓢ | 1 | 9 | . | 9 | During -19.9°C | | | | | | | | |

⓪ : Unit

⓫ : Delimiter (CR+LF)

•Temperature correction (TC)

| | | | | | | | | | | | | | | | | | | | | | | |
|---|---|---|---|---|---|---|---|---|---|---|---|---|---|---|---|---|---|---|---|---|---|---|
| 0 | 0 | 0 | 0 | 0 | 0 | 0 | 0 | 0 | 1 | 1 | 1 | 1 | 1 | 1 | 1 | 1 | 1 | 1 | 2 | 2 | 2 | 2 |
| 1 | 2 | 3 | 4 | 5 | 6 | 7 | 8 | 9 | 0 | 1 | 2 | 3 | 4 | 5 | 6 | 7 | 8 | 9 | 0 | 1 | 2 | 3 |
| 0 | 1 | A | T | . | C | Ⓢ | Ⓢ | = | Ⓢ | 2 | 9 | 9 | . | 9 | 9 | 9 | Ⓢ | O | H | M | , | |
| ① | ② | ③ | | | | | | | | | | | | | | ⑥ | | | ⑦ | | | |

| | | | | | | | | | | | | | | | | | | | | | | |
|---|---|---|---|---|---|---|---|---|---|---|---|---|---|---|---|---|---|---|---|---|---|---|
| 2 | 2 | 2 | 2 | 2 | 2 | 2 | 2 | 3 | 3 | 3 | 3 | 3 | 3 | 3 | 3 | 3 | 3 | 3 | 3 | 3 | 3 | 3 |
| 3 | 4 | 5 | 6 | 7 | 8 | 9 | 0 | 1 | 2 | 3 | 4 | 5 | 6 | 7 | 8 | | | | | | | |
| R | Ⓢ | = | Ⓢ | 3 | 0 | 0 | . | 0 | 0 | 0 | m | O | H | M | , | | | | | | | |
| ④ | | | | | | | | | | | | | | ⑥ | | | ⑦ | | | | | |

| | | | | | | | | | | | | | | | | | | | | | | |
|---|---|---|---|---|---|---|---|---|---|---|---|---|---|---|---|---|---|---|---|---|---|---|
| 3 | 4 | 4 | 4 | 4 | 4 | 4 | 4 | 4 | 4 | 4 | 4 | 4 | 5 | 5 | 5 | 5 | 5 | 5 | 5 | 5 | 5 | 5 |
| 9 | 0 | 1 | 2 | 3 | 4 | 5 | 6 | 7 | 8 | 9 | 0 | 1 | 2 | 3 | 4 | 5 | 6 | | | | | |
| T | E | M | P | = | Ⓢ | Ⓢ | Ⓢ | Ⓢ | 3 | 9 | . | 9 | Ⓢ | ' | C | Ⓢ | , | | | | | |
| ⑤ | | | | | | | | | | | | | | ⑥ | | | ⑦ | | | | | |

| | | | | | | | | | | | | | | | | | | | | | | |
|---|---|---|---|---|---|---|---|---|---|---|---|---|---|---|---|---|---|--|--|--|--|--|
| 5 | 5 | 5 | 6 | 6 | 6 | 6 | 6 | 6 | 6 | 6 | 6 | 6 | 6 | 7 | 7 | 7 | 7 | | | | | |
| 7 | 8 | 9 | 0 | 1 | 2 | 3 | 4 | 5 | 6 | 7 | 8 | 9 | 0 | 1 | 2 | 3 | | | | | | |
| Ⓢ | J | U | D | G | E | = | H | I | G | H | Ⓢ | L | O | W | C | L | | | | | | |
| ⑧ | | | | | | | | | | | | | | ⑧ | | | | | | | | |

⓪ : Equipment no.

⓫ : Exit code

⓬ : Correction resistance value (R_T)

⓭ : Resistance measurement value (R_t)

⓮ : Ambient temperature (t)

⓪ : Unit

⓫ : Punctuation

⓬ : Delimiter (CR+LF)

•Ratio (OHM RATIO,TC RATIO)

| | | | | | | | | | | | | | | | | | | | | | |
|---|---|---|---|---|---|---|---|---|---|---|---|---|---|---|---|---|---|---|---|---|---|
| 0 | 0 | 0 | 0 | 0 | 0 | 0 | 0 | 0 | 1 | 1 | 1 | 1 | 1 | 1 | 1 | 1 | 1 | 1 | 2 | 2 | 2 |
| 1 | 2 | 3 | 4 | 5 | 6 | 7 | 8 | 9 | 0 | 1 | 2 | 3 | 4 | 5 | 6 | 7 | 8 | 9 | 0 | 1 | 2 |
| 0 | 1 | A | R | A | T | I | O | = | Ⓢ | Ⓢ | Ⓢ | 1 | 9 | 9 | . | 9 | Ⓢ | Ⓢ | % | Ⓢ | , |
| ① | | ② | | ③ | | | | | | | | | | | ⑥ | | | ⑦ | | | |

| | | | | | | | | | | | | | | | | | | | | | |
|---|---|---|---|---|---|---|---|---|---|---|---|---|---|---|---|---|---|---|---|---|---|
| 2 | 2 | 2 | 2 | 2 | 2 | 2 | 2 | 3 | 3 | 3 | 3 | 3 | 3 | 3 | 3 | 3 | 3 | 3 | 3 | 3 | 3 |
| 3 | 4 | 5 | 6 | 7 | 8 | 9 | 0 | 1 | 2 | 3 | 4 | 5 | 6 | 7 | 8 | | | | | | |
| R | s | = | Ⓢ | 3 | 0 | 0 | . | 0 | 0 | 0 | m | O | H | M | , | | | | | | |
| ④ | | | | | | | | | | | ⑥ | | | | | ⑦ | | | | | |

| | | | | | | | | | | | | | | | | | | | | | |
|---|---|---|---|---|---|---|---|---|---|---|---|---|---|---|---|---|---|---|---|---|---|
| 3 | 4 | 4 | 4 | 4 | 4 | 4 | 4 | 4 | 4 | 4 | 4 | 5 | 5 | 5 | 5 | 5 | 5 | 5 | 5 | 5 | 5 |
| 9 | 0 | 1 | 2 | 3 | 4 | 5 | 6 | 7 | 8 | 9 | 0 | 1 | 2 | 3 | 4 | | | | | | |
| R | x | = | Ⓢ | 1 | 9 | 9 | . | 9 | 9 | 9 | m | O | H | M | , | | | | | | |
| ⑤ | | | | | | | | | | | ⑥ | | | | | ⑦ | | | | | |

| | | | | | | | | | | | | | | | | | | | | | |
|---|---|---|---|---|---|---|---|---|---|---|---|---|---|---|---|---|---|--|--|--|--|
| 5 | 5 | 5 | 5 | 5 | 6 | 6 | 6 | 6 | 6 | 6 | 6 | 6 | 6 | 6 | 6 | 7 | 7 | | | | |
| 5 | 6 | 7 | 8 | 9 | 0 | 1 | 2 | 3 | 4 | 5 | 6 | 7 | 8 | 9 | 0 | 1 | | | | | |
| Ⓢ | J | U | D | G | E | = | H | I | G | H | Ⓢ | L | O | W | C | L | | | | | |
| ⑧ | | | | | | | | | | | | | | | ⑧ | | | | | | |

- Ⓢ : Equipment no.
- Ⓢ : Exit code
- Ⓢ : Ratio calculation value
- Ⓢ : Standard resistance value (Rs)
- Ⓢ : During OHM RATIO : Resistance measurement value
During T.C RATIO : Temperature correction value
- Ⓢ : Unit
- Ⓢ : Punctuation
- Ⓢ : Delimiter (CR+LF)

5.7.4 RANGE? ... Read out of measurement range

Request of read out

| | | | | | | | | | | | |
|---|---|---|---|---|---|---|---|---|---|---|--|
| 0 | 0 | 0 | 0 | 0 | 0 | 0 | 0 | 0 | 0 | 1 | |
| 1 | 2 | 3 | 4 | 5 | 6 | 7 | 8 | 9 | 0 | | |
| 0 | 1 | R | A | N | G | E | ? | C | L | | |
| | | | | | | | | R | F | | |
| ① | | ② | | | | | | ③ | | | |

- ⓪: Equipment no.
- Ⓛ: Range request command (RANGE?)
- Ⓞ: Delimiter (CR+LF)

Response

| | | | | | | | | | | | | | | | | | |
|---|---|---|---|---|---|---|---|---|---|---|---|---|---|---|---|---|---|
| 0 | 0 | 0 | 0 | 0 | 0 | 0 | 0 | 0 | 1 | 1 | 1 | 1 | 1 | 1 | 1 | 1 | 1 |
| 1 | 2 | 3 | 4 | 5 | 6 | 7 | 8 | 9 | 0 | 1 | 2 | 3 | 4 | 5 | 6 | 7 | 8 |
| 0 | 1 | A | R | A | N | G | E | = | 3 | 0 | 0 | m | O | H | M | C | L |
| | | | | | | | | | | | | | | | | R | F |
| ① | | ② | | ③ | | | | | | | | | | | ④ | | |

- ⓪: Equipment no.
- Ⓛ: Exit code
- Ⓞ: Range setting

| | | | | | | | | | | | | | |
|---|---|---|---|---|---|---|---|---|---|---|---|---|-------|
| R | A | N | G | E | = | Ⓜ | 3 | 0 | m | O | H | M | 30mΩ |
| R | A | N | G | E | = | 3 | 0 | 0 | m | O | H | M | 300mΩ |
| R | A | N | G | E | = | Ⓜ | Ⓜ | 3 | Ⓜ | O | H | M | 3Ω |
| R | A | N | G | E | = | Ⓜ | 3 | 0 | Ⓜ | O | H | M | 30Ω |
| R | A | N | G | E | = | 3 | 0 | 0 | Ⓜ | O | H | M | 300Ω |
| R | A | N | G | E | = | A | U | T | O | Ⓜ | Ⓜ | Ⓜ | AUTO |

- Ⓞ: Delimiter (CR+LF)
- Note)** Ⓜ: Space (20H)

5.7.5 RANGE= ... Setting of range

Range setting

| | | | | | | | | | | | | | | | | |
|---|---|---|---|---|---|---|---|---|---|---|---|---|---|---|---|---|
| 0 | 0 | 0 | 0 | 0 | 0 | 0 | 1 | 1 | 1 | 1 | 1 | 1 | 1 | 1 | 2 | 2 |
| 1 | 2 | 3 | 4 | 5 | 6 | 7 | 0 | 1 | 2 | 3 | 4 | 5 | 6 | 7 | 0 | 1 |
| 0 | 1 | R | A | N | G | E | = | 3 | 0 | 0 | m | O | H | M | C | L |
| | | | | | | | | | | | | | | | R | F |
| ① | | ② | | | | | | | | | | | ③ | | | |

- ⓪: Equipment no.
- Ⓛ: Range setting

| | | | | | | | | | | | | | |
|---|---|---|---|---|---|---|---|---|---|---|---|---|-------|
| R | A | N | G | E | = | Ⓜ | 3 | 0 | m | O | H | M | 30mΩ |
| R | A | N | G | E | = | 3 | 0 | 0 | m | O | H | M | 300mΩ |
| R | A | N | G | E | = | Ⓜ | Ⓜ | 3 | Ⓜ | O | H | M | 3Ω |
| R | A | N | G | E | = | Ⓜ | 3 | 0 | Ⓜ | O | H | M | 30Ω |
| R | A | N | G | E | = | 3 | 0 | 0 | Ⓜ | O | H | M | 300Ω |
| R | A | N | G | E | = | A | U | T | O | Ⓜ | Ⓜ | Ⓜ | AUTO |

- Ⓞ: Delimiter (CR+LF)
- Note)** Ⓜ: Space (20H)

Response

| | | | | |
|---|---|---|---|---|
| 0 | 0 | 0 | 0 | 0 |
| 1 | 2 | 3 | 4 | 5 |
| 0 | 1 | A | C | L |
| | | R | F | |
| ① | | ② | | ③ |

- ⓪: Equipment no.
- Ⓛ: Exit code
- Ⓞ: Delimiter (CR+LF)

5.7.6 SAMPLING? ... Read out of sampling

Request of read out

| | | | | | | | | | | | | | |
|---|---|---|---|---|---|---|---|---|---|---|---|---|---|
| 0 | 0 | 0 | 0 | 0 | 0 | 0 | 0 | 0 | 0 | 1 | 1 | 1 | 1 |
| 1 | 2 | 3 | 4 | 5 | 6 | 7 | 8 | 9 | 0 | 1 | 2 | 3 | |
| 0 | 1 | S | A | M | P | L | I | N | G | ? | C | L | |
| | | | | | | | | | | | R | F | |
| ① | | ② | | | | | | | | | ③ | | |

- ⓪: Equipment no.
- Ⓛ: Sampling request command (SAMPLING?)
- Ⓞ: Delimiter (CR+LF)

Response

| | | | | | | | | | | | | | | | | | | | |
|---|---|---|---|---|---|---|---|---|---|---|---|---|---|---|---|---|---|---|---|
| 0 | 0 | 0 | 0 | 0 | 0 | 0 | 0 | 0 | 0 | 1 | 1 | 1 | 1 | 1 | 1 | 1 | 1 | 1 | 2 |
| 1 | 2 | 3 | 4 | 5 | 6 | 7 | 8 | 9 | 0 | 1 | 2 | 3 | 4 | 5 | 6 | 7 | 8 | 9 | 0 |
| 0 | 1 | A | S | A | M | P | L | I | N | G | = | M | E | D | I | U | M | C | L |
| | | | | | | | | | | | | | | | | | | R | F |
| ① | | ② | | ③ | | | | | | | | | | | | | ④ | | |

- ⓪: Equipment no.
- Ⓛ: Exit code
- Ⓞ: Sampling setting

| | | | | | | | | | | | | | | | |
|---|---|---|---|---|---|---|---|---|---|---|---|---|---|---|--------|
| S | A | M | P | L | I | N | G | = | S | L | O | W | Ⓜ | Ⓜ | SLOW |
| S | A | M | P | L | I | N | G | = | M | E | D | I | U | M | MEDIUM |
| S | A | M | P | L | I | N | G | = | F | A | S | T | Ⓜ | Ⓜ | FAST |

- Ⓞ: Delimiter (CR+LF)
- Note)** Ⓜ: Space (20H)

5.7.7 SAMPLING= ... Setting of sampling

Sampling setting

| | | | | | | | | | | | | | | | | | | | |
|---|---|---|---|---|---|---|---|---|---|---|---|---|---|---|---|---|---|---|---|
| 0 | 0 | 0 | 0 | 0 | 0 | 0 | 0 | 0 | 0 | 1 | 1 | 1 | 1 | 1 | 1 | 1 | 1 | 1 | 1 |
| 1 | 2 | 3 | 4 | 5 | 6 | 7 | 8 | 9 | 0 | 1 | 2 | 3 | 4 | 5 | 6 | 7 | 8 | 9 | |
| 0 | 1 | S | A | M | P | L | I | N | G | = | M | E | D | I | U | M | C | L | |
| | | | | | | | | | | | | | | | | | R | F | |
| ① | | ② | | | | | | | | | | | | | ③ | | | | |

- ⓪: Equipment no.
- Ⓛ: Sampling setting

| | | | | | | | | | | | | | | | |
|---|---|---|---|---|---|---|---|---|---|---|---|---|---|---|--------|
| S | A | M | P | L | I | N | G | = | S | L | O | W | Ⓜ | Ⓜ | SLOW |
| S | A | M | P | L | I | N | G | = | M | E | D | I | U | M | MEDIUM |
| S | A | M | P | L | I | N | G | = | F | A | S | T | Ⓜ | Ⓜ | FAST |

- Ⓞ: Delimiter (CR+LF)
- Note)** Ⓜ: Space (20H)

Response

| | | | | |
|---|---|---|---|---|
| 0 | 0 | 0 | 0 | 0 |
| 1 | 2 | 3 | 4 | 5 |
| 0 | 1 | A | C | L |
| | | R | F | |
| ① | | ② | | ③ |

- ⓪: Equipment no.
- Ⓛ: Exit code
- Ⓞ: Delimiter (CR+LF)

5.7.8 AVERAGE? ... Read out of average no. of times

Request of read out

| | | | | | | | | | | | | |
|---|---|---|---|---|---|---|---|---|---|---|---|---|
| 0 | 0 | 0 | 0 | 0 | 0 | 0 | 0 | 0 | 0 | 1 | 1 | 1 |
| 1 | 2 | 3 | 4 | 5 | 6 | 7 | 8 | 9 | 0 | 0 | 1 | 2 |
| 0 | 1 | A | V | E | R | A | G | E | ? | C | L | |
| | | | | | | | | | | R | F | |
| ① | | ② | | | | | | | | ③ | | |

①: Equipment no.

②: Average no. of times request command (AVETIME?)

③: Delimiter (CR+LF)

Response

| | | | | | | | | | | | | | | | | |
|---|---|---|---|---|---|---|---|---|---|---|---|---|---|---|---|---|
| 0 | 0 | 0 | 0 | 0 | 0 | 0 | 0 | 0 | 0 | 1 | 1 | 1 | 1 | 1 | 1 | 1 |
| 1 | 2 | 3 | 4 | 5 | 6 | 7 | 8 | 9 | 0 | 1 | 2 | 3 | 4 | 5 | 6 | |
| 0 | 1 | A | A | V | E | R | A | G | E | = | 1 | 0 | 0 | C | L | |
| | | | | | | | | | | | | | | R | F | |
| ① | | ② | | ③ | | | | | | | | | | ④ | | |

①: Equipment no.

②: Exit code

③: Average no. of times setting

| | | | | | | | | | | | |
|---|---|---|---|---|---|---|---|---|---|---|-----------|
| A | V | E | R | A | G | E | = | 1 | 0 | 0 | 100 times |
| A | V | E | R | A | G | E | = | 0 | 1 | 0 | 10 times |

④: Delimiter (CR+LF)

Note) □: Space (20H)

5.7.9 AVERAGE= ... Average no. of times setting

Average no. of times setting

| | | | | | | | | | | | | | | | |
|---|---|---|---|---|---|---|---|---|---|---|---|---|---|---|---|
| 0 | 0 | 0 | 0 | 0 | 0 | 0 | 0 | 0 | 0 | 1 | 1 | 1 | 1 | 1 | 1 |
| 1 | 2 | 3 | 4 | 5 | 6 | 7 | 8 | 9 | 0 | 1 | 2 | 3 | 4 | 5 | |
| 0 | 1 | A | V | E | R | A | G | E | = | □ | 9 | 0 | C | L | |
| | | | | | | | | | | | | | R | F | |
| ① | | ② | | | | | | | | | | ③ | | | |

①: Equipment no.

②: Average no. of times (1~100 time)

| | | | | | | | | | | | |
|---|---|---|---|---|---|---|---|---|---|---|-----------|
| A | V | E | R | A | G | E | = | 1 | 0 | 0 | 100 times |
| A | V | E | R | A | G | E | = | □ | □ | 1 | 1 time |

③: Delimiter (CR+LF)

Note) □: Space (20H)

Response

| | | | | |
|---|---|---|---|---|
| 0 | 0 | 0 | 0 | 0 |
| 1 | 2 | 3 | 4 | 5 |
| 0 | 1 | A | C | L |
| | | | R | F |
| ① | | ② | | ③ |

①: Equipment no.

②: Exit code

③: Delimiter (CR+LF)

5.7.10 COMP? ... Read out of comparator setting

When function is OHM and TC, setting of comparator HIGH, LOW is read out.

Request of read out

| | | | | | | | | | | |
|---|---|---|---|---|---|---|---|---|---|--|
| 0 | 0 | 0 | 0 | 0 | 0 | 0 | 0 | 0 | 0 | |
| 1 | 2 | 3 | 4 | 5 | 6 | 7 | 8 | 9 | | |
| 0 | 1 | C | O | M | P | ? | C | L | | |
| | | | | | | | R | F | | |
| ① | | ② | | | | | ③ | | | |

- ①: Equipment no.
- ②: Comparator setting request command (COMP?)
- ③: Delimiter (CR+LF)

Response

| | | | | | | | | | | | | | | | | | | | | | |
|---|---|---|---|---|---|---|---|---|---|---|---|---|---|---|---|---|---|---|---|---|---|
| 0 | 0 | 0 | 0 | 0 | 0 | 0 | 0 | 0 | 0 | 1 | 1 | 1 | 1 | 1 | 1 | 1 | 1 | 1 | 2 | 2 | 2 |
| 1 | 2 | 3 | 4 | 5 | 6 | 7 | 8 | 9 | 0 | 1 | 2 | 3 | 4 | 5 | 6 | 7 | 8 | 9 | 0 | 1 | 2 |
| 0 | 1 | A | C | O | M | P | = | H | ␣ | 3 | 0 | 0 | . | 0 | 0 | 0 | m | O | H | M | , |
| ① | | ② | ③ | | | | | ④ | | | | | | | | | | ⑥ | | | |

| | | | | | | | | | | | | | | | |
|---|---|---|---|---|---|---|---|---|---|---|---|---|---|---|---|
| 2 | 2 | 2 | 2 | 2 | 2 | 2 | 3 | 3 | 3 | 3 | 3 | 3 | 3 | 3 | 3 |
| 3 | 4 | 5 | 6 | 7 | 8 | 9 | 0 | 1 | 2 | 3 | 4 | 5 | 6 | 7 | |
| L | ␣ | 1 | 0 | 0 | . | 0 | 0 | 0 | m | O | H | M | C | L | |
| | | | | | | | | | | | | | R | F | |
| ⑤ | | | | | | | | | | | | | ⑦ | | |

- ①: Equipment no.
- ②: Exit code
- ③: Comparator setting
- ④: HIGH setting
- ⑤: LOW setting

| | | | | | | | | | | | | | | | |
|---|---|---|---|---|---|---|---|---|---|---|---|---|------|----------|---|
| H | ␣ | 1 | 9 | 9 | . | 9 | 9 | 9 | ␣ | O | H | M | HIGH | 199.999 | Ω |
| L | ␣ | ␣ | 1 | 0 | . | 0 | 0 | 0 | ␣ | O | H | M | LOW | 10.000 | Ω |
| H | ␣ | 1 | 9 | . | 9 | 9 | 9 | 9 | ␣ | O | H | M | HIGH | 19.9999 | Ω |
| L | - | ␣ | 1 | . | 0 | 0 | 0 | 0 | ␣ | O | H | M | LOW | - 1.0000 | Ω |

- ⑥: Punctuation
- ⑦: Delimiter (CR+LF)

Note) ␣: Space (20H)

5.7.11 COMP= ... Comparator setting

When function is OHM and TC, setting of comparator HIGH, LOW is done.

Comparator setting

| | | | | | | | | | | | | | | | | | | | | |
|---|---|---|---|---|---|---|---|---|---|---|---|---|---|---|---|---|---|---|---|---|
| 0 | 0 | 0 | 0 | 0 | 0 | 0 | 0 | 0 | 0 | 1 | 1 | 1 | 1 | 1 | 1 | 1 | 1 | 1 | 2 | 2 |
| 1 | 2 | 3 | 4 | 5 | 6 | 7 | 8 | 9 | 0 | 1 | 2 | 3 | 4 | 5 | 6 | 7 | 8 | 9 | 0 | 1 |
| 0 | 1 | C | O | M | P | = | H | ␣ | 3 | 0 | 0 | . | 0 | 0 | 0 | m | O | H | M | , |
| ① | | ② | | | | | ③ | | | | | | | | | | | | | ⑤ |

| | | | | | | | | | | | | | | | |
|---|---|---|---|---|---|---|---|---|---|---|---|---|---|---|---|
| 2 | 2 | 2 | 2 | 2 | 2 | 2 | 2 | 3 | 3 | 3 | 3 | 3 | 3 | 3 | 3 |
| 2 | 3 | 4 | 5 | 6 | 7 | 8 | 9 | 0 | 1 | 2 | 3 | 4 | 5 | 6 | |
| L | ␣ | 1 | 0 | 0 | . | 0 | 0 | 0 | m | O | H | M | C | L | |
| ④ | | | | | | | | | | | | | R | F | ⑥ |

- ⓪ : Equipment no.
- Ⓛ : Comparator setting
- Ⓜ : HIGH setting
- Ⓨ : LOW setting

| | | | | | | | | | | | | | | | |
|---|---|---|---|---|---|---|---|---|---|---|---|---|------|---------|---|
| H | ␣ | 1 | 9 | 9 | . | 9 | 9 | 9 | ␣ | O | H | M | HIGH | 199.999 | Ω |
| L | ␣ | ␣ | 1 | 0 | . | 0 | 0 | 0 | ␣ | O | H | M | LOW | 10.000 | Ω |
| H | ␣ | 1 | 9 | . | 9 | 9 | 9 | 9 | ␣ | O | H | M | HIGH | 19.9999 | Ω |
| L | - | ␣ | 1 | . | 0 | 0 | 0 | 0 | ␣ | O | H | M | LOW | -1.0000 | Ω |

Set the unit of HIGH setting and LOW setting to the same unit.

If different units are set, the unit of HIGH setting will be valid.

- ⓐ : Punctuation
- Ⓡ : Delimiter (CR+LF)

Note) ␣ : Space (20H)

5.7.12 RATIOSTD? ... Read out the ratio setting

When function is OHM RATIO and TC RATIO, the standard resistance and deviation are read out.

Request of read out

| | | | | | | | | | | | | | |
|---|---|---|---|---|---|---|---|---|---|---|---|---|---|
| 0 | 0 | 0 | 0 | 0 | 0 | 0 | 0 | 0 | 0 | 1 | 1 | 1 | 1 |
| 1 | 2 | 3 | 4 | 5 | 6 | 7 | 8 | 9 | 0 | 1 | 2 | 3 | |
| 0 | 1 | R | A | T | I | O | S | T | D | ? | C | L | |
| | | | | | | | | | | | R | F | |
| ① | | ② | | | | | | | | | | ③ | |

- ⓪ : Equipment no.
- Ⓛ : Ratio setting request command (RATIOSTD?)
- Ⓜ : Delimiter (CR+LF)

Response

| | | | | | | | | | | | | | | | | | | | | | | | | |
|---|---|---|---|---|---|---|---|---|---|---|---|---|---|---|---|---|---|---|---|---|---|---|---|---|
| 0 | 0 | 0 | 0 | 0 | 0 | 0 | 0 | 0 | 0 | 1 | 1 | 1 | 1 | 1 | 1 | 1 | 1 | 1 | 2 | 2 | 2 | 2 | 2 | 2 |
| 1 | 2 | 3 | 4 | 5 | 6 | 7 | 8 | 9 | 0 | 1 | 2 | 3 | 4 | 5 | 6 | 7 | 8 | 9 | 0 | 1 | 2 | 3 | 4 | 5 |
| 0 | 1 | A | R | A | T | I | O | S | T | D | = | Ⓜ | 1 | 9 | 9 | . | 9 | 9 | 9 | m | O | H | M | , |
| ① | | ② | | ③ | | | | | | | | | | ④ | | | | | | | | | | ⑥ |

| | | | | | | | | | | | | | | |
|---|---|---|---|---|---|---|---|---|---|---|---|---|---|---|
| 2 | 2 | 2 | 2 | 3 | 3 | 3 | 3 | 3 | 3 | 3 | 3 | 3 | 3 | 3 |
| 6 | 7 | 8 | 9 | 0 | 1 | 2 | 3 | 4 | 5 | 6 | 7 | 8 | 9 | |
| Ⓜ | Ⓜ | Ⓜ | 1 | 0 | 0 | . | 0 | Ⓜ | Ⓜ | % | Ⓜ | C | L | |
| | | | | | | | | | | | | R | F | |
| ⑤ | | | | | | | | | | | | ⑦ | | |

- ⓪ : Equipment no.
- Ⓛ : Exit code
- Ⓜ : Ratio setting
- Ⓛ : Standard resistance value (Rs)
- Ⓜ : Deviation setting value
- Ⓛ : Punctuation
- Ⓜ : Delimiter (CR+LF)

Note Ⓜ : Space (20H)

5.7.13 RATIOSTD= ... Ratio setting

When function is OHM RATIO and TC RATIO, standard resistance value and deviation are set.

| | | | | | | | | | | | | | | | | | | | | | | | |
|---|---|---|---|---|---|---|---|---|---|---|---|---|---|---|---|---|---|---|---|---|---|---|---|
| 0 | 0 | 0 | 0 | 0 | 0 | 0 | 0 | 1 | 1 | 1 | 1 | 1 | 1 | 1 | 1 | 1 | 1 | 2 | 2 | 2 | 2 | 2 | 2 |
| 1 | 2 | 4 | 5 | 6 | 7 | 8 | 9 | 0 | 1 | 2 | 3 | 4 | 5 | 6 | 7 | 8 | 9 | 0 | 1 | 2 | 3 | 4 | 5 |
| 0 | 1 | R | A | T | I | O | S | T | D | = | Ⓢ | 1 | 9 | 9 | . | 9 | 9 | 9 | m | O | H | M | , |
| ① | | ② | | | | | | | | | | ③ | | | | | | | | | | ⑤ | |

| | | | | | | | | | | | | | | | |
|---|---|---|---|---|---|---|---|---|---|---|---|---|---|---|---|
| 2 | 2 | 2 | 2 | 3 | 3 | 3 | 3 | 3 | 3 | 3 | 3 | 3 | 3 | 3 | |
| 6 | 7 | 8 | 9 | 0 | 1 | 2 | 3 | 4 | 5 | 6 | 7 | 8 | 9 | | |
| Ⓢ | Ⓢ | Ⓢ | 1 | 0 | 0 | . | 0 | Ⓢ | Ⓢ | % | Ⓢ | C | L | | |
| ④ | | | | | | | | | | | | Ⓢ | R | F | ⑥ |

Ⓢ : Equipment no.

Ⓢ : Ratio setting

Ⓢ : Standard resistance value setting

| | | | | | | | | | | | | |
|---|---|---|---|---|---|---|---|---|---|---|---|---|
| Ⓢ | 2 | 0 | . | 0 | 0 | 0 | 0 | m | O | H | M | Standard resistance value 30mΩ is set in range 20.000mΩ |
| Ⓢ | 2 | . | 0 | 0 | 0 | 0 | 0 | Ⓢ | O | H | M | Standard resistance value 3Ω is set in range 2.00000Ω |

Ⓢ : Deviation setting

| | | | | | | | | | | | | |
|---|---|---|---|---|---|---|---|---|---|---|---|---------------------|
| Ⓢ | Ⓢ | Ⓢ | 1 | 0 | 0 | . | 0 | Ⓢ | Ⓢ | % | Ⓢ | Ratio range 100.0 % |
| Ⓢ | Ⓢ | Ⓢ | Ⓢ | 1 | 5 | . | 3 | Ⓢ | Ⓢ | % | Ⓢ | Ratio range 15.3 % |

Ⓢ : Punctuation

Ⓢ : Delimiter (CR+LF)

Note) Ⓢ : Space (20H)

5.7.14 MEM? ... Read out of memory no.

Request of read out

| | | | | | | | | |
|---|---|---|---|---|---|---|---|---|
| 0 | 0 | 0 | 0 | 0 | 0 | 0 | 0 | 0 |
| 1 | 2 | 3 | 4 | 5 | 6 | 7 | 8 | |
| 0 | 1 | M | E | M | ? | C | L | |
| | | | | | | R | F | |
| ① | ② | | | | | ③ | | |

⓪: Equipment no.

Ⓛ: Request command of memory no. (MEM?) being displayed

Ⓞ: Delimiter (CR+LF)

Response

| | | | | | | | | | | | | | |
|---|---|---|---|---|---|---|---|---|---|---|---|---|---|
| 0 | 0 | 0 | 0 | 0 | 0 | 0 | 0 | 0 | 1 | 1 | 1 | 1 | 1 |
| 1 | 2 | 3 | 4 | 5 | 6 | 7 | 8 | 9 | 0 | 1 | 2 | 3 | 4 |
| 0 | 1 | A | M | E | M | = | N | o | . | 0 | 9 | C | L |
| | | | | | | | | | | | | R | F |
| ① | ② | ③ | | | | | | | | | ④ | | |

⓪: Equipment no.

Ⓛ: Exit code

Ⓞ: Memory no. (01~30)

Ⓞ: Delimiter (CR+LF)

5.7.15 MEM=CALL ... Switching of memory no.

Memory no. switching

| | | | | | | | | | | | | | |
|---|---|---|---|---|---|---|---|---|---|---|---|---|---|
| 0 | 0 | 0 | 0 | 0 | 0 | 0 | 0 | 0 | 1 | 1 | 1 | 1 | 1 |
| 1 | 2 | 3 | 4 | 5 | 6 | 7 | 8 | 9 | 0 | 1 | 2 | 3 | 4 |
| 0 | 1 | M | E | M | = | C | A | L | L | 0 | 1 | C | L |
| | | | | | | | | | | | | R | F |
| ① | ② | | | | | | | | | | ③ | | |

⓪: Equipment no.

Ⓛ: Memory no. switching command (MEM=CALL)

Memory no. 01~30

Ⓞ: Delimiter (CR+LF)

Response

| | | | | |
|---|---|---|---|---|
| 0 | 0 | 0 | 0 | 0 |
| 1 | 2 | 3 | 4 | 5 |
| 0 | 1 | A | C | L |
| | | | R | F |
| ① | ② | ③ | | |

⓪: Equipment no.

Ⓛ: Exit code

Ⓞ: Delimiter (CR+LF)

5.7.16 MEM01? ... Read out of memory setting contents

Request of the read out

| | | | | | | | | | | | |
|---|---|---|---|---|---|---|---|---|---|---|--|
| 0 | 0 | 0 | 0 | 0 | 0 | 0 | 0 | 0 | 0 | 1 | |
| 1 | 2 | 3 | 4 | 5 | 6 | 7 | 8 | 9 | 0 | | |
| 0 | 1 | M | E | M | 0 | 1 | ? | C | L | | |
| | | | | | | | | R | F | | |
| ① | | ② | | | | | | ③ | | | |

- ⓪: Equipment no.
- Ⓛ: Read out command of memory setting contents (MEM□□?)
□□: Memory no.01~30
- Ⓜ: Delimiter (CR+LF)

Response

| | | | | | | | | | | | | | | | | | | | | | | |
|---|---|---|---|---|---|---|---|---|---|---|---|---|---|---|---|---|---|---|---|---|---|---|
| 0 | 0 | 0 | 0 | 0 | 0 | 0 | 0 | 0 | 0 | 1 | 1 | 1 | 1 | 1 | 1 | 1 | 1 | 2 | 2 | 2 | 2 | |
| 1 | 2 | 3 | 4 | 5 | 6 | 7 | 8 | 9 | 0 | 1 | 2 | 3 | 4 | 5 | 6 | 7 | 8 | 9 | 0 | 1 | 2 | 3 |
| 0 | 1 | A | M | E | M | = | N | o | . | 1 | 9 | , | O | H | M | Ⓢ | Ⓢ | Ⓢ | Ⓢ | Ⓢ | Ⓢ | , |
| ① | | ② | | ③ | | | ④ | | | | | ⑤ | | ⑥ | | | | | ⑦ | | | |

| | | | | | | | |
|---|---|---|---|---|---|---|---|
| 2 | 2 | 2 | 2 | 2 | 2 | 3 | 3 |
| 4 | 5 | 6 | 7 | 8 | 9 | 0 | 1 |
| 3 | 0 | 0 | m | O | H | M | , |
| ⑧ | | | | | | | ⑨ |

| | | | | | | | | | | | | | |
|---|---|---|---|---|---|---|---|---|---|---|---|---|---|
| 3 | 3 | 3 | 3 | 3 | 3 | 3 | 3 | 4 | 4 | 4 | 4 | 4 | 4 |
| 2 | 3 | 4 | 5 | 6 | 7 | 8 | 9 | 0 | 1 | 2 | 3 | 4 | 5 |
| H | Ⓢ | 3 | 0 | 0 | . | 0 | 0 | 0 | m | O | H | M | , |
| ⑩ | | | | | | | | | | | | ⑪ | |

| | | | | | | | | | | | | | | |
|---|---|---|---|---|---|---|---|---|---|---|---|---|---|---|
| 4 | 4 | 4 | 4 | 5 | 5 | 5 | 5 | 5 | 5 | 5 | 5 | 5 | 5 | 6 |
| 6 | 7 | 8 | 9 | 0 | 1 | 2 | 3 | 4 | 5 | 6 | 7 | 7 | 9 | 0 |
| L | Ⓢ | 1 | 0 | 0 | . | 0 | 0 | 0 | m | O | H | M | C | L |
| | | | | | | | | | | | | | R | F |
| ⑫ | | | | | | | | | | | | | ⑬ | |

- ⓪: Equipment no.
- Ⓛ: Exit code
- Ⓜ: Read out of memory setting contents
- Ⓛ: Memory no. (No.01~No.30)
- Ⓜ: Measurement function (5.7.2 Refer [Read out of function])
- Ⓛ: Measurement range (5.7.4 Refer [Read out of measurement range])
- Ⓜ: HIGH setting (5.7.11 Refer [Comparator setting])
- Ⓛ: LOW setting (5.7.11 Refer [Comparator setting])
- Ⓜ: Punctuation
- Ⓛ: Delimiter (CR+LF)

5.7.17 WRITE MEMORY ... Storage of memory

The setting value transmitted with communication is memorized in the non-volatile memory.

| | | | | | | | | | | | | | | | | |
|---|---|---|---|---|---|---|---|---|---|---|---|---|---|---|---|---|
| 0 | 0 | 0 | 0 | 0 | 0 | 0 | 0 | 0 | 1 | 1 | 1 | 1 | 1 | 1 | 1 | 1 |
| 1 | 2 | 3 | 4 | 5 | 6 | 7 | 8 | 9 | 0 | 1 | 2 | 3 | 4 | 5 | 6 | |
| 0 | 1 | W | R | I | T | E | Ⓢ | M | E | M | O | R | Y | C | L | |
| | | | | | | | | | | | | | | R | F | |
| ① | | ② | | | | | | | | | | | | ③ | | |

- Ⓢ : Equipment no.
- Ⓢ : Memory storage
- Ⓢ : Delimiter (CR+LF)
- Note)** Ⓢ : Space (20H)

Response

| | | | | |
|---|---|---|---|---|
| 0 | 0 | 0 | 0 | 0 |
| 1 | 2 | 3 | 4 | 5 |
| 0 | 1 | A | C | L |
| | | | R | F |
| ① | ② | ③ | | |

- Ⓢ : Equipment no.
- Ⓢ : Exit code
- Ⓢ : Delimiter (CR+LF)

5.7.18 ONLINE? ... Read out of online status

Request of read out

| | | | | | | | | | | | |
|---|---|---|---|---|---|---|---|---|---|---|---|
| 0 | 0 | 0 | 0 | 0 | 0 | 0 | 0 | 0 | 0 | 1 | 1 |
| 1 | 2 | 3 | 4 | 5 | 6 | 7 | 8 | 9 | 0 | 0 | 1 |
| 0 | 1 | O | N | L | I | N | E | ? | C | L | |
| | | | | | | | | | R | F | |
| ① | | ② | | | | | | | ③ | | |

- ⓪: Equipment no.
- Ⓛ: Online state request command (ONLINE?)
- Ⓜ: Delimiter (CR+LF)

Response

| | | | | | | | | | | | | | | | |
|---|---|---|---|---|---|---|---|---|---|---|---|---|---|---|---|
| 0 | 0 | 0 | 0 | 0 | 0 | 0 | 0 | 0 | 0 | 1 | 1 | 1 | 1 | 1 | 1 |
| 1 | 2 | 3 | 4 | 5 | 6 | 7 | 8 | 9 | 0 | 1 | 2 | 3 | 4 | 5 | |
| 0 | 1 | A | O | N | L | I | N | E | = | O | N | Ⓜ | C | L | |
| | | | | | | | | | | | | | R | F | |
| ① | | ② | | ③ | | | | | | | | | ④ | | |

- ⓪: Equipment no.
- Ⓛ: Exit code
- Ⓜ: Online state

| | | | | | | | | | | |
|---|---|---|---|---|---|---|---|---|---|-----|
| O | N | L | I | N | E | = | O | N | Ⓜ | ON |
| O | N | L | I | N | E | = | O | F | F | OFF |

- Ⓜ: Delimiter (CR+LF)
- Note)** Ⓜ: Space (20H)

5.7.19 ONLINE= ... Setting of online

Online setting

| | | | | | | | | | | | | | | |
|---|---|---|---|---|---|---|---|---|---|---|---|---|---|---|
| 0 | 0 | 0 | 0 | 0 | 0 | 0 | 0 | 0 | 0 | 1 | 1 | 1 | 1 | 1 |
| 1 | 2 | 3 | 4 | 5 | 6 | 7 | 8 | 9 | 0 | 1 | 2 | 3 | 4 | |
| 0 | 1 | O | N | L | I | N | E | = | O | N | Ⓜ | C | L | |
| | | | | | | | | | | | | R | F | |
| ① | | ② | | | | | | | | | ③ | | | |

- ⓪: Equipment no.
- Ⓛ: Online setting

| | | | | | | | | | | |
|---|---|---|---|---|---|---|---|---|---|-----|
| O | N | L | I | N | E | = | O | N | Ⓜ | ON |
| O | N | L | I | N | E | = | O | F | F | OFF |

- Ⓜ: Delimiter (CR+LF)
- Note)** Ⓜ: Space (20H)

Response

| | | | | |
|---|---|---|---|---|
| 0 | 0 | 0 | 0 | 0 |
| 1 | 2 | 3 | 4 | 5 |
| 0 | 1 | A | C | L |
| | | | R | F |
| ① | | ② | | ③ |

- ⓪: Equipment no.
- Ⓛ: Exit code
- Ⓜ: Delimiter (CR+LF)

Note) ONLINE is possible to switch ON/OFF even with key operation. In case of operation of setting ONLINE with communication, it is recommended for communication with key-lock ON.

5.7.20 HOLD? ... Read out of HOLD state

Request of read out

| | | | | | | | | | | |
|---|---|---|---|---|---|---|---|---|---|--|
| 0 | 0 | 0 | 0 | 0 | 0 | 0 | 0 | 0 | 0 | |
| 1 | 2 | 3 | 4 | 5 | 6 | 7 | 8 | 9 | | |
| 0 | 1 | H | O | L | D | ? | C | L | | |
| | | | | | | | R | F | | |
| ① | | ② | | | | | ③ | | | |

- ①: Equipment no.
- ②: HOLD state request command (HOLD?)
- ③: Delimiter (CR+LF)

Response

| | | | | | | | | | | | | |
|---|---|---|---|---|---|---|---|---|---|---|---|---|
| 0 | 0 | 0 | 0 | 0 | 0 | 0 | 0 | 0 | 1 | 1 | 1 | 1 |
| 1 | 2 | 3 | 4 | 5 | 6 | 7 | 8 | 9 | 0 | 1 | 2 | 3 |
| 0 | 1 | A | H | O | L | D | = | O | N | ␣ | C | L |
| | | | | | | | | | | | R | F |
| ① | | ② | | ③ | | | | | | | ④ | |

- ①: Equipment no.
- ②: Exit code
- ③: State of HOLD

| | | | | | | | | |
|---|---|---|---|---|---|---|---|-----|
| H | O | L | D | = | O | N | ␣ | ON |
| H | O | L | D | = | O | F | F | OFF |

- ④: Delimiter (CR+LF)
- Note)** ␣: Space (20H)

5.7.21 HOLD= ... Setting of HOLD

HOLD setting

| | | | | | | | | | | | |
|---|---|---|---|---|---|---|---|---|---|---|---|
| 0 | 0 | 0 | 0 | 0 | 0 | 0 | 0 | 1 | 1 | 1 | |
| 1 | 2 | 3 | 4 | 5 | 6 | 7 | 8 | 9 | 0 | 1 | 2 |
| 0 | 1 | H | O | L | D | = | O | N | ␣ | C | L |
| | | | | | | | | | | R | F |
| ① | | ② | | | | | | | | ③ | |

- ①: Equipment no.
- ②: HOLD setting

| | | | | | | | | |
|---|---|---|---|---|---|---|---|-----|
| H | O | L | D | = | O | N | ␣ | ON |
| H | O | L | D | = | O | F | F | OFF |

- ③: Delimiter (CR+LF)
- Note)** ␣: Space (20H)

Response

| | | | | |
|---|---|---|---|---|
| 0 | 0 | 0 | 0 | 0 |
| 1 | 2 | 3 | 4 | 5 |
| 0 | 1 | A | C | L |
| | | | R | F |
| ① | | ② | | ③ |

- ①: Equipment no.
- ②: Exit code
- ③: Delimiter (CR+LF)

5.7.22 RST? ... Read out of reset state

Request of read out

| | | | | | | | |
|---|---|---|---|---|---|---|---|
| 0 | 0 | 0 | 0 | 0 | 0 | 0 | 0 |
| 1 | 2 | 3 | 4 | 5 | 6 | 7 | 8 |
| 0 | 1 | R | S | T | ? | C | L |
| | | | | | | R | F |
| ① | | ② | | | | ③ | |

- ①: Equipment no.
- ②: Reset state request command (RST?)
- ③: Delimiter (CR+LF)

Response

| | | | | | | | | | | | |
|---|---|---|---|---|---|---|---|---|---|---|---|
| 0 | 0 | 0 | 0 | 0 | 0 | 0 | 0 | 0 | 1 | 1 | 1 |
| 1 | 2 | 3 | 4 | 5 | 6 | 7 | 8 | 9 | 0 | 1 | 2 |
| 0 | 1 | A | R | S | T | = | O | N | ␣ | C | L |
| | | | | | | | | | | R | F |
| ① | | ② | | ③ | | | | | | ④ | |

- ①: Equipment no.
- ②: Exit code
- ③: State of reset

| | | | | | | | |
|---|---|---|---|---|---|---|-----|
| R | S | T | = | O | N | ␣ | ON |
| R | S | T | = | O | F | F | OFF |

- ④: Delimiter (CR+LF)

Note ␣: Space (20H)

5.7.23 RST= ... Setting of reset

Setting of reset

| | | | | | | | | | | |
|---|---|---|---|---|---|---|---|---|---|---|
| 0 | 0 | 0 | 0 | 0 | 0 | 0 | 0 | 0 | 1 | 1 |
| 1 | 2 | 3 | 4 | 5 | 6 | 7 | 8 | 9 | 0 | 1 |
| 0 | 1 | R | S | T | = | O | N | ␣ | C | L |
| | | | | | | | | | R | F |
| ① | | ② | | | | | | | ③ | |

- ①: Equipment no.
- ②: Setting of reset

| | | | | | | | |
|---|---|---|---|---|---|---|-----|
| R | S | T | = | O | N | ␣ | ON |
| R | S | T | = | O | F | F | OFF |

- ③: Delimiter (CR+LF)

Note ␣: Space (20H)

Response

| | | | | |
|---|---|---|---|---|
| 0 | 0 | 0 | 0 | 0 |
| 1 | 2 | 3 | 4 | 5 |
| 0 | 1 | A | C | L |
| | | R | F | |
| ① | | ② | | ③ |

- ①: Equipment no.
- ②: Exit code
- ③: Delimiter (CR+LF)

5.7.24 ZEROADJ? ... Read out of zero adjustment state

Request of read out

| | | | | | | | | | | | | |
|---|---|---|---|---|---|---|---|---|---|---|---|---|
| 0 | 0 | 0 | 0 | 0 | 0 | 0 | 0 | 0 | 0 | 1 | 1 | 1 |
| 1 | 2 | 3 | 4 | 5 | 6 | 7 | 8 | 9 | 0 | 1 | 2 | |
| 0 | 1 | Z | E | R | O | A | D | J | ? | C | L | |
| | | | | | | | | | | R | F | |
| ① | ② | | | | | | | | | ③ | | |

- ①: Equipment no.
- ②: Zero adjustment state request command (ZEROADJ?)
- ③: Delimiter (CR+LF)

Response

| | | | | | | | | | | | | | | | |
|---|---|---|---|---|---|---|---|---|---|---|---|---|---|---|---|
| 0 | 0 | 0 | 0 | 0 | 0 | 0 | 0 | 0 | 0 | 1 | 1 | 1 | 1 | 1 | 1 |
| 1 | 2 | 3 | 4 | 5 | 6 | 7 | 8 | 9 | 0 | 1 | 2 | 3 | 4 | 5 | 6 |
| 0 | 1 | A | Z | E | R | O | A | D | J | = | O | N | ␣ | C | L |
| | | | | | | | | | | | | | | R | F |
| ① | ② | ③ | | | | | | | | | | ④ | | | |

- ①: Equipment no.
- ②: Exit code
- ③: State of zero adjustment

| | | | | | | | | | | | |
|---|---|---|---|---|---|---|---|---|---|---|-----|
| Z | E | R | O | A | D | J | = | O | N | ␣ | ON |
| Z | E | R | O | A | D | J | = | O | F | F | OFF |

- ④: Delimiter (CR+LF)

Note) ␣: Space (20H)

5.7.25 ZEROADJ= ... Setting of zero adjustment

Setting of zero adjustment

| | | | | | | | | | | | | | | |
|---|---|---|---|---|---|---|---|---|---|---|---|---|---|---|
| 0 | 0 | 0 | 0 | 0 | 0 | 0 | 0 | 0 | 0 | 1 | 1 | 1 | 1 | 1 |
| 1 | 2 | 3 | 4 | 5 | 6 | 7 | 8 | 9 | 0 | 1 | 2 | 3 | 4 | 5 |
| 0 | 1 | Z | E | R | O | A | D | J | = | O | N | ␣ | C | L |
| | | | | | | | | | | | | | R | F |
| ① | ② | | | | | | | | | | ③ | | | |

- ①: Equipment no.
- ②: Zero adjustment setting

| | | | | | | | | | | | |
|---|---|---|---|---|---|---|---|---|---|---|-----|
| Z | E | R | O | A | D | J | = | O | N | ␣ | ON |
| Z | E | R | O | A | D | J | = | O | F | F | OFF |

- ③: Delimiter (CR+LF)

Note) ␣: Space (20H)

Response

| | | | | |
|---|---|---|---|---|
| 0 | 0 | 0 | 0 | 0 |
| 1 | 2 | 3 | 4 | 5 |
| 0 | 1 | A | C | L |
| | | | R | F |
| ① | ② | ③ | | |

- ①: Equipment no.
- ②: Exit code
- ③: Delimiter (CR+LF)

5.7.26 READ ... Sampling data output

Sampling is performed once and measurement data is output if READ command is received under sampling hold.

| | | | | | | | |
|---|---|---|---|---|---|---|---|
| 0 | 0 | 0 | 0 | 0 | 0 | 0 | 0 |
| 1 | 2 | 3 | 4 | 5 | 6 | 7 | 8 |
| 0 | 1 | R | E | A | D | C | L |
| | | | | | | R | F |
| ① | | ② | | | | ③ | |

- ① : Equipment no.
- ② : Sampling data output command (READ)
- ③ : Delimiter (CR+LF)

Response A

| | | | | |
|---|---|---|---|---|
| 0 | 0 | 0 | 0 | 0 |
| 1 | 2 | 3 | 4 | 5 |
| 0 | 1 | A | C | L |
| | | | R | F |
| ① | | ② | ③ | |

- ① : Equipment no.
- ② : Exit code
 - During ONLINE OFF: Exit code F
 - During HOLD OFF: Exit code C
- ③ : Delimiter (CR+LF)

Response B

Refer response of "5.7.1 DATA?...Read out of measurement data"

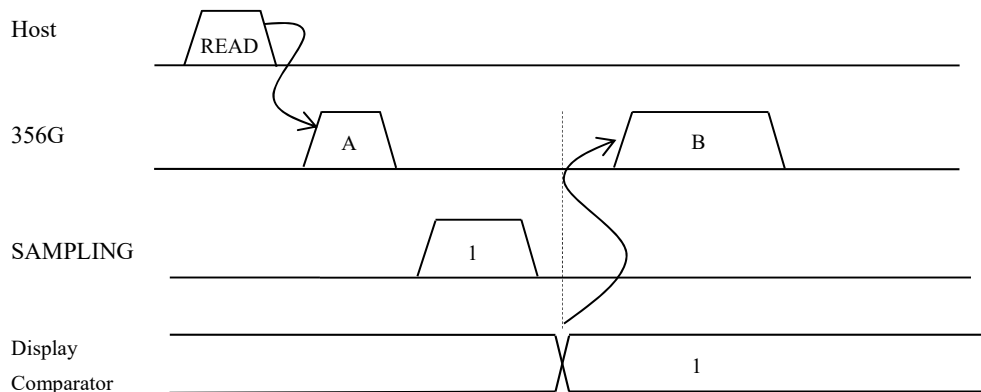

- A : A response code corresponding to READ is output.
- B : Measured data is output once after end of sampling.

6. Analog output

The voltage of 0~3V is output in the resistance or temperature corrector value.

6.1●Output specifications

| | |
|----------------------|--|
| Output | Full scale: 3V, Load resistance: More than 2kΩ Output is done corresponding to resistance display or correction resistance value. |
| Output voltage range | 0.0~3.5V When minus display: 0.0V When over display: During OHM and OHM-RATIO: 3.5V During TC and TC-RATIO: Maximum 4.0V (Over value) |
| Conversion method | D/A conversion method |
| Accuracy | One year accuracy ±0.2% F.S (Defined by the range of 0V~3V) |
| Output data | During OHM and TEMP: Output resistance measurement value During T.C: Output Correction resistance value (display value) |
| Output cycle | Renewed with display cycle |
| Response time | Time for the output to enter within the accuracy after renewed of the display: Less than 3ms |
| Resolution | 1/30000 |

| Range | Display | Analog output | Range | Display | Analog output |
|-------|------------|---------------|-------|------------|---------------|
| 30mΩ | 0.0000 mΩ | 0.0000 V | 300mΩ | 0.000 mΩ | 0.0000 V |
| | 10.0000 mΩ | 1.0000 V | | 100.000 mΩ | 1.0000 V |
| | 24.9999 mΩ | 2.4999 V | | 249.999 mΩ | 2.4999 V |
| | 30.0000 mΩ | 3.0000 V | | 300.000 mΩ | 3.0000 V |
| | 35.0000 mΩ | 3.5000 V | | 350.000 mΩ | 3.5000 V |
| | OVER | 3.5000 V | | OVER | 3.5000 V |
| 3Ω | 0.00000 Ω | 0.0000 V | 30 Ω | 0.0000 Ω | 0.0000 V |
| | 1.00000 Ω | 1.0000 V | | 10.0000 Ω | 1.0000 V |
| | 2.49999 Ω | 2.4999 V | | 24.9999 Ω | 2.4999 V |
| | 3.00000 Ω | 3.0000 V | | 30.0000 Ω | 3.0000 V |
| | 3.50000 Ω | 3.5000 V | | 35.0000 Ω | 3.5000 V |
| | OVER | 3.5000 V | | OVER | 3.5000 V |
| 300 Ω | 0.000 Ω | 0.0000 V | | | |
| | 100.000 Ω | 1.0000 V | | | |
| | 249.999 Ω | 2.4999 V | | | |
| | 300.000 Ω | 3.0000 V | | | |
| | 350.000 Ω | 3.5000 V | | | |
| | OVER | 3.5000 V | | | |

When display is below 0 due to zero adjustment function etc., output is 0.0000V.

In case of temperature correction, the correction resistance value calculated exceeds 350000 and is calculated maximum till 399999. In this case analog output is output maximum 4.000V together with the display.

Measurement function and output data

| FUNCTION | Analog output |
|-----------|--|
| TRMP | Resistance measurement value (OHM) |
| OHM | Resistance measurement value (OHM) |
| OHM RATIO | Resistance measurement value (OHM) |
| TC | Correction value resistance value (TC) |
| TC RATIO | Correction value resistance value (TC) |

7. BCD output

The measurement data of 356G is output with BCD data.

7.1●Output specifications

7.1.1 TTL output (-03)

BCD data is output with TTL level.

Output method : BCD parallel code Positive logic

Output "L" level with logic "0" Output "H" level with logic "1"

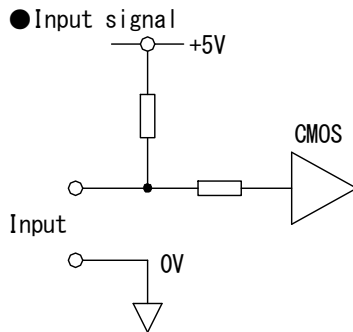

Input level : $I_{IL} \leq -1\text{mA}$
"L" = Less than 0.8V
"H" = 3.5~5V

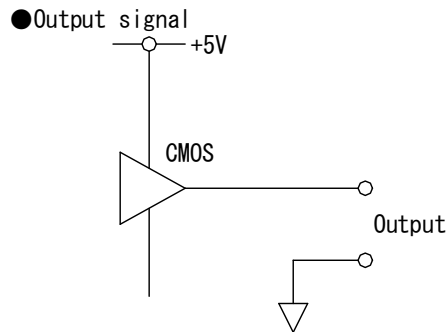

Output level : TTL level
 $I_{oh} = 4\text{mA}$
 $I_{ol} = -4\text{mA}$

7.1.2 Open collector output (-04)

BCD data is output with open collector.

Output method: BCD parallel code

Output "OFF" with logic "0" Output "ON" with logic "1"

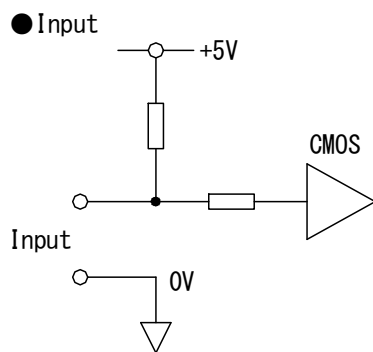

Input level : $I_{IL} \leq -1\text{mA}$
"L" = Less than 1.5V
"H" = 3.5~5V

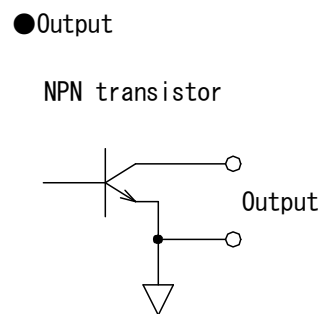

Output capacity : DC30V, 30mA

7.2●Connector pin array

| Signal name | | № | № | Signal name | |
|---------------|---|----|----|------------------------|-----------------------|
| $\times 10^0$ | 1 | 1 | 19 | 1 | $\times 10^1$ |
| | 2 | 2 | 20 | 2 | |
| | 4 | 3 | 21 | 4 | |
| | 8 | 4 | 22 | 8 | |
| $\times 10^2$ | 1 | 5 | 23 | 1 | $\times 10^3$ |
| | 2 | 6 | 24 | 2 | |
| | 4 | 7 | 25 | 4 | |
| | 8 | 8 | 26 | 8 | |
| $\times 10^4$ | 1 | 9 | 27 | 1 | $\times 10^5$ |
| | 2 | 10 | 28 | 2 | |
| | 4 | 11 | 29 | SEL1 | Output data selection |
| | 8 | 12 | 30 | SEL2 | |
| POL (+) | | 13 | 31 | DP1 (10 ¹) | |
| OVER | | 14 | 32 | DP3 (10 ³) | |
| RANGE mΩ | | 15 | 33 | DP4 (10 ⁴) | |
| RANGE Ω | | 16 | 34 | DP5 (10 ⁵) | |
| STROBE | | 17 | 35 | ENABLE | |
| COM | | 18 | 36 | COM | |

Connector in use: Amphenol 36 pin

7.3●Descriptions of input and output signals

7.3.1 Output signal

Measurement data output: 1,2,4,8 ($\times 10^0 \sim \times 10^5$)

Measurement data is output with parallel BCD code.

Note) During F sampling, 10^0 outputs 0.

Decimal point output

Decimal point corresponding with measurement range is output with code.

| Display | DP5 | DP4 | DP3 | DP1 |
|---------|-----|-----|-----|-----|
| 3.50000 | 0 | 1 | 1 | 1 |
| 35.0000 | 1 | 0 | 1 | 1 |
| 350.000 | 1 | 1 | 0 | 1 |
| 100.0 | 1 | 1 | 1 | 0 |

Unit output

Unit is output with code.

| Range | mΩ | Ω | % | °C |
|----------|----|---|---|----|
| RANGE mΩ | 1 | 0 | 1 | 0 |
| RANGE Ω | 0 | 1 | 1 | 0 |

7.3.2 Input signal

Data being output in BCD data are selected by SEL1 and SEL2.

Output data (SEL1,SEL2)

| | | Function | | | | |
|-------|-------|---------------|----------------|-----------------------------------|--------------------------------|--------------------------------|
| SEL 1 | SEL 2 | OHM | TEMP | TC | OHM RATIO | TC RATIO |
| H | H | Resistance *1 | Temperature *1 | Correction resistance value *1 *2 | Ratio *1 | Ratio *1 *2 |
| L | H | Resistance *1 | Temperature *1 | Resistance *1 | Resistance *1 | Correction resistance value *2 |
| H | L | Resistance *1 | Temperature *1 | Temperature *1 | Ratio *1 | Ratio *1 *2 |
| L | L | Resistance *1 | Temperature *1 | Correction resistance value *1 *2 | Standard resistance value (Rs) | Standard resistance value (Rs) |

*1 ERR 0 : When data exceeds 350000, correction resistance value is 399999 or in case the temperature range exceeds with temperature measurement, OVER becomes 1 and output is 000000 data.

*2 ERR 1 : In case measurement range exceeds the temperature measurement, OVER becomes 1 and output is 000000 data.

7.3.3 Description of signals

| Signal | Signal name | Logic (TTL) | Logic (OC) |
|------------------------|--|--|---|
| BCD data | $\times 10^0, \times 10^1, \times 10^2, \times 10^3, \times 10^4,$ | Positive logic 1 :H (3.5~5V) 0 :L (Less than 0.8) | Positive logic 1 :Tr ON 0 :Tr OFF |
| Decimal point | DP1, DP3, DP4, DP5 | Decimal point output table | |
| Sign | POL Output 1 during plus (no minus display) | Positive logic 1 :H (3.5~5V) 0 :L (Less than 0.8) | Positive logic 1 :Tr ON 0 :Tr OFF |
| Over | OVER | Positive logic 1 :H (3.5~5V) 0 :L (Less than 0.8V) | Positive logic 1 :Tr ON 0 :Tr OFF |
| Synchronization signal | SYNC | L level pulse Pulse width 1ms | Tr ON pulse Pulse width 1ms |
| Measurement range | RANGE m Ω , RANGE Ω | Range output table | |
| Data selection | SEL1, SEL2 | Range data table | |
| Enable | ENABLE | H (3.5~5V) : Enable L (Less than 0.8V) : Disable Output during disable TTL: Total output data Hi-Z OC : Total output data Tr OFF | |

7.4●Timing chart

Start delay=0, Average count=1time

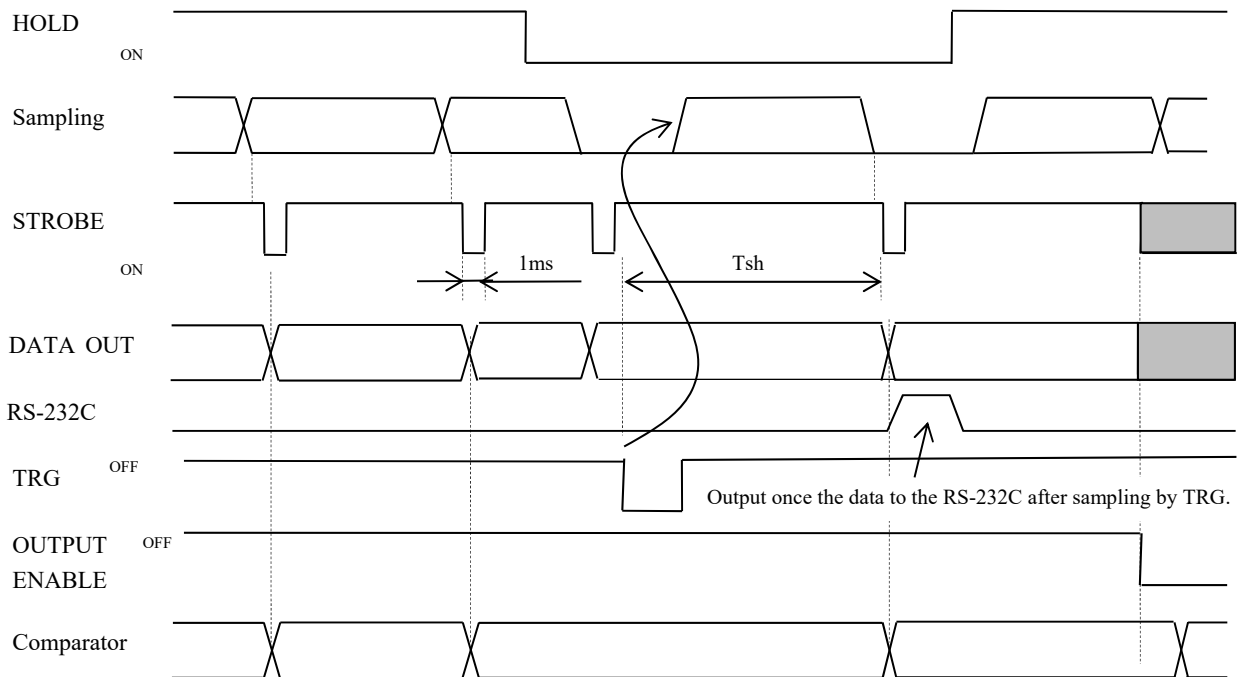

Tsh : Sampling rate+Processing time

■ : Hi Impedance

Processing time

Offset voltage correction function OFF

Average count×0.1ms+3ms

Offset voltage correction function ON

Average count×0.1ms+6ms

When the range is changed during HOLD, 15ms of range switching time will be added.

Data select timing chart

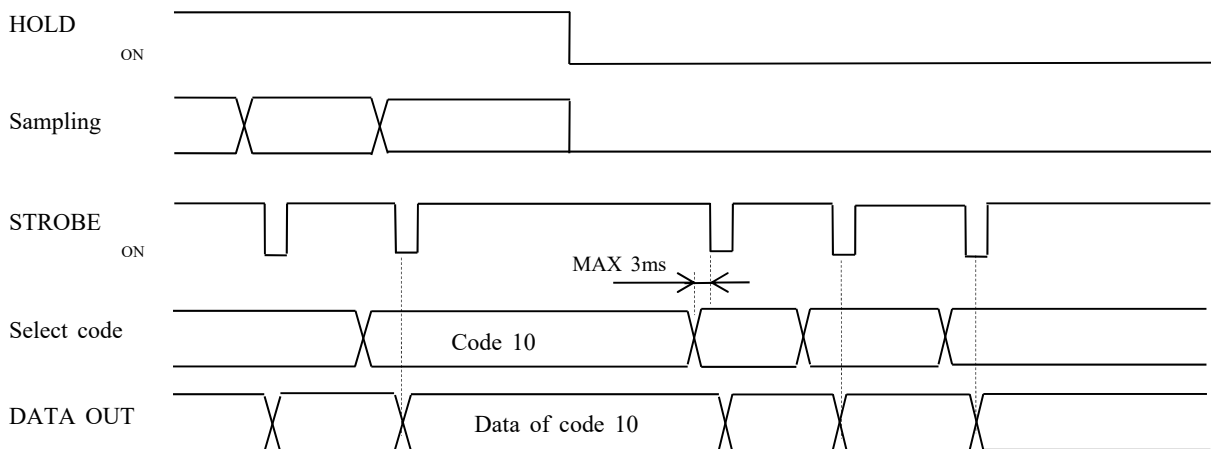

If the select code is changed during sampling, the data after the end of the sampling will be affected.
If select code is changed during HOLD, output will change corresponding to the change in the code.

8. Calibration

8.1 Things needed for preparation

Prepare the calibration equipment like below.

Standard resistance for resistance measurement range calibration: 30mΩ, 300mΩ, 3Ω, 30Ω, 300Ω

8.2 Calibration method

8.2.1 Calibration of resistance measurement range

Apply power while holding down **FUNC** key and **SHIFT** key.

The screen becomes "Calibration mode" if it is pressed continuously more than 1 second.

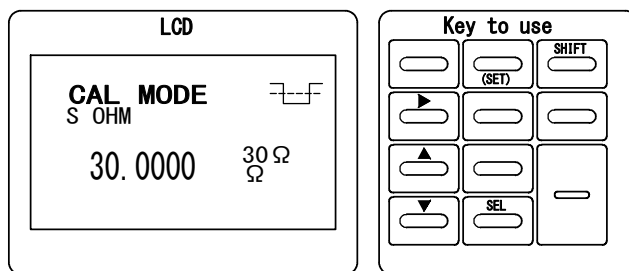

When **FUNC** key is pressed, the switching over of resistance measurement/temperature/ analog output calibration is done. Resistance measurement (OHM) is selected.

Resistance calibration

When **RANGE** key is pressed, the switching over of the range of resistance measurement is done.

Calibration of each range of 30mΩ/ 300mΩ/ 3Ω/ 30Ω/ 300Ω

When **▶** key is pressed, ZERO calibration value is memorized.

When **▲** key is pressed, MAX calibration value is memorized.

| Range | Standard resistance value | ZERO display value | MAX display value |
|-------|---------------------------|--------------------|-------------------|
| 30 mΩ | 30mΩ | 0.0000mΩ | 30.0000mΩ |
| 300mΩ | 300mΩ | 0.000mΩ | 300.000mΩ |
| 3 Ω | 3 Ω | 0.00000 Ω | 3.00000 Ω |
| 30 Ω | 30 Ω | 0.0000 Ω | 30.0000 Ω |
| 300 Ω | 300 Ω | 0.000 Ω | 300.000 Ω |

Connection during calibration

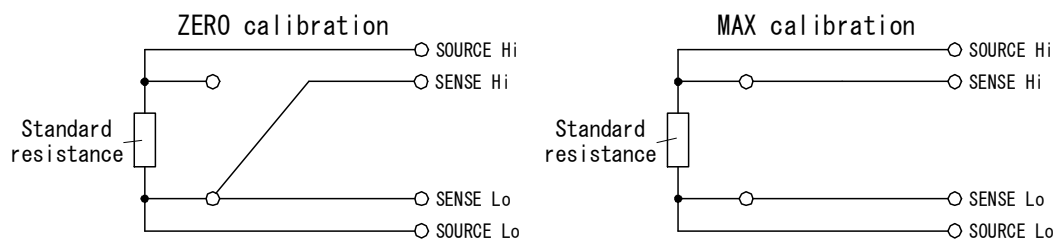

End

Power is put off.

8.2.2 Calibration of temperature

Apply power while holding down **FUNC** key and **SHIFT** key.

The screen becomes "Calibration mode" if it is pressed continuously more than 1 second.

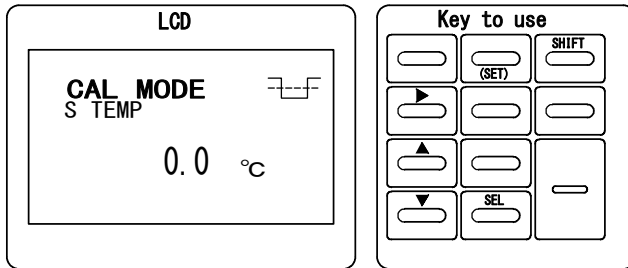

When **FUNC** key is pressed, the switching over of resistance measurement/temperature/analog output calibration is done. Temperature (TEMP) is selected.

Temperature calibration (ZERO : 0°C / MAX:190°C)

When **▶** key is pressed, ZERO calibration value is memorized.

When **▲** key is pressed, MAX calibration value is memorized.

| | Resistance value | Display value |
|------------------|------------------|---------------|
| ZERO calibration | 100.00Ω | 0.0 °C |
| MAX calibration | 172.12Ω | 190.0 °C |

Connection during calibration

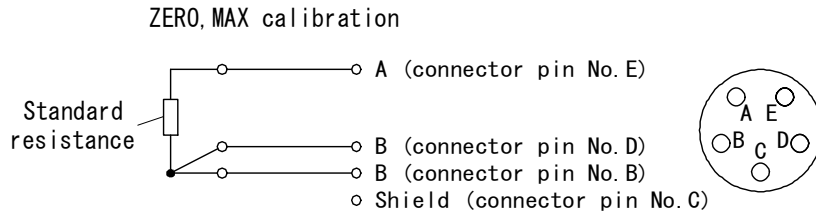

End

Power is put off.

8.2.3 Calibration of analog output

Apply power while holding down **FUNC** key and **SHIFT** key.

The screen becomes "Calibration mode" if it is pressed continuously more than 1 second.

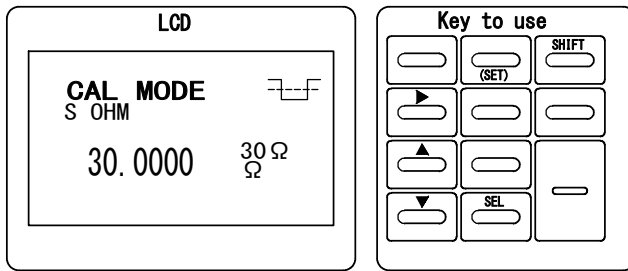

When **FUNC** key is pressed, the switching over of resistance measurement/temperature/analog output calibration is done.

When **▶** key is pressed, MAX calibration and ZERO calibration are switched over.

Output is set with **▲** **▼** keys.

The calibration value is memorized with **SEL** key.

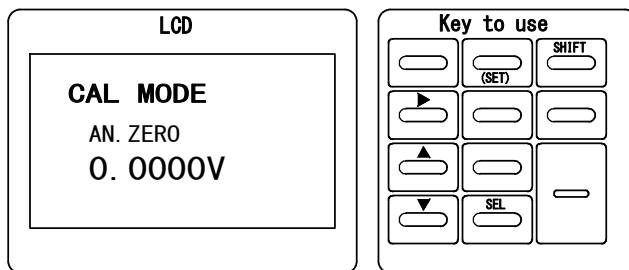

End

Power is put off.

Connection during calibration.

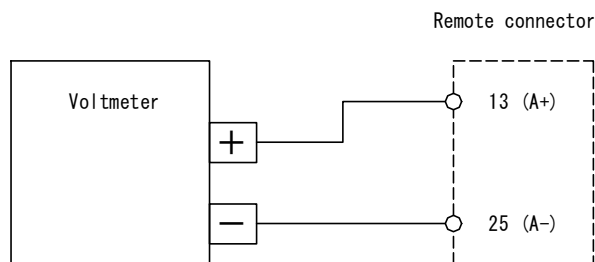

9. Specifications

9.1 Model name

| 3 5 6 G — option 1 — option 2 | option 1 | option 2 | Contents |
|-------------------------------|----------|----------|-----------------------------------|
| | X | — | No output |
| | 0 3 | — | BCD output (TTL level) |
| | 0 4 | — | BCD output (open collector level) |
| | 0 6 | — | RS-485 output |
| | | X | No analog output |
| | | 0 3 | Analog output |

9.2 Measurement range

■ Resistance measurement

During SLOW, MEDIUM sampling

| | | | | | |
|----------------------------------|-------------------------------|-------|--------------------------|-------|--------|
| Measurement range | 30mΩ | 300mΩ | 3Ω | 30Ω | 300Ω |
| Resolution | 0.1μΩ | 1μΩ | 10μΩ | 100μΩ | 1mΩ |
| Measured current | DC1A | | DC100mA | | DC10mA |
| Measured maximum applied voltage | 30mV | 300mV | | 3V | |
| Accuracy | ±(0.1% of rdg.+30digit) | | ±(0.08% of rdg.+25digit) | | |
| Temperature coefficient | ± (0.01% of rdg.+3digit) / °C | | | | |
| Open terminal voltage | DC6V Max | | | | |

※ Accuracy : Accuracy in 1 year 23°C±5°C Defined by the state of 45~75 %RH

Resistance measurement, offset voltage correction function: OFF

※ Sampling Add ±3digit in the accuracy during MEDIUM.

During FASTING sampling

| | | | | | |
|----------------------------------|-------------------------------|-------|---------|-----|--------|
| Measurement range | 30mΩ | 300mΩ | 3Ω | 30Ω | 300Ω |
| Resolution | 1μΩ | 10μΩ | 100μΩ | 1mΩ | 10mΩ |
| Measured current | DC1A | | DC100mA | | DC10mA |
| Measured maximum applied voltage | 30mV | 300mV | | 3V | |
| Accuracy | ± (0.2% of rdg.+10digit) | | | | |
| Temperature coefficient | ± (0.02% of rdg.+1digit) / °C | | | | |
| Open terminal voltage | DC6V Max | | | | |

※ Accuracy : Accuracy in 1 year 23°C±5°C Defined by the state of 45~75 %RH

Resistance measurement, offset voltage correction function: OFF

When the current limit function is on, the measurement value for the first time from the HOLD status, there is a case where the error is larger by 30Ω and 300Ω range. When the offset voltage correction function is turned on, there is a case where the error is larger by 30Ω and 300Ω range. During such case set the start delay to more than 5ms.

■ Temperature measurement

| | |
|-------------------------|--------------------------|
| Measurement range | -19.9~199.9°C |
| Resolution | 0.1°C |
| Accuracy ※ | ± (0.2% of rdg +0.2°C) |
| Temperature coefficient | ± (0.02% of rdg +0.02°C) |
| Sensor | Pt100Ω, 3-wires |
| Measured current | About 1mA |

※ Accuracy : Accuracy in 1 year 23°C±5°C Defined by the state of 45~75 %RH

9.3●General specifications

| | |
|-----------------------------------|---|
| Measurement method | 4 terminal method (Front face only) |
| Maximum allowable applied voltage | Whole range 50V DC |
| Measurement cable resistance | During measured current DC1A: Less than 2Ω Other: Less than 5Ω |
| Display | LCD display Resistance measurement : 350000 (FAST is 35000) Temperature measurement : 199.9 With zero suppression function |
| Measurement range | 30mΩ,300mΩ,3Ω,30Ω,300Ω,AUTO AUTO range Range up More than 350000 (FAST sampling More than 35000) Range down Below 30000 (FAST sampling Below 3000) |
| Over display | OVER |
| Error display | ERR-1: When FUNCTION are TC,TC RATIO and temperature measurement is over |
| CC display | CC: During resistance measurement, when SOURCE is OPEN |
| Unit display | mΩ, Ω, %, °C |
| Sampling rate | SLOW : 5 times/sec MEDIUM : 20 times/sec FAST : 80 times/sec Temperature measurement : 5times/sec |
| Noise rejection ratio | Normal mode More than 60dB (Maximum applied voltage conversion) Common mode More than 100dB (Maximum applied voltage conversion) |
| Response speed 1 | When it is connected to the specimen from input open, time till it is within the accuracy (fixed range) SLOW : About 500ms MEDIUM : About 100ms FAST : About 30ms Note: When offset correction is valid, response time becomes about two times. |
| Response speed 2 | In the state when it is connected to the specimen, when measurement is started with TRG signal during HOLD, time till the judgment output. (Fixed range, Average no. of times = 1, No start delay) SLOW : About 220ms MEDIUM : About 70ms FAST : About 30ms Note: When offset correction becomes valid, response time becomes double. |
| Insulation resistance | Supply terminal / Between outer box (FG) DC 500V More than 100MΩ Measurement terminal / Between output terminal DC 500V More than 10MΩ |
| Withstand voltage | CONTROL,RS-232C,USB / Between outer box (FG) AC 500V 1 min Supply terminal / Between outer box (FC) AC2000V 1 min |
| Parameter retention | Due to non-volatile memory, the contents due to setting by function, range, constant etc. key, are retained even when power supply is OFF. |
| Power supply | AC100~240V 50/60Hz |
| Power supply voltage range | AC 90~250V |
| Power consumption | During AC100V About 24VA During AC200V About 27VA |
| Operating ambient temperature | 0~40°C 80%RH (No condensation) |
| Storage temperature | -20~70°C 80%RH (No condensation) |
| Weight | About 2.8kg |
| Degree of protection | IP20 |
| Accessories | Power cord(3P→2P with conversion plug) 1 pc. Power fuse (spare part) 1 pc. Control input connector 1 pc. Instruction manual 1 pc. Utility software (5890-13) [with USB cable] 1 pc. |
| Option | Kelvin clip (5811-21B) Temperature sensor (5803-11) RS-232C cable (5881-11-020) |

10. Dimensions

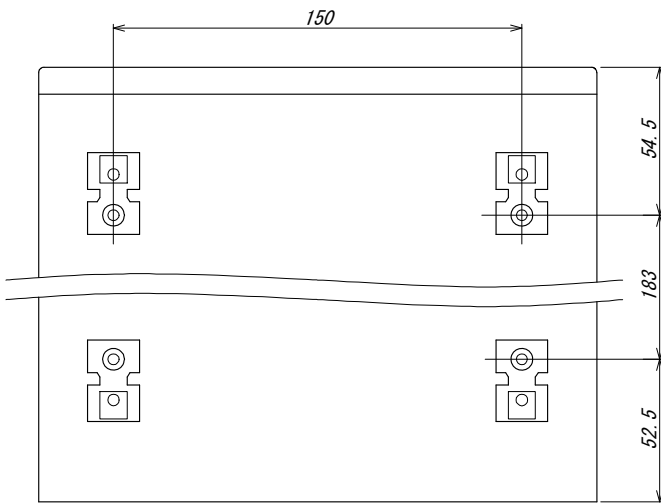
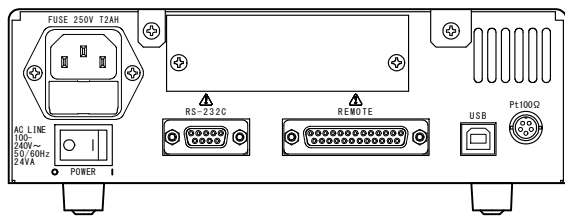
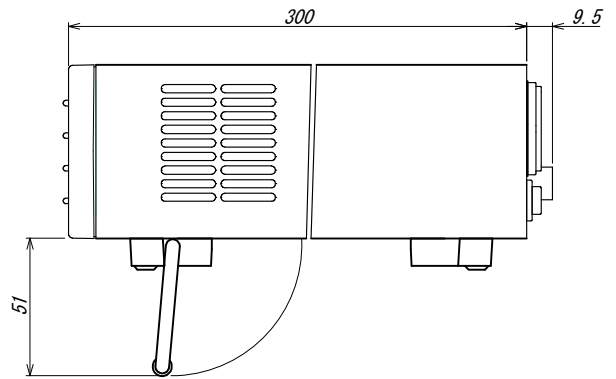
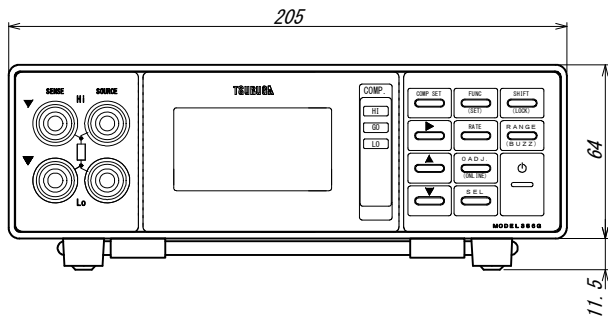

If 356G is to be fixed, fix it together with the foot with fixed screw hole of the foot.
 Recommended screw: M4×18 + thickness

11. Maintenance and calibration

11.1●Cleaning

In order to remove the dirt from this instrument, wipe lightly by a soft cloth with small amount of water and small amount of mild neutral detergent. Do not use detergent containing solvents like benzene, alcohol, paint thinner etc. It may cause deformation and decoloration.

11.2●Problem solving

In order to solve the problem, check the description in “When you think that there is a breakdown” and contact the nearest dealer or nearest sales office.

When breakdown goods are to be returned

The goods are to be packed so that it does not get damaged during transportation and write and attach the breakdown description as well. There is no guarantee for the damage during transportation.

When you think that there is a breakdown

| Conditions | Confirmation | Countermeasure |
|---|---|---|
| Power lamp is not turned on and there is no display even when the power switches turned on. | Check if the power cord is unplugged. | Plug in the power cord. |
| | Check if the power fuse is blown out. | Change the spare fuse and turn on the power supply after disconnecting the input output cables. |
| Cannot operate the keys. | Is it in the key lock state? | Release the key lock. |
| | ONLINE and EXT. are displayed and is it in external control state? | Turn off the ONLINE. Confirm the remote control and turn OFF the EXT. |
| Display value differs largely with respect to the resistance being measured | 0. ADJ is displayed and is zero adjustment turned ON? | Turn OFF the zero adjustment. |
| Measurement display does not change. | Is sampling display of S, M, F blinking? | When HOLD is ON with remote control, turn it OFF. |
| | When the sampling display is not blinking the display is not renewed. | When HOLD is ON with communication, turn it OFF. |
| Error display | | Refer error display table. |

11.3●Calibration

To maintain the accuracy for the long term, it is recommended to calibrate about every one year. For calibration, request the place where it is purchased or our sales office. However, in case some fixed time has elapsed after purchase or the production of the parts have stopped or has exceeded the guarantee time, repair and the calibration may be declined.

11.4●Error display

| Error display | Contents | Countermeasure |
|---------------------------------|--|--|
| ERR-1 | During temperature correction function, temperature measurement is over or calculation error | Confirm the temperature input. Confirm if Rs is not set to 0 with ratio display. |
| CC | SOURCE input open | Confirmation of connection state of SOURCE input terminal. Confirm if the connection resistance is not large with regards to the measurement range. |
| OHM A/D ERROR TEMP A/D ERROR | AD converter error | It is the failure of measurement circuit. Repair is requested. |
| FLASH MEMORY ERROR | ROM error | It is the failure of setting memory. Repair is requested. |

Tsuruga Electric Corporation

Osaka Headquarters

1-3-23, Minamisumiyoshi, Sumiyoshi-ku, Osaka, Japan 〒558-0041

TEL 81-6 -6692-6700, FAX 81-6 -6609- 8115

E-mail: cs.info@tsuruga.co.jp

Yokohama Office

1-29-15, Shinyokohama, Kohoku-ku, Yokohama, Kanagawa, Japan 〒222-0033

Tokyo Office

5-25-16, Higashigotanda, Shinagawa-ku, Tokyo, Japan 〒141-0022

Nagoya Office

Sun Park Higashi Betsuin Bld. 2F

5-19, Oicho, Naka-ku, Nagoya, Aichi, Japan 〒460-0015

Osaka Plant

1-3-23, Minami Sumiyoshi, Sumiyoshi-ku, Osaka, Japan 〒558-0041

Shiga Plant

122, Kawasaki-Cho, Nagahama, Shiga, Japan 〒526-0846

www.tsuruga.co.jp