

Instruction Manual

Digital Large Display Meter, Model 4021

I-01950

1. Preface

- Please take care that this instruction manual is certainly delivered to the person in charge of operating this instrument.
- Unpack the product and confirm that the following items are included.
 - (1) 4021 itself
 - (2) Instruction manual
 - (3) CJS (for thermocouple only. It is installed in the terminals)

For safety and proper use of this product, please observe the following caution and also read the instruction manuals to follow before the initial operation.

⚠ CAUTION
<ul style="list-style-type: none"> • The 4021 becomes active as soon as it is connected to a power source. It has no On or Off switch. But warm-up time is necessary at least 15 minutes. • Do not install under the following conditions. <ul style="list-style-type: none"> -Where it is exposed to direct sunlight, dust, corrosive gases, rain, etc. -Where ambient temperature or humidity is high. -Where it is exposed to excessive noise or static electricity. -Where there is constant vibration or shock

2. Standard Specifications

2.1 Model Name

4021- - - - -
 (1) (2) (3) (4) (5)

(1) Measuring Input

[Thermocouple input]

Model	Sensor	Measuring range	Display range	Accuracy <Note>	Overload
4021-02	K	-200 ~ 999 °C	-270 ~ 999 °C	±(0.3% of rdg +1°C)	DC±10 V
4021-04	J	-200 ~ 999 °C	-210 ~ 999 °C	±(0.3% of rdg +1°C)	DC±10 V
4021-05	T	-200 ~ 400 °C	-270 ~ 420 °C	±(0.3% of rdg +1°C)	DC±10 V

< NOTE > Accuracy: Defined at 23°C±5°C, 45 to 75%RH.
 Temperature coefficient: ±300ppm/°C within the 0 to 50°C temperature range.
 Compensation of standard contact: ±1°C within the 0 to 50°C temperature range.
 Calibration: In conjunction with JIS C 1602-1995, by each standard thermoelectric power mV input.

[RTD input]

Model	Sensor	Measuring range	Display range	Accuracy <Note>	Overload
4021-11	Pt100Ω	-200 ~ 850 °C	-200 ~ 870 °C	±(0.4% of rdg +1°C)	DC±10 V
4021-12	Pt100Ω	-99.9 ~ 99.9 °C	-99.9 ~ 99.9 °C	±(0.2% of rdg +0.3°C)	DC±10 V

< NOTE > Accuracy: Defined at 23°C±5°C, 45 to 75%RH.
 Temperature coefficient: ±200ppm/°C within the 0 to 50°C temperature range.
 Calibration: In conjunction with JIS C 1604-1997, by the resistive value of standard resistive elements.

(2) Power Supply

No.	Power
3	AC100 ~ 120V
5	AC200 ~ 240V
9	DC 24V

(3) Mounting

No.	Type	
51	Wall-mount	
52	Hanging-mount	
53	Sticking-mount	
61	Wall-mount	Integral Pt sensor (for RTD input only)
62	Hanging-mount	
63	Sticking-mount	

(4) Color

No	Type
(Null)	Red LED
G	Green LED

(5) Option

No.	Function
(Null)	Peak Hold
A01	Bottom Hold
A02	Change of the burnout direction <NOTE>

< NOTE > : Thermocouple input only.

2.2 General Specifications

Display	: Red or Green LED (character height 56mm) with zero-suppress function.	
Over-range indication	: Flashes at minimum or maximum value of the display range when exceeding.	
Burnout	: Blinking with maximum value of display range.	
Hold Function	: Measured data is held (Not isolated from input).	
Peak Hold	: Maximum value of the measured data is held (Not isolated from input).	
Resolution	: Thermocouple input; 1°C RTD input; 1°C (-11) or 0.1°C(-12)	
Allowable external resistance	: Thermocouple input; 500Ω or less RTD input; 5Ω or less / lead wire (resistance value of 3 wires shall be same)	
Display Cycle	: Approx. 200ms	
Input Type	: Single ended	
A/D Conversion	: Δ - Σ conversion system.	
Noise Rejection	: Normal mode (NMR) - 50dB or more. Common mode (CMR)-110dB or more.	
Noise through power supply line	: 1000V	
Insulation Resistance	Input terminals – Case	: DC500V 100MΩ or more.
	Power terminals – Case	: DC500V 100MΩ or more.
	Power terminals - Input terminals	: DC500V 100MΩ or more.
Withstanding Voltage	Input terminals – Case	: AC1500V each for 1 min.
	Power terminals – Case	: AC1500V each for 1 min.
	Power terminals - Input terminals	: AC1500V each for 1min.
	(in case of DC power supply, AC 500V each for 1 min.)	
Power Supply	: AC100 to 120V 50/60Hz, AC200 to 240V 50/60Hz, DC24V	
Allowable power	: AC85 to 132V 50/60Hz, AC170 to 250V 50/60HZ, DC20 to 30V	
Power Consumption	: Approx. 6VA at AC100V, Approx.10VA at AC200V, Approx.100mA at DC24V	
Operating Temperature	: 0 to 50°C	
Storage Temperature	: -20 to 70°C	
Weight	: Approx. 1.6kg	
Unit	: °C	
Protection	: IP44 (Wall-mount and hanging-mount) IP65 (Sticking-mount with water-proof works)	

2.3 Optional specifications

Bottom Hold function

Display the minimum value of the measured data (Not isolated from input).

In this case, Peak Hold function is disabled.

Change of the burnout direction

It is Available to flash the minimum value when using the thermocouple input.

2.4 Mounting

Wall-mount (model code-51)

NOTE: Cut the case bottom or side to pull out lead wires.

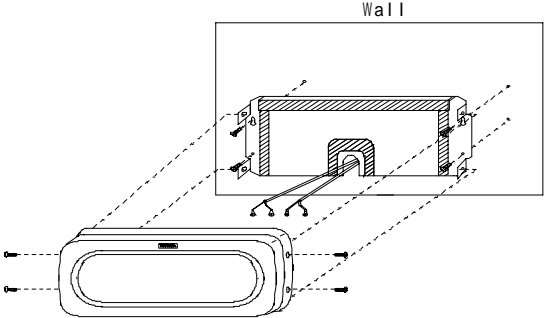

Hanging-mount (model code-52)

NOTE: Fixing points should be locating 10mm away from the wall.

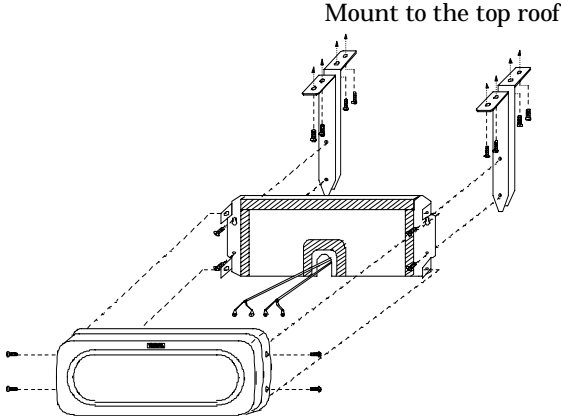

Sticking-mount (model code-53)

NOTE: Use coaching bond or appropriate sealant to keep IP65 protection.

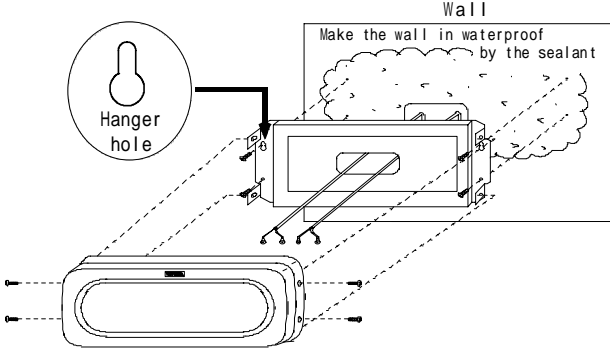

⚠ CAUTION
• Hanger hole of the mounting panel should be upright position as shown in the drawing.

3. Setting of Each Function

• Name of each part

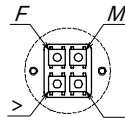
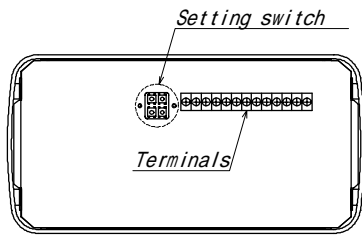
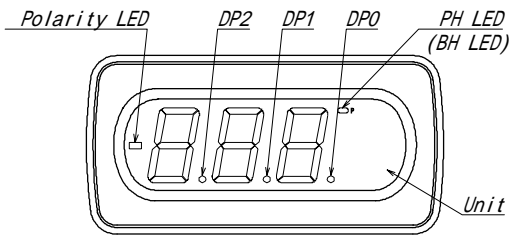

• Display

Lit-up display



Blinking display

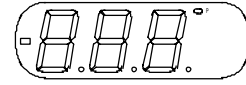

Turned-off display



• Function of each switch

- Functions switch F : Change between the measuring mode and the setting mode.
- Mode switch M : Change parameter item at the setting mode.
- Shift switch > : Move to the next action or shift the value.
- Up switch : Scroll or increase the value or figure

• Setting mode

- Changes to the settings are saved to EEPROM when returning to the measuring mode. Display temporarily turns off the light
- Once flashing the new setting value in the setting mode, it is saved into the memory, and peak value (or bottom value) goes clear.
- If you do not touch any switch for 5 minutes at the setting mode, it automatically returns to the measuring mode without saving changes.

3.1 Setting method

3.1.1 Average operation

Average operates the interval average or the moving average.

Example) Changes the non-average operation to the moving average of 8-data.

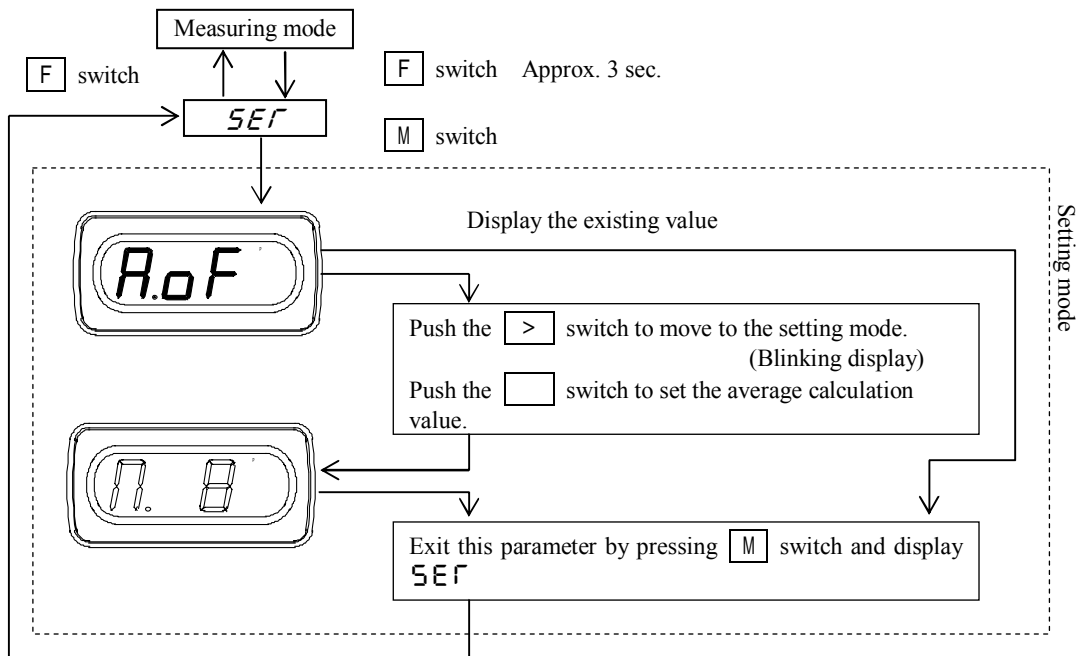

- Since the interval average operates 6-data, display cycle is approx. 1.2s.
- In case of moving average, display cycle is approx. 200ms.

[Default]

Function	Setting value
Average operation	R.on Enable Interval average

[Contents of average operation]

Display	Contents
R.oF	Without average operation
R.on	Interval average
n. 2	Moving average, 2-time
n. 4	Moving average, 4-time
n. 8	Moving average, 8-time
n. 16	Moving average, 16-time
n. 32	Moving average, 32-time

4. Wiring

⚠ CAUTION											
<ul style="list-style-type: none"> • Do not miswiring. Otherwise, the meter is broken. • To avoid an electrical shock, turn the power off when wiring. • Do not wire with moistened hands. Locate away from the wet place. • Do not touch terminals when turning the power on. 											

4.1 Terminal Arrangement

[Thermocouple input]

Terminal	NC	+	-	CJS+	CJS-	COM	HOLD	PH	NC	P2(+)	P1(-)
	1	2	3	4	5	6	7	8	9	10	11
Function	-	Input		CJS		Common	Hold	Peak Hold	-	Power supply	

[RTD input]

Terminal	A	B	B	NC	NC	COM	HOLD	PH	NC	P2(+)	P1(-)
	1	2	3	4	5	6	7	8	9	10	11
Function	Input			-		Common	Hold	Peak Hold	-	Power supply	

Terminal screws: M3

Fastening torque: 0.46~0.62N m

Crimp terminal: As shown on the right.

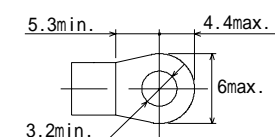

Input terminals

[Thermocouple input]

Pay attention to the polarity when wiring.
CJS is not compatible.

Make sure that the serial number of the CJS and the meter must match.

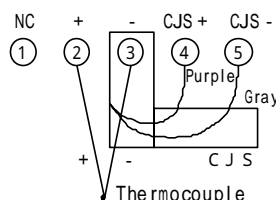

[RTD input]

Connect 3-wire of the RTD.

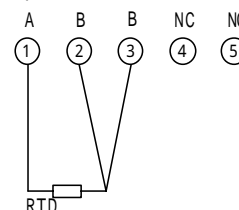

Hold (HOLD)

Display can be held by connecting the Hold terminal and the Common terminal.

Active "L" I_{IL} -1mA, "L"=0 to 0.8V, "H"=3.5 to 5V

Peak Hold (PH)

Maximum value is displayed by connecting the Peak Hold terminal and the Common terminal. "PH" and LED are lit during the peak hold function. This function is released by disconnecting the PH terminal.

Active "L" I_{IL} -1mA, "L"=0 to 0.8V, "H"=3.5 to 5V

Bottom Hold (PH)

If your meter code is -A01, PH terminal is for the bottom hold. Minimum value is displayed by connecting the Peak Hold terminal and the Common terminal. "BH" and LED are lit during the bottom hold function. This function is released by disconnecting the PH terminal.

Active "L" I_{IL} -1mA, "L"=0 to 0.8V, "H"=3.5 to 5V

Common (COM)

"COM" terminal is used for Hold and Peak (or Bottom) Hold terminals.

NOTE: Those terminals, COM, HOLD and PH, are not isolated to the input.

Use a photo-coupler or switch to insulate.

It is essential when using the input floating.

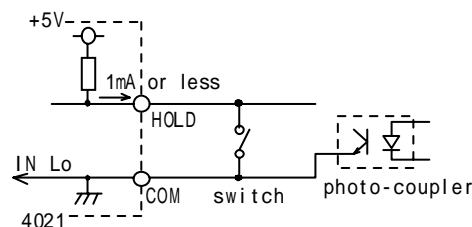

Power Supply (P1(-), P2(+))

The power supply voltage is specified on the terminal plate at delivery from our factory.

- AC power supply(3): Use the meter within the range AC85 to 132V.

- AC power supply(5): Use the meter within the range AC170 to 250V.

- DC power supply(9): Use the meter within the range DC20 to 30V.

Connect +24V positive of DC power to P2 (+), and 0V negative side to P1 (-).

⚠ CAUTION	
Do not use the product with the voltage out of the rated range as it may cause breakage of the products.	

5. Maintenance

Store the meter within the rated storage temperature (from -20 to +70°C). When the front panel or the case is cleaned, use soft cloth dipped with cleaner liquid. Do not use organic solvent like benzene or paint thinner as they may deform or discolor the case.

6. Calibration

In order to maintain long term accuracy, periodical calibration at an interval of about one year is recommended. Make a calibration in the ambient condition of 23°C±5°C, 75%RH or less.

6.1 Calibration of Thermocouple input

Prepare the standard voltage generator, cold contact circuit (ice-bath), and standard thermocouple for calibration.

To enter the calibration mode, turn the power on with pushing **[M]** switch.

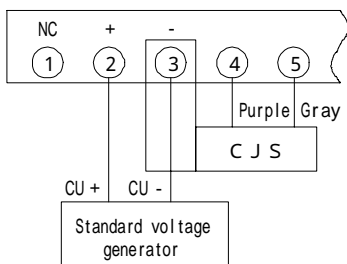
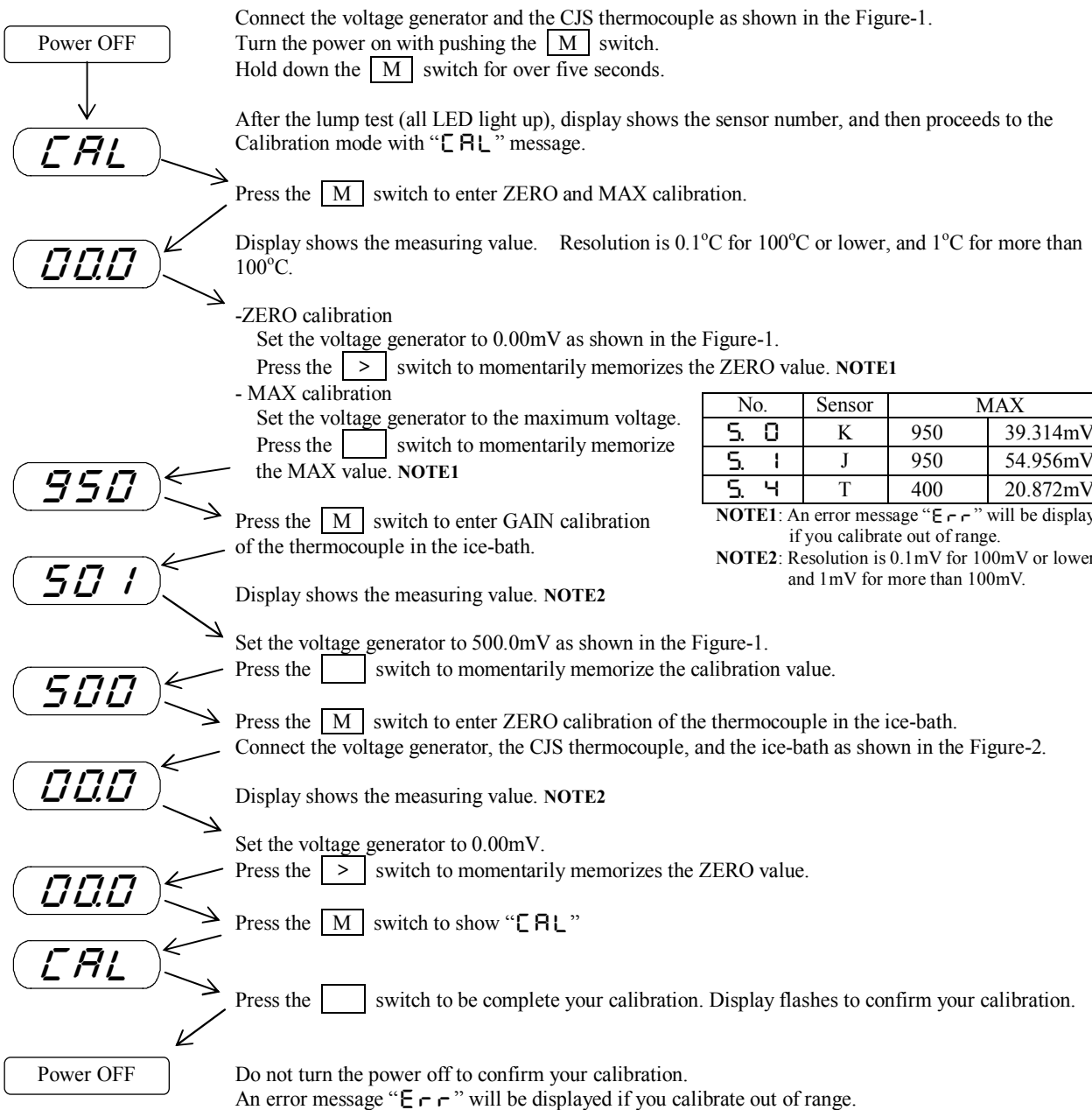

Fig. -1

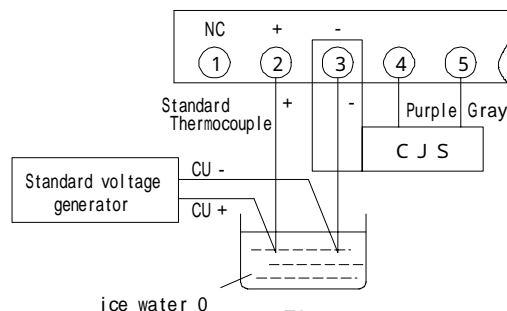

Fig. -2

6.2 Calibration of RTD input

Prepare the standard variable resistor.

To enter the calibration mode, turn the power on with pushing **[M]** switch.

Power OFF

Connect the standard variable resistor as shown in the Figure-3.
Turn the power on with pushing the **[M]** switch.
Hold down the **[M]** switch for over five seconds.

CAL

After the lump test (all LED lit up), display shows the sensor number, and then proceeds to the Calibration mode with "CAL" message.

Press the **[M]** switch to enter ZERO and MAX calibration.

000

Display shows the measuring value. Resolution is 0.1°C for 100°C or lower, and 1°C for more than 100°C.

"S. A" in case of Pt100Ω (-200 to +850°C)

-ZERO calibration

Set the variable resistor to 100.0Ω (0.0°C).

Press the **[>]** switch to momentarily memorizes the ZERO value. **NOTE1**

- MAX calibration

Set the variable resistor to 375.70Ω (800°C).

Press the **[]** switch to momentarily memorize the MAX value. **NOTE1**

No.	Sensor (range)	MAX	
S. A	Pt100 (-200 ~ 850)	800	375.70
S. C	Pt100 (-99.9 ~ 99.9)	95.0	136.61

NOTE1: An error message "Err" will be displayed if you calibrate out of range.

800

Press the **[M]** switch to show "CAL".

CAL

Press the **[]** switch to be complete your calibration. Display flashes to confirm your calibration.

Power OFF

Do not turn the power off to confirm your calibration.
An error message "Err" will be displayed if you calibrate out of range.

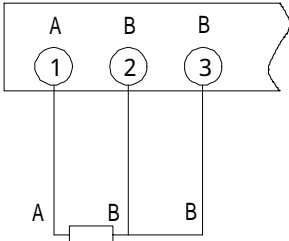

Standard variable resistor

Fig.-3

7. Dimensions

7.1 Basic type

- Wall-mount (-51)

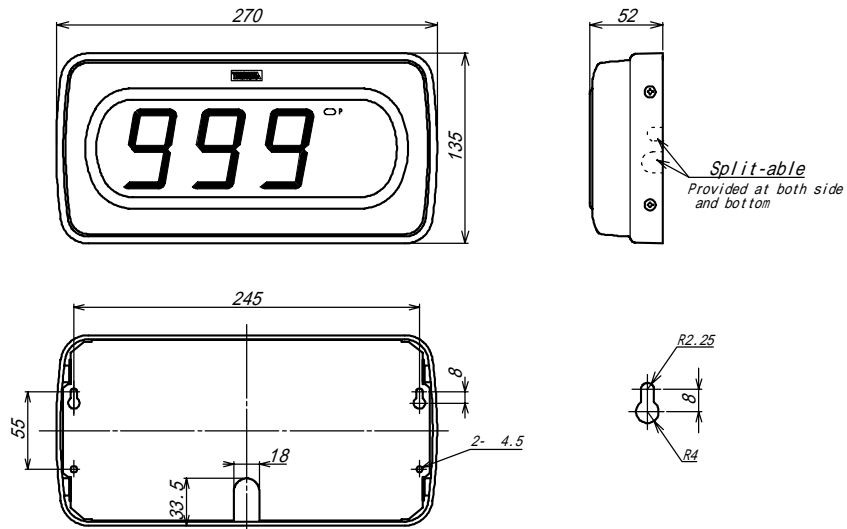

- Hanging-mount (-52)

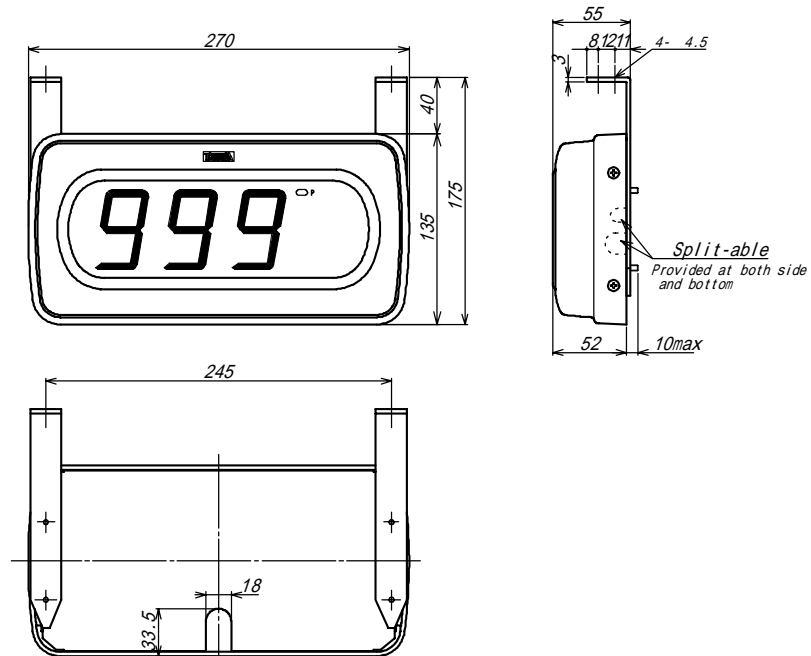

- Sticking-mount (-53)

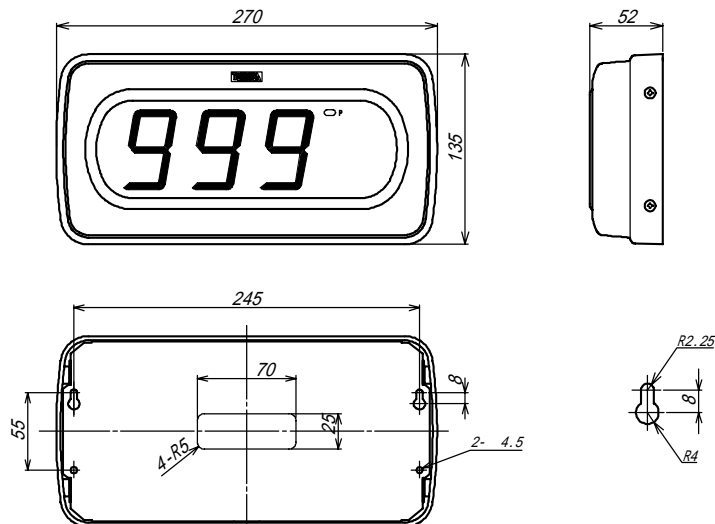

Unit: mm

7.2 Integral Pt sensor

- Wall-mount (-61)

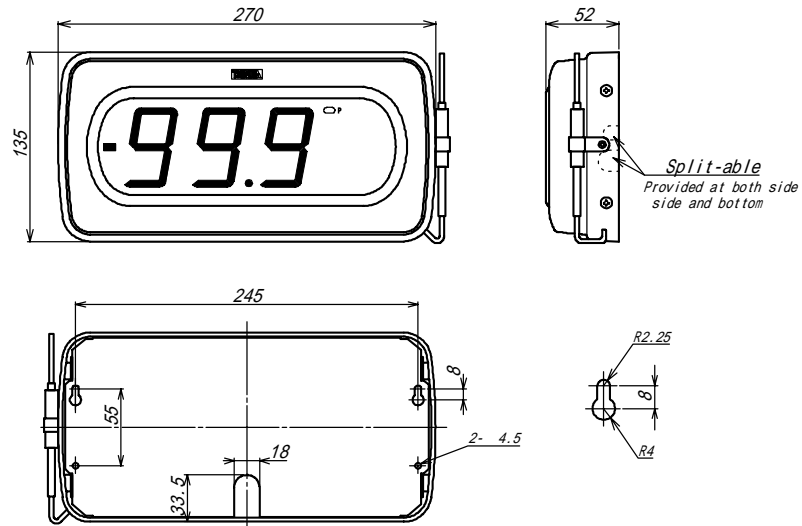

- Hanging-mount (-62)

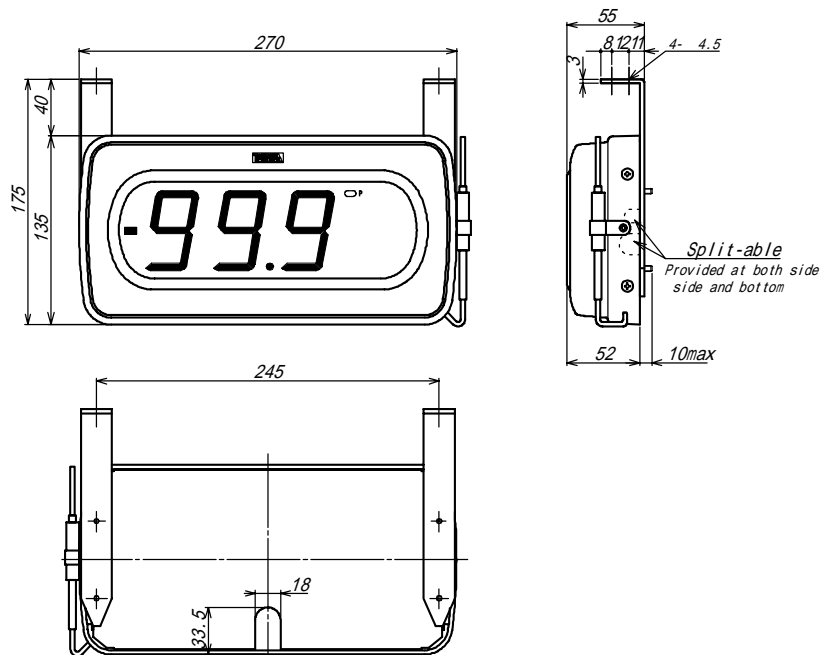

- Sticking-mount (-63)

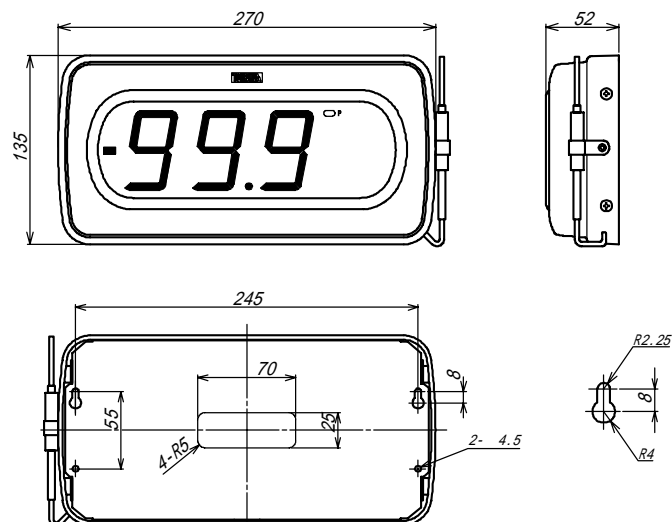

Unit: mm

Contact Information	
Name	: Tsuruga Electric Corporation
Address	: 1-3-23 Minami-Sumiyoshi, Sumiyoshi-ku, Osaka-shi 558-0041 Japan

Instruction Manual

Digital Large Display Meter, Model 4022

I-01951

1. Preface

- Please take care that this instruction manual is certainly delivered to the person in charge of operating this instrument.
- Unpack the product and confirm that the following items are included.
 (1) 4022 itself (2) Instruction manual

For safety and proper use of this product, please observe the following caution and also read the instruction manuals to follow before the initial operation.

⚠ CAUTION

- **The 4022 becomes active as soon as it is connected to a power source. It has no On or Off switch. But warm-up time is necessary at least 15 minutes.**
- **Do not install under the following conditions.**
 - Where it is exposed to direct sunlight, dust, corrosive gases, rain, etc.
 - Where ambient temperature or humidity is high.
 - Where it is exposed to excessive noise or static electricity.
 - Where there is constant vibration or shock.

2. Standard Specifications

2.1 Model Name

4022- - - - -
 (1) (2) (3) (4) (5)

(1) Measuring Input

Model	Measuring range	Input resistance	Accuracy <Note>	Overload
4022-03	± 999 mV	1MΩ	± (0.1% of rdg +1 digit)	DC ±250 V
4022-04	± 9.99 V	1MΩ	± (0.1% of rdg +1 digit)	DC ±250 V
4022-09	DC 1 ~ 5 V	1MΩ	± (0.1% of rdg +2 digit)	DC ±250 V
4022-19	DC 4 ~ 20 mA	12.5Ω	± (0.1% of rdg +2 digit)	DC ±150 mA

< NOTE > Accuracy: Defined at 23°C±5°C, 45 to 75%RH.
 Temperature coefficient: ± 100ppm / °C for the 44022-03, ± 150ppm / °C for the 44022-04, -09, and -19
 Temperature range: 0 to 50°C

(2) Power Supply

No.	Power
3	AC100 ~ 120V
5	AC200 ~ 240V
9	DC 24V

(3) Mounting

No.	Type
51	Wall-mount
52	Hanging-mount
53	Sticking-mount

(4) Color

No	Type
(Null)	Red LED
G	Green LED

(5) Option

No.	Function
(Null)	Peak Hold
A01	Bottom Hold

2.2 General Specifications

Display	: 0 to 999, Red or Green LED (character height 56mm) with zero-suppress function.	
Scaling function	: Full scale display -999 to +999, programmable. Offset display -999 to +999, programmable.	
Hold function:	: Measured data is held (Not isolated from input).	
Peak hold:	: Maximum value of the measured data is held (Not isolated from input).	
Decimal point	: Programmable by the terminal plate (Not isolated from input).	
Over-range indication	: It blinks at 130% display. When exceeded 999, blinking with 000.	
Resolution	: 1/1000	
Display cycle	: Approx. 67ms.	
Zero set function	: Reset the input signal to default.	
Offset fixing function	: Fix a display reading of input less than offset value to the offset value.	
Average function	: Average operates the interval average or the moving average.	
Input type	: Single ended.	
A/D conversion	: Δ - Σ conversion system.	
Noise rejection	Normal mode (NMR)	50dB or more.
	Common mode (CMR)	110dB or more.
Noise through power supply line:	1000V	
Insulation resistance	Input terminals – Case	: DC500V 100M Ω or more.
	Power terminals – Case	: DC500V 100M Ω or more.
	Power terminals – Input terminals	: DC500V 100M Ω or more.
Withstanding voltage	Input terminals – Case	: AC1500V each for 1 min.
	Power terminals – Case	: AC1500V each for 1 min.
	Power terminals – Input terminals	: AC1500V each for 1 min.
	(in case of DC power supply, AC 500V each for 1 min.)	
Power supply	: AC100 to 120V 50/60Hz, AC200 to 240V 50/60Hz, DC24V	
Allowable power	: AC85 to 132V 50/60Hz, AC170 to 250V 50/60HZ, DC20 to 30V	
Power consumption	: Approx. 6VA at AC100V, Approx.10VA at AC200V, Approx.100mA at DC24V	
Operating temperature	: 0 to 50°C	
Storage temperature	: -20 to 70°C	
Weight	: Approx. 1.6kg	
Unit	: Specified character	
Protection	: IP44 (Wall-mount and hanging-mount) IP65 (Sticking-mount with water-proof works)	

2.3 Optional specifications

Bottom Hold function

Display the minimum value of the measured data (Not isolated from input).
In this case, Peak Hold function is disabled.

2.4 Mounting

Wall-mount (model code-51)

NOTE: Cut the case bottom or side to pull out lead wires.

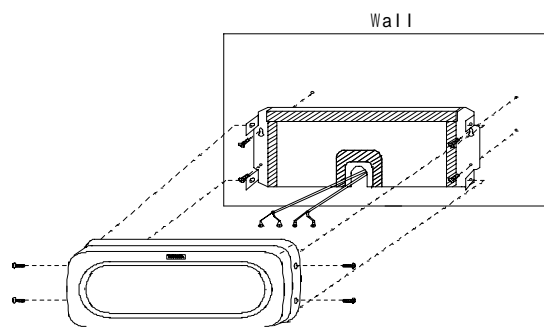

Hanging-mount (model code-52)

NOTE: Fixing points should be locating 10mm away from the wall.

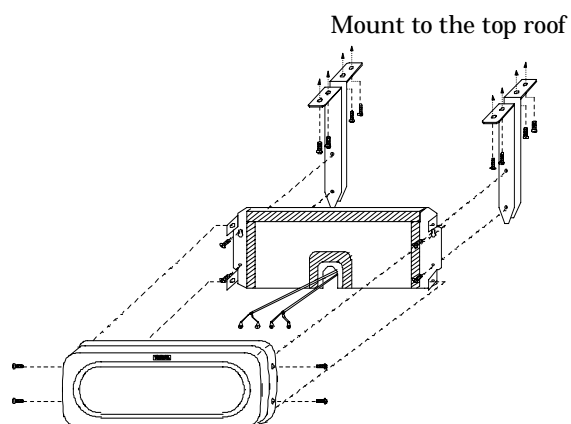

Sticking-mount (model code-53)

NOTE: Use coaching bond or appropriate sealant to keep IP65 protection.

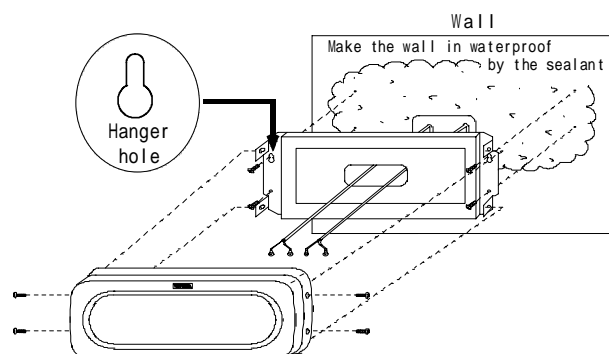

⚠ CAUTION

- Hanger hole of the mounting panel should be upright position as shown in the drawing.

3. Setting of Each Function

• Name of each part

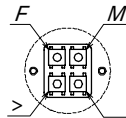
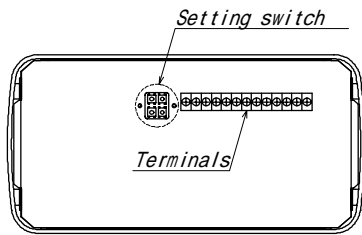
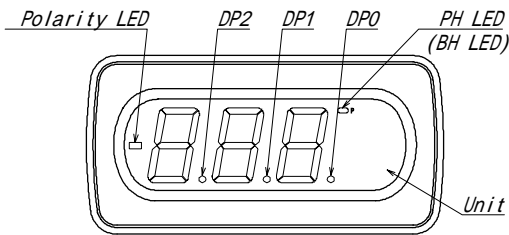

• Display

Lit-up display



Blinking display

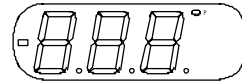

Turned-off display



• Function of each switch

- Functions switch F : Change between the measuring mode and the setting mode.
- Mode switch M : Change parameter item at the setting mode.
- Shift switch > : Move to the next action or shift the value.
- Up switch : Scroll or increase the value or figure.

• Programming configuration

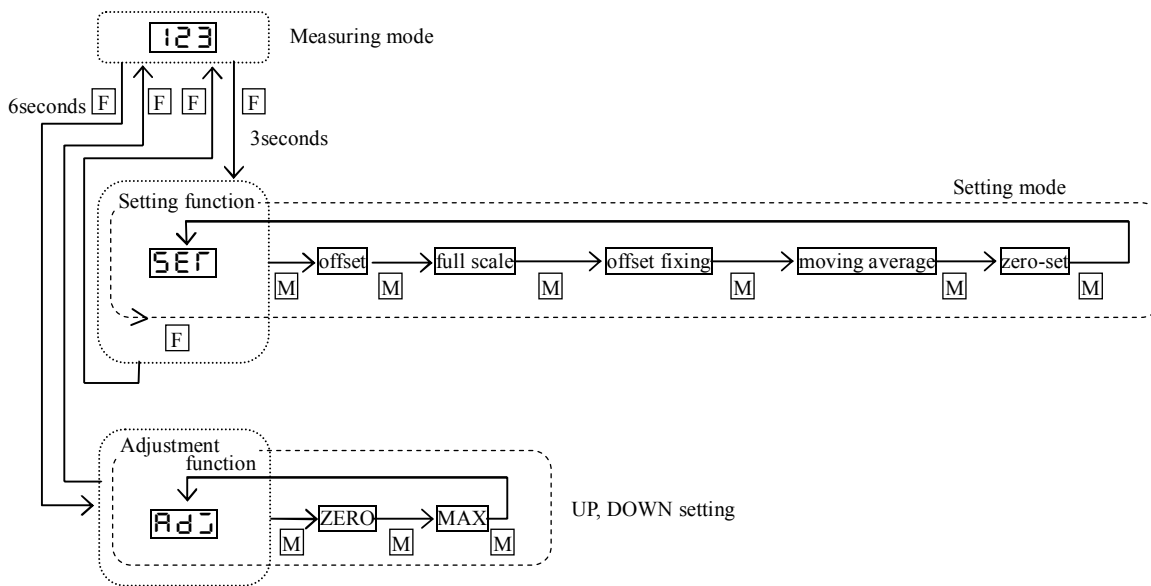

- Push the > switch to move to the setting mode.
- Changes to the settings are saved to EEPROM when returning to the measuring mode and adjustment mode. Display temporarily turns off the light.
- In case of moving average, display cycle is fixed to approx. 67ms.
- Once flashing the new setting value in the setting mode, it is saved into the memory, and peak value (or bottom value) goes clear.
- If you do not touch any switch for 5 minutes at the setting mode, it automatically returns to the measuring mode without saving changes.

3.1 Setting method

3.1.1 Display scaling - Offset setting

Offset display can be set to an arbitrary value.

Example: With the rated input 1 to 5V, the display at the input 1V is adjusted from 0 to 100.

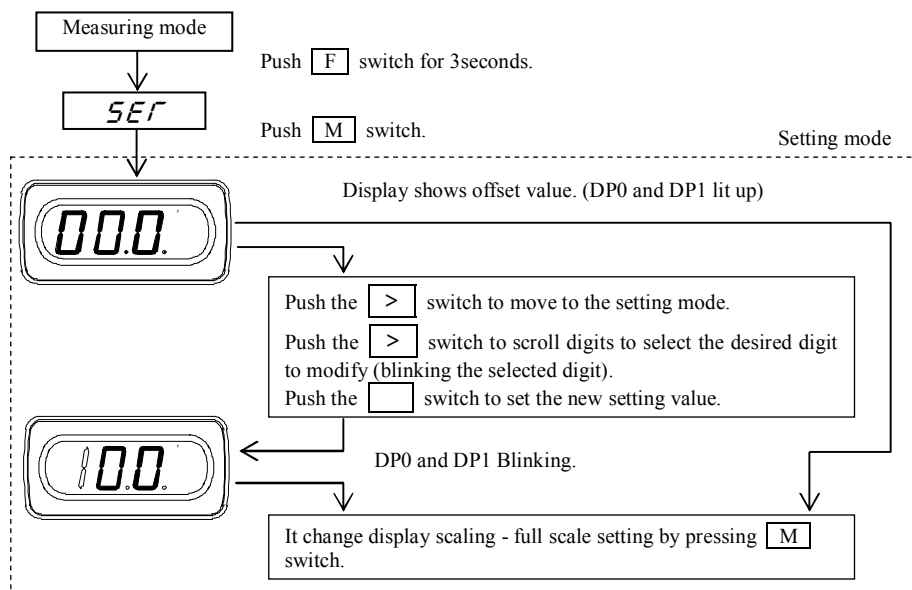

- Offset display means the display at 0mV input for the voltage measuring range, at 1V input for the 1-5VDC range, and at 4mA input for 4-20mA range.

[] switch:
 0 1 2 ... 9 0 1
 In case of 10²-digit:
 0 1 2 ... 9 -9 -8
 ... -1 -0 0 1

3.1.2 Display scaling - Full scale setting

Full scale display can be set to an arbitrary value.

Example: With the rated input 1 to 5V, the display at the input 5V is adjusted from 999 to 599.

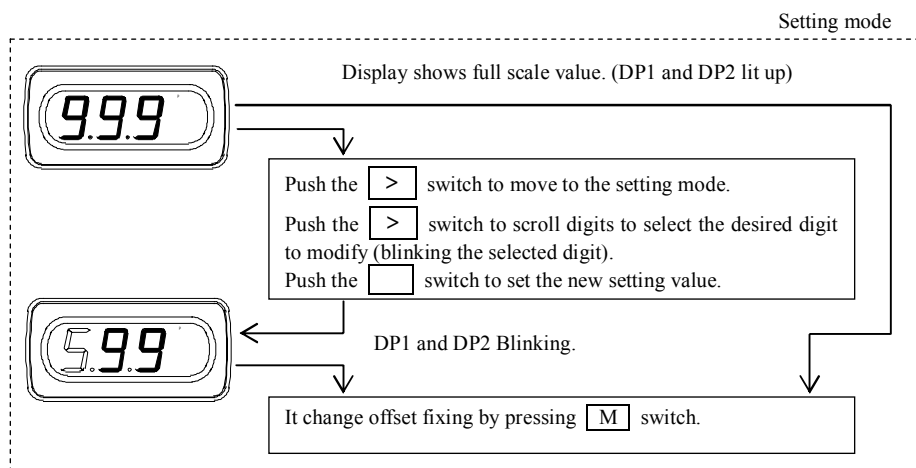

- Full scale display means the display at maximum value input.

[] switch:
 0 1 2 ... 9 0 1
 In case of 10²-digit:
 0 1 2 ... 9 -9 -8
 ... -1 -0 0 1

3.1.3 Offset fixing

Display can be fixed to the offset value when the input value is lower than the offset value.

Example: Change the offset fixing function from disable to enable.

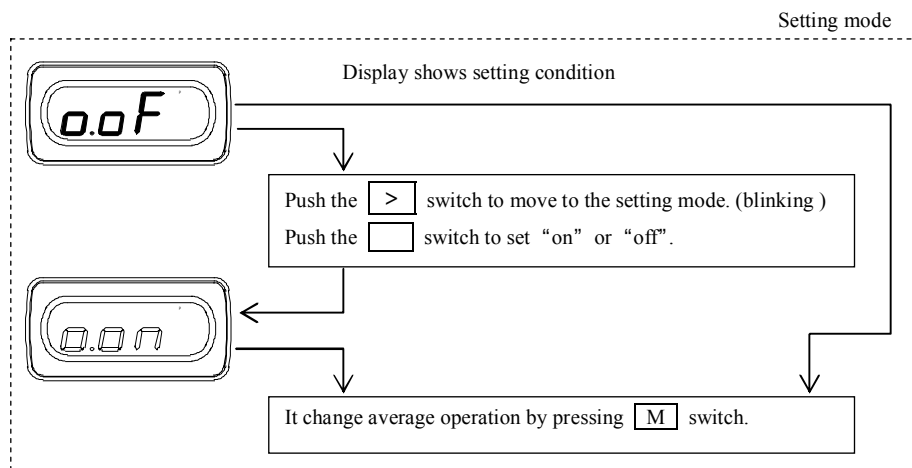

- If your meter chooses the 4-20mA range and sets the display scaling to 100-500, display shows 100 even though the input signal is less than 4mA.

0.0n : Enable the offset fixing.
 0.0F : Disable the offset fixing.

3.1.4 Average operation

Average operates the interval average or the moving average.

Example: Changes the non-average operation to the moving average of 8-data.

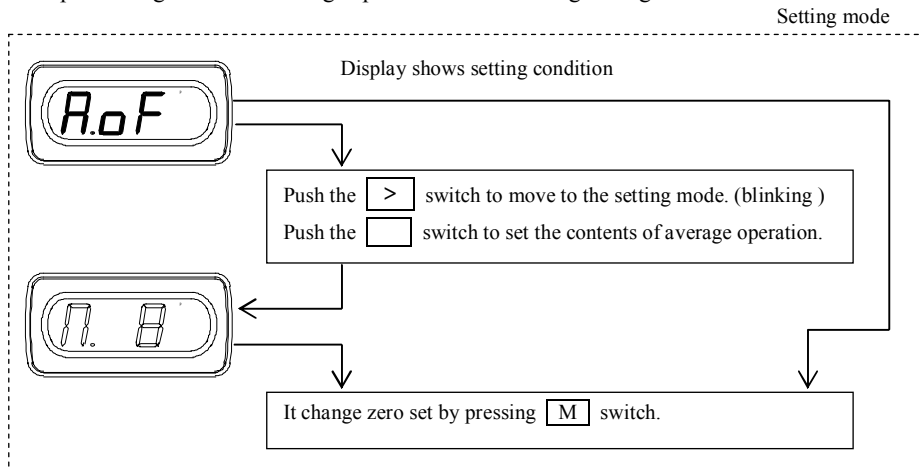

- Since the interval average operates 6-data, display cycle is approx. 400ms.
- In case of moving average, display cycle is approx. 67ms.

[Contents of average operation]

Display	Contents
R.oF	Without average operation
R.on	Interval average
n. 2	Moving average, 2-time
n. 4	Moving average, 4-time
n. 8	Moving average, 8-time
n. 16	Moving average, 16-time
n. 32	Moving average, 32-time

3.1.5 Zero set

Reset the input signal electrically to zero.

Example: Change the zero set function from disable to enable.

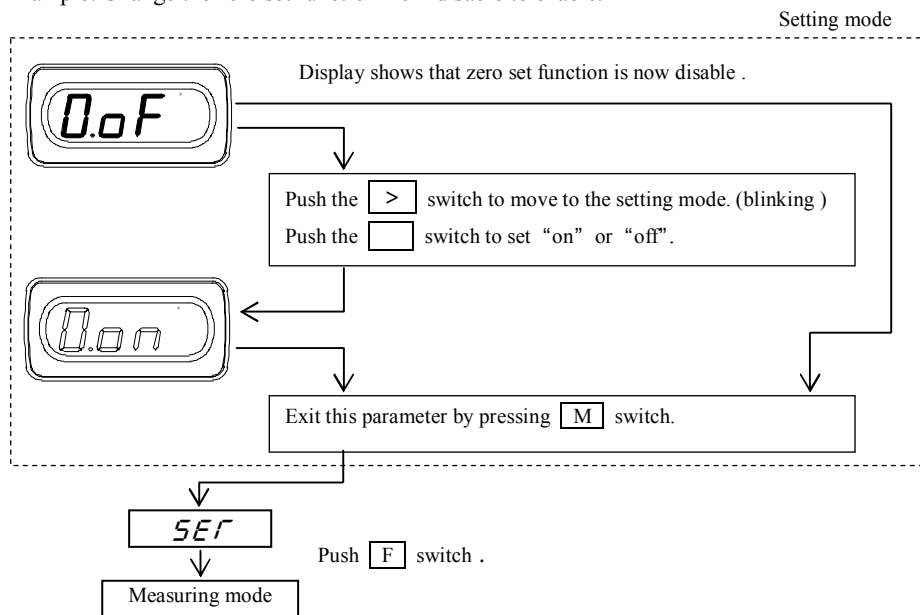

- If you enable the zero set and cause short circuit between the zero set terminal and the COM terminal, display shows the offset value (as same as the setting value at chapter 3.1.1)
 Example:
 If you execute the zero set at 100 when scaling 0-500, display would show -100 to 0 to +400.

0.on : Enable the zero set.
 0.oF : Disable the zero set.

[Default]

Function	Setting value
Offset	000 0
Full scale	999 999
Offset fixing	o.oF Disable
Average operation	R.on Enable interval average
Zero set	0.oF Disable

3.2 Adjustment function

3.2.1 Zero adjustment

Fine calibration of the offset display is available to meet the real input value.
 Example: your meter is 1-5V input, and when inputting 1V, displayed value is 5, not 0.

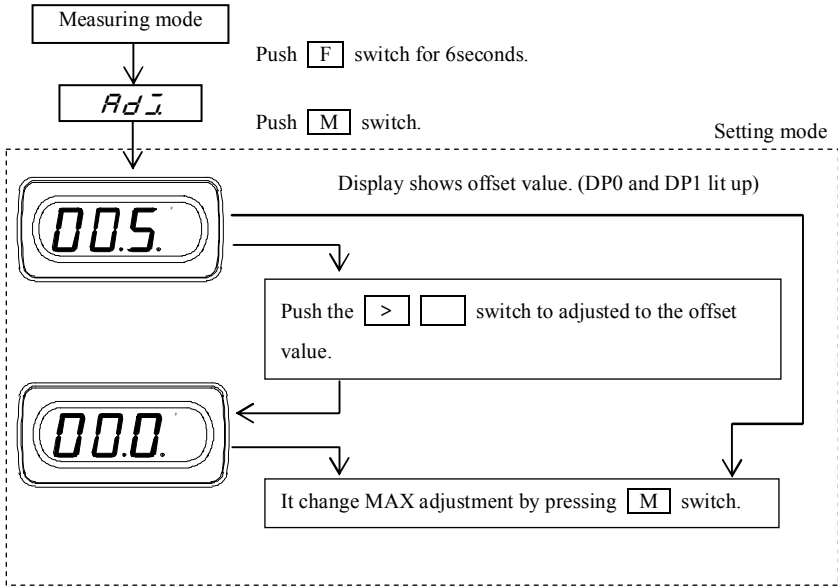

Displayed straight line translates.

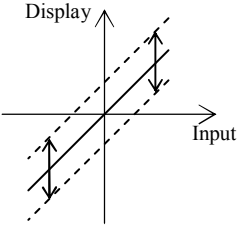

- > switch to scroll the setting value to decrement.
- switch to scroll the setting value to increments.

It may take a while if the scaling width is narrow. Keep the switches pushing for some time.

3.2.2 MAX adjustment

Fine calibration of the maximum display is available to meet the real input value.
 Supply the input as close as the rated maximum value.

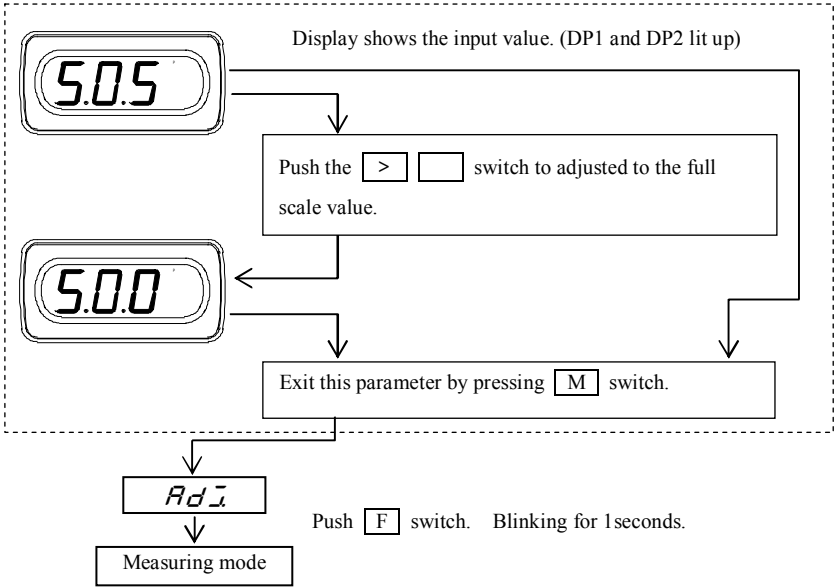

Displayed straight line lists.

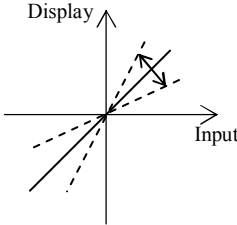

- > switch to scroll the setting value to decrement.
- switch to scroll the setting value to increments.

It may take a while if the scaling width is narrow. Keep the switches pushing for some time.

4. Wiring

⚠ CAUTION	
<ul style="list-style-type: none"> ● Do not miswiring. Otherwise, the meter is broken. ● To avoid an electrical shock, turn the power off when wiring. ● Do not wire with moistened hands. Locate away from the wet place. ● Do not touch terminals when turning the power on. 	

4.1 Terminal Arrangement

Terminal	INHi	NC	INLo	DP1	DP2	COM	HOLD	PH	ZS	P2(+)	P1(-)
	1	2	3	4	5	6	7	8	9	10	11
Function	Input	-	Input	10 ¹ digit	10 ² digit	Common	Hold	Peak hold	Zero set	Power supply	
				Decimal point							

Terminal screws: M3
 Fastening torque: 0.46~0.62N·m
 Crimp terminal: As shown on the right.

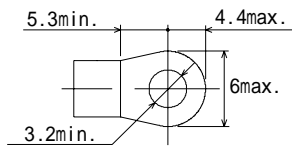

Input terminals (INHi, INLo)

Pay attention to the polarity when wiring. Connect input of higher electric potential to Hi. Input and power line shall lay separately. Otherwise, display may be unstable.

Hold (HOLD)

Display can be held by connecting the Hold terminal and the Common terminal.

Active "L" I_L -1mA, "L"=0 to 0.8V, "H"=3.5 to 5V

Decimal point (DP1, DP2)

Decimal point is programmable.

Connect and short-circuit the desired decimal point terminal, DP1 or DP2, and the common terminal.

Active "L", I_L -1mA, "L"=0 to 0.8V, "H"=3.5 to 5V

If you duplicate both DP1 and DP2, decimal point does not light up.

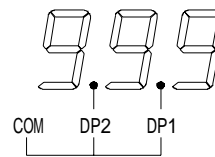

Peak Hold (PH)

Maximum value is displayed by connecting the PH terminal and the Common terminal. "PH" LED are lit during the peak hold function. This function is released by disconnecting the PH terminal.

Active "L" I_L -1mA, "L"=0 to 0.8V, "H"=3.5 to 5V

Bottom Hold (PH)

If your meter code is -A01, PH terminal is for the bottom hold. Minimum value is displayed by connecting the PH terminal and the Common terminal. "PH" and LED are lit during the bottom hold function. This function is released by disconnecting the PH terminal.

Active "L" I_L -1mA, "L"=0 to 0.8V, "H"=3.5 to 5V

Zero set (ZS)

Zero set enables by choosing "on" at the rear switch. Zero set value is memorized into EEPROM for approx. 10 years.

Active "L" I_L -1mA, "L"=0 to 0.8V, "H"=3.5 to 5V

- Method:

1. Shift the rear switch of the zero set to on side.
2. Input the zero set value, and cause short circuit between the zero set terminal and the COM terminal. Display shows 0 (when you set the offset value to 0).
3. If you disconnect the zero set terminal and the COM terminal, zero set value is memorized and zero set function starts.
 Display value = Input value - Zero set value.

- Release

1. Shift the rear switch of the zero set to off side. But zero set value is still memorized.

Common (COM)

“COM” terminal is used for Hold and Peak (or Bottom) Hold, Zero set, and Decimal point terminals.

NOTE: Those terminals, COM, DP1, DP2, HOLD, ZS, PH, are not isolated to the input.

Use a photo-coupler or switch to insulate.

It is essential when using the input floating.

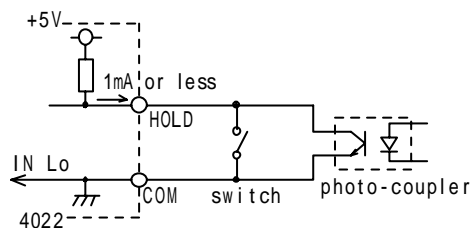
**Power Supply (P1(-), P2(+))**

The power supply voltage is specified on the terminal plate at delivery from our factory.

- AC power supply(3): Use the meter within the range AC85 to 132V.

- AC power supply(5): Use the meter within the range AC170 to 250V.

- DC power supply(9): Use the meter within the range DC20 to 30V.

Connect +24V positive of DC power to P2 (+), and 0V negative side to P1 (-).

⚠ CAUTION

Do not use the product with the voltage out of the rated range as it may cause breakage of the products.

5. Maintenance

Store the meter within the rated storage temperature (from -20 to +70°C). When the front panel or the case is cleaned, use soft cloth dipped with cleaner liquid. Do not use organic solvent like benzene or paint thinner as they may deform or discolor the case.

6. Calibration

In order to maintain long term accuracy, periodical calibration at an interval of about one year is recommended.

Refer to the chapter 3.2 for calibration.

Make a calibration in the ambient condition of 23°C±5°C, 75%RH or less.

7. Dimensions

- Wall-mount (-51)

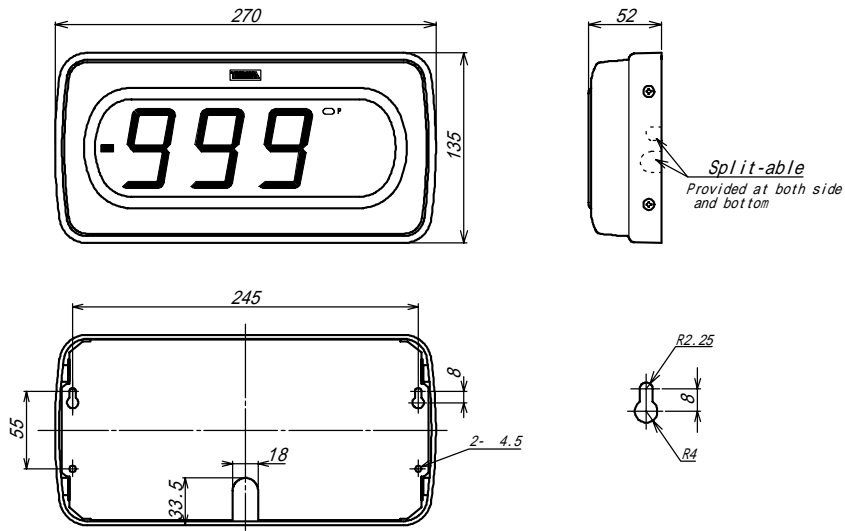

- Hanging-mount (-52)

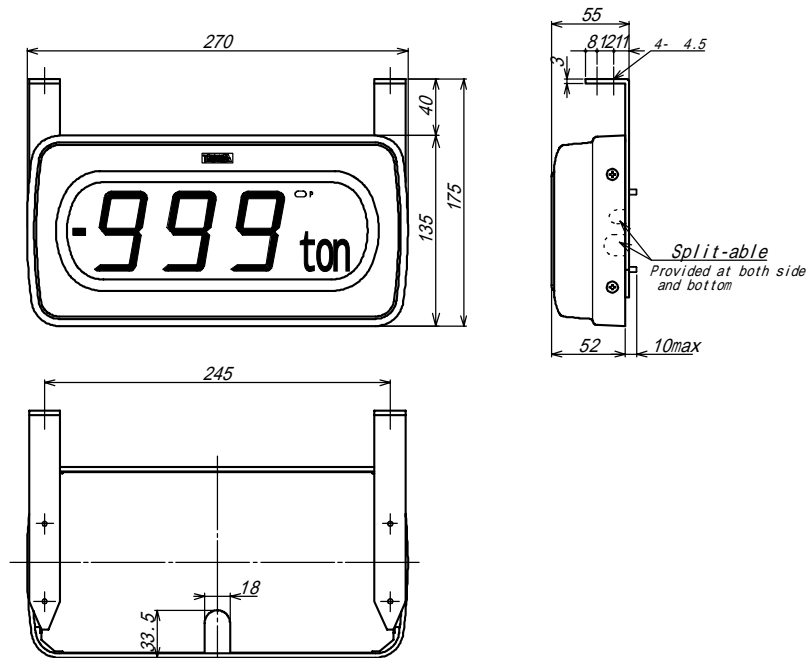

- Sticking-mount (-53)

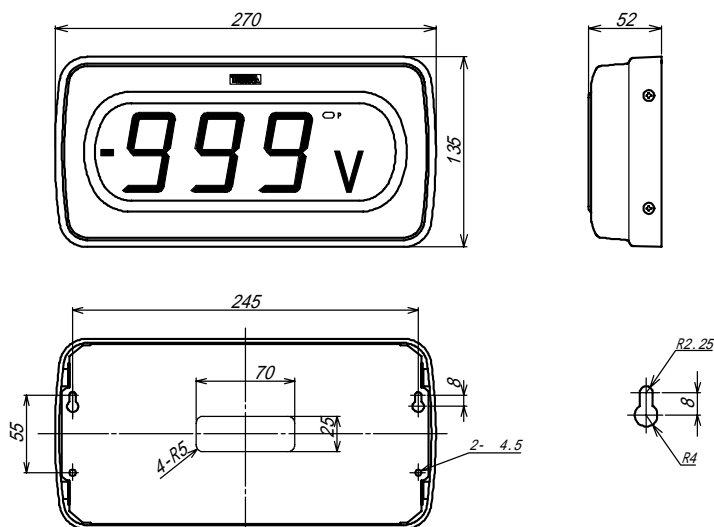

Unit: mm

Contact Information

Name : Tsuruga Electric Corporation
 Address : 1-3-23 Minami-Sumiyoshi, Sumiyoshi-ku, Osaka-shi
 558-0041 Japan