

Quick Manual

Digital Panel Meter with Totalizer Function, Model 419A

I-01912

Thank you for purchasing our digital panel meter 419A series.
 This meter indicates instantaneous and integrating flow rate by receiving the analog signal from the flow meter.
 Before use, read this manual carefully and thoroughly, and keep this manual available for routine reference.
 Refer to our Instruction manual for details

1. Preface

1.1 Inspection

- Remove the meter from box. Inspect the packaging and contents for damage. Report damages, if any, to the carrier. If any part is missing or the meter malfunctions, please contact your supplier or the factory for assistance with your information of model name and serial number.
- Please check contents of the package you received as outlined below.
 - (1) 419A itself
 - (2) This manual

1.2 Keeping and maintenance

- Install the meter temperature in a cool and dry place, away from direct sunlight

⚠ CAUTION
<ul style="list-style-type: none"> - Preserve the 419A in the range of -20 to +70 °C . - Wipe the front panel or the case by the soft cloth with a mild neutral cleanser if it is dirty. Do not use solvent such as thinner nor benzene to avoid deform nor discolor.

1.3 Precautions

⚠ CAUTION
<p>Preserve followings for your safety.</p> <ul style="list-style-type: none"> - There is no power on-off switch on the model 419A. It immediately starts to operate after turning the power. The rated data is, however, defines with more than 15 minutes warming-up times. - When the product is installed in the cabinet, perform the appropriate heat radiation to keep less than 50°C in it. - Do not install under the following conditions. <ul style="list-style-type: none"> - Where it is exposed to direct sunlight, dust, corrosive gases, rain, etc. - Where ambient temperature or humidity is high. - Where it is exposed to excessive noise or static electricity. - Where there is constant vibration or shock.

2. Model Numbering

419A	-		-		-		-	
------	---	--	---	--	---	--	---	--

Measuring range	DC0 ~ 99.99 mV	02			
	DC0 ~ 999.9 mV	03			
	DC0 ~ 5 V	04			
	DC0 ~ 9.999 V	05			
	DC1 ~ 5 V	09			
	DC0 ~ 999.9μA	23			
	DC4 ~ 20 mA	29			
	DC4 ~ 20 mA	29R			
	Power supply	AC100 ~ 240V			
DC12V		8			
DC24V		9			
Power for sensor	N/A	Null			
	12V±5%	3			
	24V±5%	5			
Data output	No output				Null
	Analog	DC0 ~ 1V			03
		DC0 ~ 5V			04
		DC0 ~ 10V			05
		DC1 ~ 5V			09
		DC4 ~ 20mA			29
RS-485		E1			

3. Specifications

3.1 Instantaneous value measurement

Instantaneous value display:

- 0~9999 : Red LED, Character 8mm High, with zero-suppress function.
- Decimal point : Programmable form the front key
- Over-range indication : Blinking with 110% scaling data. When exceeded 9999, blinking with 0000.
- Turned off : Changeover to be put on or off.

Note) Alarm, pause, and latch will be operated when the display is blank.

- Display cycle : Selectable from the front key. 100ms, 400ms, 1s, 2s, 5s
- Moving averaging : Selectable from the front key. 1, 2, 3, 4, 8, 16-time
- Accuracy : $\pm 0.2\%$ of SPAN at $23^{\circ}\text{C} \pm 5^{\circ}\text{C}$ 45~75%RH
- Temperature coefficient : $\pm 200\text{ppm}/^{\circ}\text{C}$
- Input type : Single ended, floating
- Field adjustment : The function which is able to arbitrarily change the measuring value without laborious calibration.

Instantaneous average VS Moving average

Instantaneous display cycle	Numbers of Moving average	Setting
100ms	N/A	1/2/3/4/8/16-time
400ms	4-time per 100ms	Not available
1s	10-time per 100ms	
2s	20-time per 100ms	
5s	50 time per 100ms	

3.2 Totalized value measurement

Totalized value display : 0~99999 : Green LED, Character 8mm High, with zero-suppress function.

5 or 10 significant digit: Programmable form the front key
There is display switch of 5 high rank digits at 10-digit counter.

- Decimal point : Programmable form the front key
- Over-range indication : In case of 5-digit, count from 0 with blinking when exceeded 5-digit.
In case of 10-digit, count from 0 with blinking when exceeded 10-digit.
The presence selection function of blinking is provided.
- Turned off : Changeover to be put on or off.

Note) Alarm, reset, pause, and latch totalized P.O will be operated when the display is blank.

- Totalizing constant : Values integrated in 1 hour at 100% input, programmable from the front key.
- Initial totalized value : from 0 to 99999, programmable from the front key.
- Display cycle : approx. 0.1s
- Accuracy : $\pm(0.2\%+1\text{digit})$ of rated value.
Rated value: theoretical value when input 100% continuously.

Totalization synchronizing pulse output(P.O) :

- Output the pulse signal which is simulated with the totalized count.
- Output capacity: open collector output (NPN), DC30V 200mA
- Pulse factor: programmable from 1/1, 1/10, and 1/100 of integration by changing segmented frequency ratio.
- Pulse width: Selectable in accordance with output frequency.

- 100ms: at 0 to 5Hz
- 50ms: at 0 to 10 Hz
- 10ms: at 0 to 30Hz

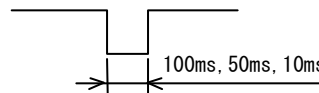

Reset : RESET switch inside the front panel or RESET terminals on the rear terminal blocks allow to reset the totalized count (to 0) or to the initial totalizing value. It also clears the incomplete batch of pulses of P.O. output.

- Input to the terminal: non-voltage contact or open collector (NPN) DC5V 10mA
- Active "L", "L"=0~1V, "H"=3.5~5V, 10ms min. Pulse width.
- Keep pushing the reset key more than 1 sec to rest. Available the reset key to disable.

3.3 Common Specifications

- Cut off : 0 to 10%: Programmable from the front key.
- Latch / Pause input : Latch : Hold of display and data output of instantaneous and totalized value. (except of Simultaneous pulse output). Count of totalizing is continued.
- : Pause : Hold of display and data output of instantaneous and totalized value.
Count of totalizing is temporarily stopped.
- Non-voltage contact or open collector (NPN) DC5V 10mA
- Active "L", "L"=0~1V, "H"=3.5~5V, 10ms min. Pulse width.
- Option: hold both analog output and RS-485 output.

Power to the sensor :

code	voltage	output current	Ripple
null	-	-	-
3	12V \pm 5%	60mA	5% or less
5	24V \pm 5%	30mA	5% or less

- Backup : An EEPROM retains the data of accumulated total flow when the power is interrupted.
Keep 10 years.
- Alarm output : Relay contact: AC/DC 150V 80mA
- Noise filter : 50dB at normal mode
110dB at common mode
- Power source line penetrating noise : 1000V
- Withstanding Voltage : Power supply terminals – Case : AC1500V each for 1 min.
Input terminals – Case : AC1500V each for 1 min.
Power supply terminals - Input and Output terminals : AC1500V each for 1min.
Input terminals – Analog output/RS-485 output terminals : AC500V each for 1 min.
- Insulation Resistance : DC500V 100MΩ or more.
- Power Supply : AC 100 to 240V (50/60HZ), DC12V±10%, DC24V±10%
- Allowable power : AC 90 to 250V (50/60Hz), DC10.8 to 13.2V, DC21.6 to 26.4V
- Power Consumption : Approx. 7.5VA at AC100V, 10VA at AC200V, 400mA at DC12V, 250mA at DC24V.
- Operating Temperature : 0 to 50°C
- Storage Temperature : -20 to 70°C
- Weight : Approx. 160g
- Mounting Method : Panel mount from the rear with the special bracket.

3.4 Total Reset function

3.4.1 When outputting H and HH alarm

- In case of the total reset function is enable, resets the total to the initial integrated value.
- In case of the total reset function is disable, resets the total to zero.
- When the total exceeds the over flow value, total reset automatically either enable or disable, count from zero.

3.4.2 When outputting batch output

(a) In case of the automatic total reset is disable

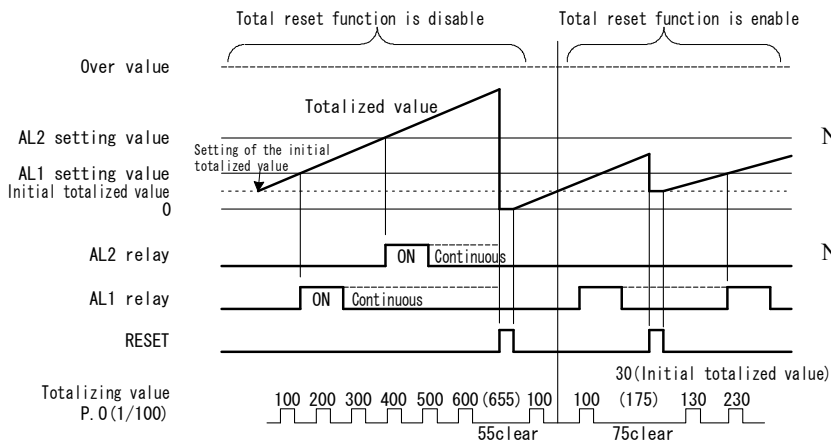

NOTES 1: In case of the total reset function is disable, resets the total to zero and frequency dividing of P.O. output goes clear.

NOTES 2: In case of the total reset function is enable, resets the total to initial value and frequency dividing of P.O. output goes clear.

(b) In case of the automatic total reset is enable

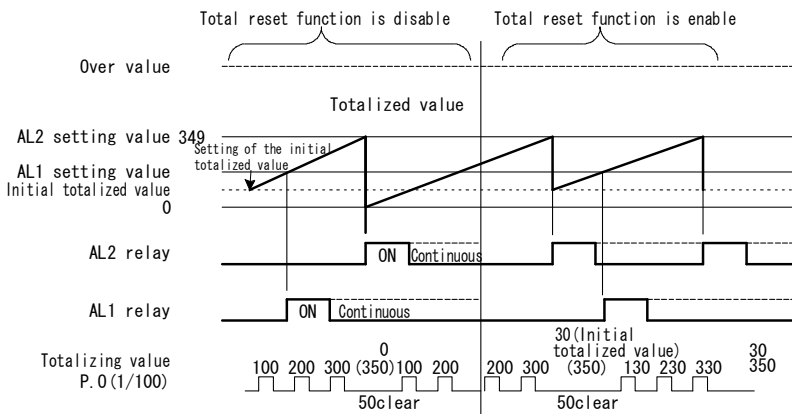

NOTES 3: In case of the total reset function is disable, automatically resets the total to zero and frequency dividing of P.O. output goes clear.

NOTES 4: In case of the total reset function is enable, automatically resets the total to initial value and frequency dividing of P.O. output goes clear.

NOTES 5: Setting range of the AL2 setting value: initial value < AL2 (display Err2 if you set to the out of range)

3.5 Alarm output

Alarm will outputs by switching back and forth either instantaneous value alarm (AL1 lower, AL2 upper) or integrating value alarm (H and HH alarm or two-level batch) at AL1 and AL2.

3.5.1 Instantaneous value alarm

Outputs upper and lower alarm (on the front panel monitor).

Setting range is from 0 to 9999. Outputs to simulate the instantaneous display frequency.

► Condition of comparison

Instantaneous value > Upper setting value, AL2OUT ON (lit up the AL2 on the front panel monitor)

Instantaneous value < Lower setting value, AL1OUT ON (lit up the AL1 on the front panel monitor)

Judgment \ Output	AL1 OUT-COM	AL2 OUT-COM
high alarm	OFF	ON
Low alarm	ON	OFF

NOTE: Reset is enable to the totalized value, Instantaneous value alarm does not return.

3.5.2 Totalized value alarm output

Totalized value alarm outputs by switching back and forth either H and HH alarm or two-level batch.

H and HH alarm will compare to the display, and batch output will compare to total value (NOTE 1).

Delay of the relay output: Max. 20ms to the display at HH alarm. Max.120ms at batch output.

NOTE 1: Alarm may output due to display frequency delay against quicker totalized count which is faster than 0.1s.

(a) H and HH alarm output (on the front panel monitor).

Setting range is from 0 to 99999.

► Condition of comparison

Integrating value > H alarm setting value, AL1OUT ON (lit up the AL1 on the front panel monitor)

Integrating value > HH alarm setting value, AL2OUT ON (lit up the AL2 on the front panel monitor)

Judgment \ Output	AL1 OUT-COM	AL2 OUT-COM
high alarm	ON	OFF
HH alarm	OFF	ON

(b) Batch output (on the front panel monitor).

If the total value and the setting value become same at the two-level batch of AL1OUT and AL2OUT, the relay outputs ON pulse.

Pulse width is programmable from 100ms, 200ms, 500ms, 1s, and continuous, which is common to AL1 (T1) and AL2 (T2).

AL2OUT is an output with the automatic reset on-off function for the totalized value.

NOTE : Continuous output switches off by inputting the reset.

NOTE : Reset the meter if switch the H and HH alarm output to the batch output. If the total value is smaller than al1 or AL2, reset is not necessary.

【 In case of the automatic reset function is disable 】

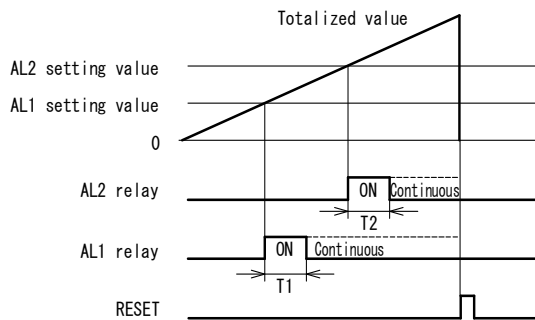

【 In case of the automatic reset function is enable 】

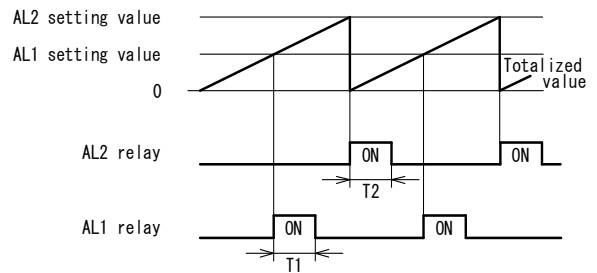

4. Mounting

Detach the special bracket from the case, and insert the case from the panel front.

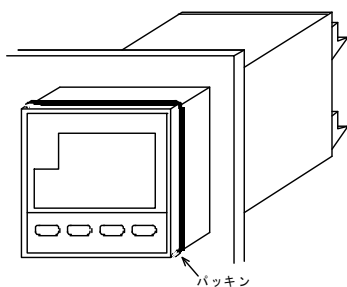

Panel thickness:

Recommended panel thickness is 0.6 to 5mm in case of the non-water-proof condition. For light panel, such as aluminum, should be 1.5mm or more to avoid deform.

Recommended panel thickness is 1.5 to 5mm in case of the gasket usage.

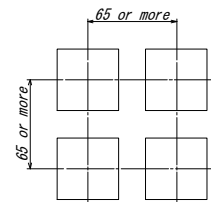
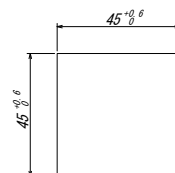

Panel cut dimension: $45^{+0.6/0} \times 45^{+0.6/0}$ mm

Fix the case to the panel by using the mounting bracket.

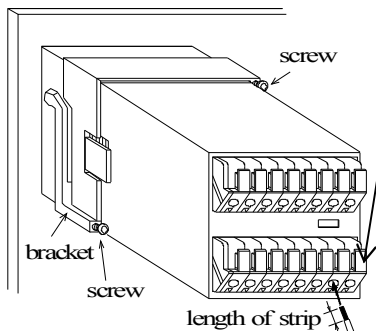

Push this portion (lever) to insert the wire for connection.
You can directly insert hard single-wire without pushing

Connecting wire:

- solid wire: within 0.4 - 1.2mm² (AWG26 - 16)
 - twisted wire: within 0.3 - 0.75mm² (AWG22 - 20)
- Diameter of solid conductor is more than 0.18mm²

5. Name of parts

5.1 Front panel

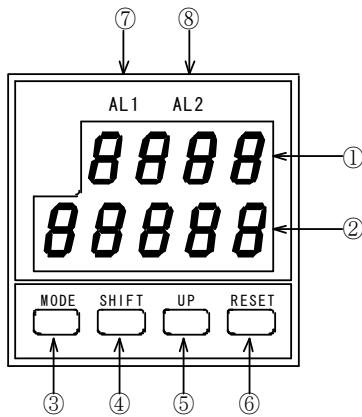

- ① Instantaneous display: <when measuring> Display instantaneous value.
<when setting> Display item of each function.
- ② Totalizing display: <when measuring> Display totalized value.
<when setting> Display setting value or function group.
- ③ **MODE** key: <when setting> Switch each item.
- ④ **SHIFT** key: <when setting> Move the digit
- ⑤ **UP** key: <when setting> Change or switch the setting value.
<when measuring> In case of 10-digit integrating display, switch to upper 5-digit display by keep the **UP** key pushing.
- ⑥ **RESET** key: <when measuring> Reset totalized value by pushing more than 1 sec. Available to lock **RESET** key operation.
- ⑨ AL1: Alarm output display for AL1
- ⑩ AL2: Alarm output display for AL2

⚠ Push each key with the round-tipped object, such as the bottom of the ball point pen

5.2 Rear panel

5.2.1 Terminal layout

for AC power supply

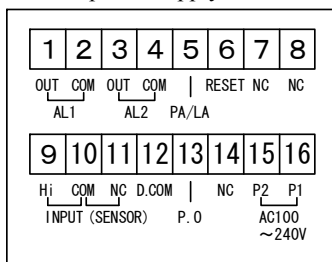

for DC12V power supply

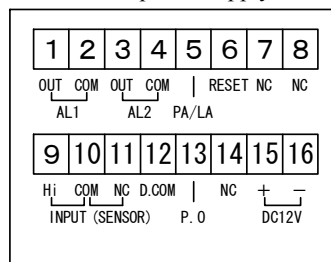

for DC24V power supply

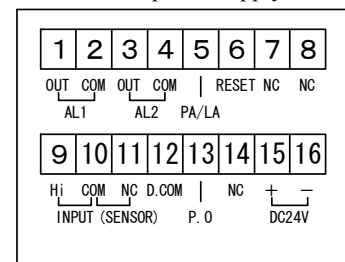

⚠ WARNING

- Do not miswiring to avoid the meter broken
- The power shall be turned off during wiring to avoid personal injury.
- Do not wire at the highly humid location. Do not wire with wet hands. Otherwise, you may get an electrical shock.
- Do not touch to the power terminals after turning on the power.
- Make sure the polarity of DC power supply to avoid the meter broken.

5.2.2 Explanation of upper terminals

From terminal 1 to 4: Preset output (AL1OUT, AL2OUT, AL1COM, AL2COM)

Output relay capacity: AC/DC 150V 80mA, Normally Open. Resistance read (photo MOS relay).

Terminal 5: Pause / Latch input (PA / LA)

Pause or latch operation will start when short-circuiting this terminal to the D.COM terminal.

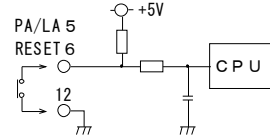

Terminal 6: RESET

Reset totalized value when short-circuiting this terminal to the D.COM terminal.

NOTE: Preset output does not return, but continuous integrated batch output return.

5.2.3 Explanation of lower terminals

Terminal 9: Input (Hi)

Make sure the polarity of DC power supply.

Connect the higher potential side to the terminal 9, and lower to the terminal 10.

The input line and the power line shall be independent.

Do not lay down the input line and the power line in parallel to avoid unstable display.

Terminal 10: Common (Com)

Common terminal for the input and the sensor.

Terminal 11: SENSOR or NC

Make sure the polarity of DC power supply. Common terminal 0V shall connect to the terminal 10.

NOTE: This terminal may be not connected when the sensor power is not supplied. Do not use for junction purpose.

Terminal 12: Data Common (D.COM)

Common terminal for P.O, RESET, and PA/LA.

Terminal 13: Pulse output (P.O)

Outputs the totalization-synchronized pulse in open collector (NPN).

Terminal 14: NC

This terminal may be not connected. Do not use for junction purpose.

Terminal 15 and 16: Power supply (P2, P1) at the AC power supply

Use for AC 90 to 264V.

Terminal 15 and 16: Power supply (+, -) at the DC power supply

Use for DC 12 or 24V power supply.

12V: Use for 10.8 to 13.2V DC.

24V: Use for 21.6 to 26.4V DC.

+ and - should match to the marking on the terminals.

6. Wiring Example

(1) Example for the sensor power supply (+V and 0V)

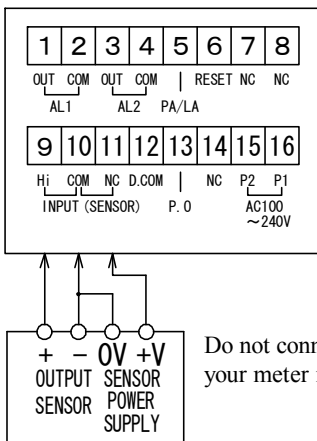

Do not connect to the terminal 11 if your meter is not supplied the sensor power.

(2) Example for 2-wire transmitter

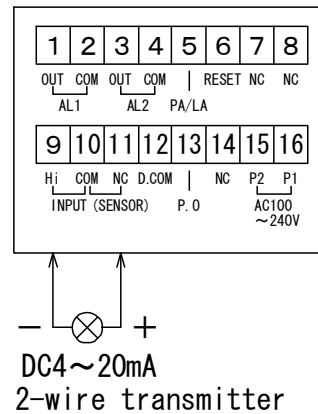

DC4~20mA
2-wire transmitter

7. Programming Example

7.1 Example:

m³ display for totalized value rate and m³/h for instantaneous value rate

Condition: Output of the flow meter: DC 4-20mA

Flow in proportional to 4-20mA: 0 to 100 m³/h

Min. display of the integrating flow rate: 1m³/h. Min. display of the integrating flow rate: 1m³

Setting Menu	Function	Setting value	
F 1- 1(00 100)	Totalizing constant	100	In 1 hour at 100% input
F 1- 2(00000)	Initial totalized value	0	
F 1- 3(000 10)	Rate offset (instantaneous)	0	
F 1- 4(0 100)	Rate full scale (instantaneous)	100	
F 2- 1(0.0000) *NOTE	Rate display cycle	100ms	
F 2- 1(0.0000) *NOTE	Total decimal point	None	No decimal point
F 2- 1(0.0000) *NOTE	Instantaneous decimal point	None	No decimal point
F 2- 2(CUR 1)	Cutoff	1%	

NOTE: Reverse character means corresponding digit in the setting menu.

8. Default setting

Function	Default setting	Setting menu	Display example
Totalizing constant	20	F 1- 1	00020
Initial totalizing value	0	F 1- 2	00000
Rate offset (instantaneous)	0	F 1- 3	0000
Rate full scale (instantaneous)	9999	F 1- 4	9999
Rate display frequency	100ms	F 2- 1	0.0000
Moving average	1-time		
Turned off	Display (total/inst.)		
DP(Total)	None		
DP(Inst)	None		
Cutoff	0%	F 2- 2	CUR0
P.O (Pulse width)	100ms	F 2- 3	0.00L
P.O (Divided frequency ratio)	1/1		
Reset key, Enable/Disable	Enable		
Switch of the Latch/Pause	Latch		
Total Overflow	Blinking	F 2- 4	0.00
Reset function	OFF		
Integrated 5-digit/ 10-digit	5-digit		
Alarm mode (none/inst./total/batch)	None	F 3- 1	AL0
Decimal setting for 10-digit, Automatic reset	No display		
Alarm output pulse width	No display		
AL1	No display	F 3- 2	-----
AL2	No display	F 3- 3	-----
Analog output mode (total/inst.) *NOTE	Instantaneous	F 4- 1	0
RS-485, meter numbering *NOTE	0	F 4- 1	00
Analog output constant *NOTE	No display	F 4- 2	-----

NOTE: Setting menu, F 4- 1 and F 4- 2, does not display at the standard (no output), but display at the optional.

9. Setup and Programming

<How to enter the Setup mode>



Enter the Setup or the Calibration mode

- Press the **MODE** key for 2 sec or more. Func. and CAL. flashes and then lit up.

NOTE: If you will release the **MODE** key when flashing Func. and CAL., return to the Measuring mode.



Choose the Setup mode

- Each time you press the **SHIFT** key, Func. and CAL. alternately flashes. Choose the Func.



Enter the setup mode

- Press the **UP** key to scroll through the menu from Func. 1 to Func.3 (Func.4 if you use optional type). Example drawing shows Func. 1

- Refer to totalizing constant for details.

F1-1 Totalizing constant

- Values totalizing constant in 1 hour at 100% input, programmable from the front key.
- Setting range is from 20 to 99999.

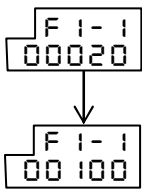

Enter the setup mode

- Choose the Setup mode as mentioned in the opening sentence of **How to enter the Setup mode**.
- Choose F1-1 by pressing the **MODE** key.

Change totalizing constant

- Press the **SHIFT** key to move to the right. The digit you choose will be blinking.
- Update the data by pressing the **UP** key. Example: change from 20 to 100.

Move to the next menu

- The display moves to the next menu, F1-2, by pressing the **MODE** key.

Return to the Measuring mode

- Press the **MODE** key to choose **Func. 1**.
- Press the **UP** key until the **Func.3** or **Func.4** (option) is displayed. Then, press the **UP** key once again to return the Measuring mode.

F1-2 Initial totalized value

- Setting range is from 0 to 99999 (in case of 10-digit total, the range should be within the last 5-digit).

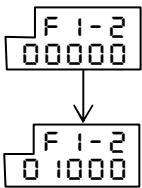

Enter the setup mode

- Choose the Setup mode as mentioned in the opening sentence of **How to enter the Setup mode**.
- Choose F1-2 by pressing the **MODE** key.

Change Initial totalized value

- Press the **SHIFT** key to move to the right. The digit you choose will be blinking.
- Update the data by pressing the **UP** key. Example: change from 0 to 1000.

Move to the next menu

- The display moves to the next menu, F1-3, by pressing the **MODE** key.

Return to the Measuring mode

- Press the **MODE** key to choose **Func. 1**.
- Press the **UP** key until the **Func.3** or **Func.4** (option) is displayed. Then, press the **UP** key once again to return the Measuring mode.

F1-3 Instantaneous offset

- Rate offset is an instantaneous display value at 0% input.

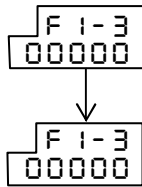

Enter the setup mode

- Choose the Setup mode as mentioned in the opening sentence of **How to enter the Setup mode**.
- Choose F1-3 by pressing the **MODE** key.

Change instantaneous offset

- Press the **SHIFT** key to move to the right. The digit you choose will be blinking.
- Update the data by pressing the **UP** key.

Move to the next menu

- The display moves to the next menu, F1-4, by pressing the **MODE** key.

Return to the Measuring mode

- Press the **MODE** key to choose **Func. 1**.
- Press the **UP** key until the **Func.3** or **Func.4** (option) is displayed. Then, press the **UP** key once again to return the Measuring mode.

F1-4 Instantaneous full scale

- Rate full scale is an instantaneous display value at 100% input.
- Setting range is from 0 to 9999.

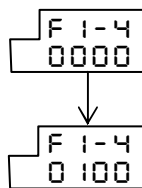

Enter the setup mode

- Choose the Setup mode as mentioned in the opening sentence of **How to enter the Setup mode**.
- Choose F1-4 by pressing the **MODE** key.

Change instantaneous full scale

- Press the **SHIFT** key to move to the right. The digit you choose will be blinking.
- Update the data by pressing the **UP** key. Example: change from 0 to 100.

Move to the next menu

- Choose **Func. 1** by pressing the **MODE** key.
- Choose **Func.2** by pressing the **UP** key.
- Press the **MODE** key to enter the F2-1 menu.

Return to the Measuring mode

- Press the **MODE** key to choose **Func. 1**.
- Press the **UP** key until the **Func.3** or **Func.4** (option) is displayed. Then, press the **UP** key once again to return the Measuring mode.

F2-1 Instantaneous display frequency, Moving average, Turned off, Decimal Point

- The meter can be set to display with 100ms, 400ms, 1s, 2s, or 5s interval.
- Moving average should be set to 1-, 2-, 3-, 4-, 8-, or 16-time when you choose 100ms.
- Any combination of light-up and light-off is selectable from the table below.
- Decimal point of total and inst may be set with up to three decimal places or with no decimal point at all.

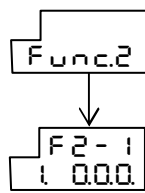

Enter the setup mode

- Choose the Setup mode as mentioned in the opening sentence of **How to enter the Setup mode**.
- Choose **Func.2** by pressing the **UP** key.

Change Instantaneous display cycle, Moving average, Turned off, Decimal Point

- Choose F2-1 by pressing the **MODE** key.
- Press the **SHIFT** key to move to the right. The digit you choose will be blinking.
- Update the data by pressing the **UP** key.

Instantaneous display frequency	0	-	-	-	100ms	-
	1	-	-	-	400ms	Digit of moving average is dead, and the setting of moving average is impossible.
	2	-	-	-	1s	
	3	-	-	-	2s	
	4	-	-	-	5s	
Moving average	0	-	-	-	1-time	
	1	-	-	-	2-time	
	2	-	-	-	3-time	
	3	-	-	-	4-time	
	4	-	-	-	8-time	
	5	-	-	-	16-time	
Turned off (total / inst.)	0	-	-	-	Total: lit-up / Rate: lit-up	-
	1	-	-	-	Total: lit-up / Rate: turned off	
	2	-	-	-	Total: turned off / Rate: lit-up	
	3	-	-	-	Total: turned off / Rate: turned off	
Decimal Point (total)	0	-	-	-	0	In case of 10-digit totalized, the range should be within the last 5-digit. Refer to the menu F2-4.
	1	-	-	-	0.0	
	2	-	-	-	0.00	
	3	-	-	-	0.000	
	4	-	-	-	0.0000	
Decimal Point (Instantaneous)	0	-	-	-	0	-
	1	-	-	-	0.0	
	2	-	-	-	0.00	
	3	-	-	-	0.000	

It is enable to change moving average at the 100ms frequency only.

Move to the next menu

- The display moves to the next menu, F2-2, by pressing the **MODE** key.

Return to the Measuring mode

- Press the **MODE** key to choose **Func.2**
- Press the **UP** key until the **Func.3** or **Func.4** (option) is displayed. Then, press the **UP** key once again to return the Measuring mode.

F2-2 Cutoff

- The low-flow cutoff feature allows the meter to be programmed so that the often-unsteady output from a differential pressure transmitter, at low flow rates, always displays zero on the meter.
- Example:
Input: DC4-20mA Display: 0 to 100m³/h
If you set 1%, below 4.16mA, the meter will display 0m³/h.
- Setting range is from 0 to 10%.

Enter the setup mode

- Choose the Setup mode as mentioned in the opening sentence of **How to enter the Setup mode**.
- Choose **Func.2** by pressing the **UP** key.
- Choose F2-2 by pressing the **MODE** key.

Change Cutoff

- Press the **SHIFT** key to move to the right. The digit you choose will be blinking.
- Update the data by pressing the **UP** key.

Move to the next menu

- The display moves to the next menu, F2-3, by pressing the **MODE** key.

Return to the Measuring mode

- Press the **MODE** key to choose **Func.2**
- Press the **UP** key until the **Func.3** or **Func.4** (option) is displayed. Then, press the **UP** key once again to return the Measuring mode.

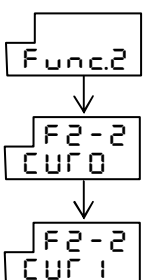

F2-3 P.O (Pulse width), P.O (Divided frequency ratio), Reset key, Enable/Disable, Switch of the Latch/Pause

- o Set P.O (Pulse width), P.O (Divided frequency ratio), Reset key, Enable/Disable, Switch of the Latch/Pause

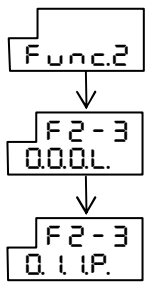

Enter the setup mode

- Choose the Setup mode as mentioned in the opening sentence of **How to enter the Setup mode** .
- Choose **Func.2** by pressing the **UP** key.
- Choose F2-3 by pressing the **MODE** key.

Change P.O (Pulse width), P.O (Divided frequency ratio), Reset key, Enable/Disable, Switch of the Latch/Pause

- Press the **SHIFT** key to move to the right. The digit you choose will blinking.
 - Update the data by pressing the **UP** key.
- Example: 100ms Pulse width, 1/10 Divided frequency ratio, Disable Reset key, Switch of the Pause

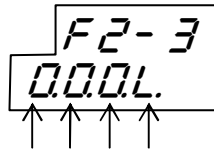

SHIFT : Choose the right digit
UP : Update the setting value

- P.O (Pulse width) NOTE1,2
- P.O (Divided frequency ratio)
- Reset key
- Latch/Pause

0	-	-	-	100ms
1	-	-	-	50ms
2	-	-	-	10ms
0	-	-	-	1/1
1	-	-	-	1/10
2	-	-	-	1/100
0	-	-	-	Reset by pressing the key for 1 sec.
1	-	-	-	Disable
	L	-	-	Latch
	P	-	-	Pause

NOTE 1:

Allowable pulse width can be calculated using the following formula.

$$P.O \text{ (pulse width)} < \text{Output Frequency}$$

$$\text{where Output Frequency} = (1 / (\text{Integration constant} / 3600\text{sec.})) \times \text{Divided frequency ratio}$$

If PO is wider than output frequency, output signal will be continuous, not to be pulse.

NOTE 2:

If you would choose 99999 for integration constant and 1/1 for divided frequency ratio, output frequency may be 27.78Hz.

This is derived as follows: $99999 / 3600\text{sec.} \times 1 = 27.78\text{Hz}$

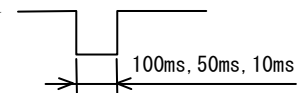

Move to the next menu

- The display moves to the next menu, F2-4, by pressing the **MODE** key.

Return to the Measuring mode

- Press the **MODE** key to choose **Func.2**
- Press the **UP** key until the **Func.3** or **Func.4** (option) is displayed. Then, press the **UP** key once again to return the Measuring mode.

F2-4 Total Overflow, Reset function, Totalized 5-digit/10-digit

- o Totalized display may blinking lit up when overflowing.
- o Set to disable or enable of the reset function
- o Set number of the totalized digit to 5 or 10.

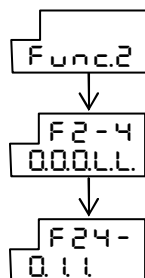

Enter the setup mode

- Choose the Setup mode as mentioned in the opening sentence of **How to enter the Setup mode** .
- Choose **Func.2** by pressing the **UP** key.
- Choose F2-4 by pressing the **MODE** key.

Change Total Overflow, Reset function, Totalized 5-digit/10-digit

- Press the **SHIFT** key to move to the right. The digit you choose will blinking.
- Update the data by pressing the **UP** key.

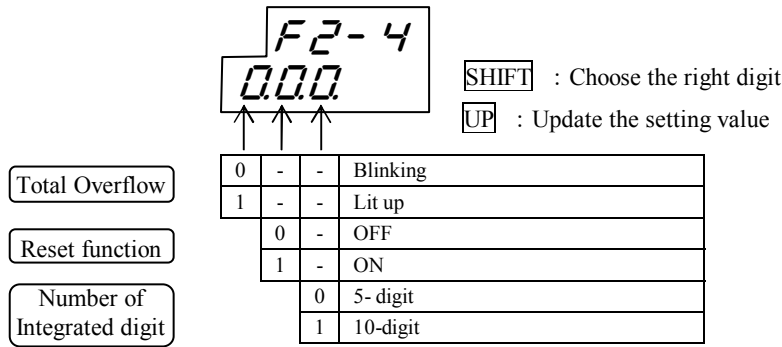

Move to the next menu

- Choose **F_{unc.2}** by pressing the **MODE** key.
- Choose **F_{unc.3}** by pressing the **UP** key.
- Press the **MODE** key to enter the F3-1 menu.

Return to the Measuring mode

- Press the **MODE** key to choose **F_{unc.2}**
- Press the **UP** key until the **F_{unc.3}** or **F_{unc.4}** (option) is displayed. Then, press the UP key once again to return the Measuring mode.

F3-1 Alarm mode (none/inst./total/batch), Decimal setting for 10-digit, Automatic reset, Alarm output pulse width

- o AL1OUT and AL2OUT are set to compare with total or instantaneous.
- o Set to digit for 10-digit total integrating.
- o Choose ON or OFF for automatic reset.
- o Set the width of alarm output pulse.

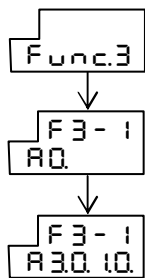

Enter the setup mode

- Choose the Setup mode as mentioned in the opening sentence of **How to enter the Setup mode**.
- Choose **F_{unc.3}** by pressing the **UP** key.
- Choose F3-1 by pressing the **MODE** key.

Change Alarm mode, Decimal setting for 10-digit, Automatic reset, Alarm output pulse width

- Press the **SHIFT** key to move to the right. The digit you choose will be blinking.
 - Update the data by pressing the **UP** key.
- Example: batch for Alarm mode, 10-digit for Decimal setting, Continuous for Pulse width.

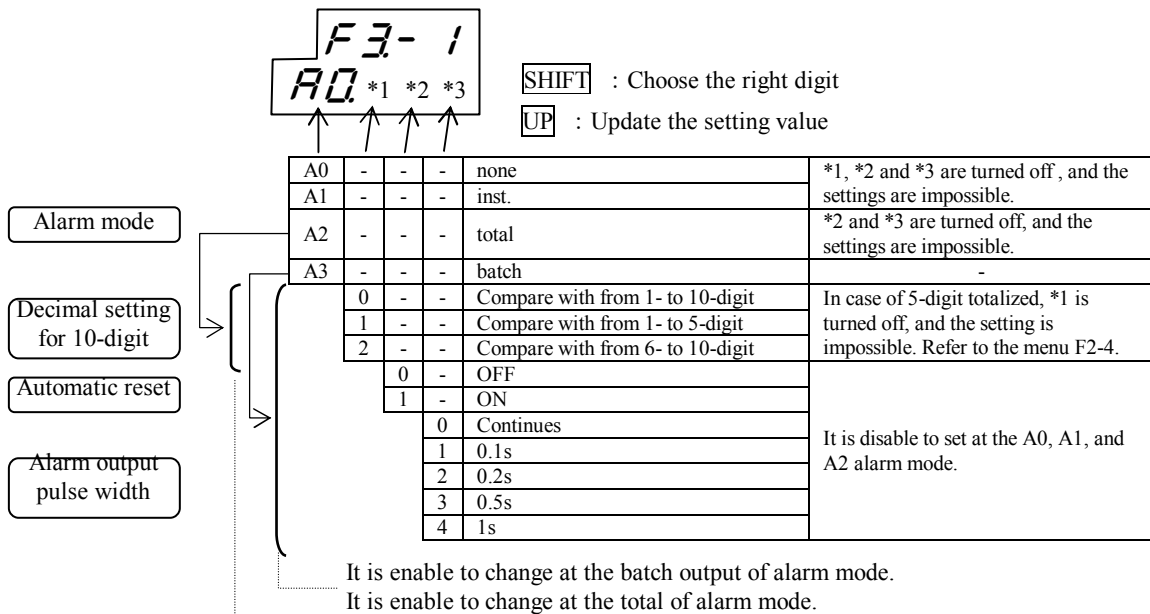

Move to the next menu

- The display moves to the next menu, F3-2, by pressing the **MODE** key.

Return to the Measuring mode

- Press the **MODE** key to choose **F_{unc.3}** or **F_{unc.4}** (option)
- Press the **UP** key to return the Measuring mode.

F3-2 AL1

- Set the output value of AL1.
- Setting range is in accordance with the setting of F3-1.

Setting of F3-1	Comparison method	Setting Range	Compared digit
A0: None alarm	—	—	—
A1: Instantaneous alarm	L	0000 to 9999	Compare with display value of inst
5-digit (inst.)	H	00000 to 99999	Compare with 5-digit
0: 1- to 10-digit	H	00000 to 99999	Compare with *****00000 to *****99999 Example 1
1: 1- to 5-digit	H	00000 to 99999	Compare with 00000 to 99999 Example 2
2: 6- to 10-digit	H	00000 to 99999	Compare with 00000***** to 99999***** Example 3

* means the numerical value from 0 to 9

Examples at 60000 setting value

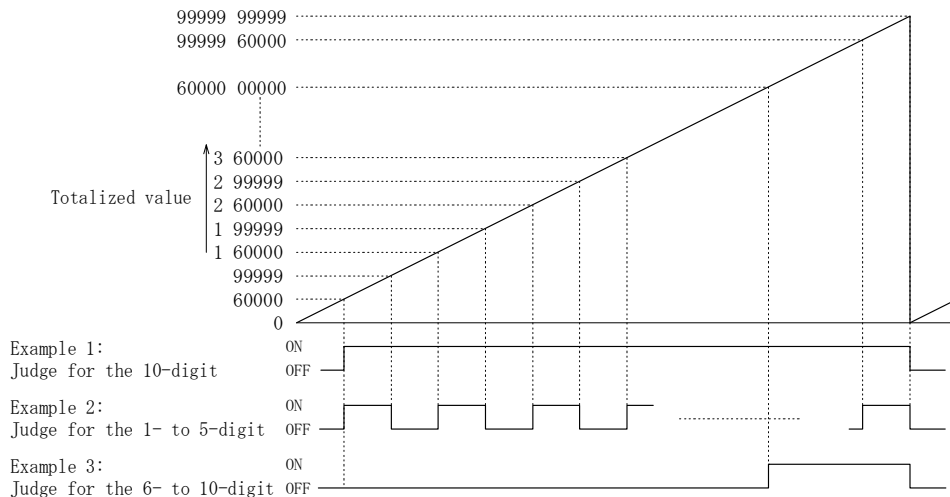

Enter the setup mode

- Choose the Setup mode as mentioned in the opening sentence of **How to enter the Setup mode**.
- Choose **F u n c . 3** by pressing the **[UP]** key.
- Choose F3-2 by pressing the **[MODE]** key.

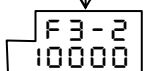
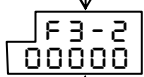

Change AL1

- Press the **[SHIFT]** key to move to the right. The digit you choose will be blinking.
- Update the data by pressing the **[UP]** key.

Move to the next menu

- The display moves to the next menu, F3-3, by pressing the **[MODE]** key.

Return to the Measuring mode

- Press the **[MODE]** key to choose **F u n c . 3** or **F u n c . 4** (option)
- Press the **[UP]** key to return the Measuring mode.

F3-3 AL2

- Set the output value of AL2.
- Setting range is in accordance with the setting of F3-1.

Setting of F3-1	Comparison method	Setting Range	Compared digit
A0: None alarm	—	—	—
A1: Instantaneous alarm	H	0000 to 9999	Compare with display value of rate
5-digit (inst.)	HH	00000 to 99999	Compare with 5-digit
0: 1- to 10-digit	HH	00000 to 99999	Compare with *****00000 to *****99999 Refer to Example 1 at F3-2.
1: 1- to 5-digit	HH	00000 to 99999	Compare with 00000 to 99999 Refer to Example 2 at F3-2.
2: 6- to 10-digit	HH	00000 to 99999	Compare with 00000***** to 99999***** Refer to Example 3 at F3-2.

* means the numerical value from 0 to 9

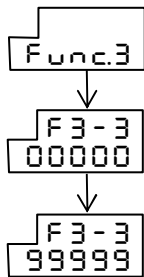

Enter the setup mode

- Choose the Setup mode as mentioned in the opening sentence of **How to enter the Setup mode**.
- Choose **Func.3** by pressing the **UP** key.
- Choose F3-3 by pressing the **MODE** key.

Change AL2

- Press the **SHIFT** key to move to the right. The digit you choose will be blinking.
- Update the data by pressing the **UP** key.

Move to the next menu

- Choose **Func.3** by pressing the **MODE** key.
- Choose **Func.4** by pressing the **UP** key.
- Press the **MODE** key to enter the F4-1 menu or RS-485 output as optional specifications. See Analog & RS-485 output manual.

Return to the Measuring mode

- Press the **MODE** key to choose **Func.3** or **Func.4** (option)
- Press the **UP** key once again to return the Measuring mode.

10. Calibration for analog input

In order to maintain long term accuracy, periodical calibration at an interval of about one year is recommended. This calibration allows the user to scale the meter both maximum (MAX) and minimum (ZERO) input value. The use of a calibrated signal source and a reference power source are necessary to perform the calibration of the meter.

Calibration range

Point	Range	Example
ZERO	Zero reference value \pm Max value $\times 10\%$	4mA \pm 1.6mA = 2.4 to 5.6mA
MAX	Max reference value \pm Max value $\times 10\%$	20mA \pm 1.6mA = 18.4 to 21.6mA

NOTE 1: Calibration shall be done within the above-mentioned range. Otherwise, your calibration will not be successful.

NOTE 2: "Err" display: The error message might be caused by inadvertently leaving the signal at the range.

NOTE 3: Calibration shall be done from the ZERO to the MAX in order. Otherwise, your calibration will not be successful.

Table 1: Necessary analog input for calibration

Model name	Input rating	Analog input	
		ZERO side	MAX side
419A-02	DC0 to 99.99mV	DC0mV	DC99.99mV or DC100mV
419A-03	DC0 to 999.9mV	DC0mV	DC999.9mV or DC1V
419A-04	DC0 to 5V	DC0V	DC5V
419A-05	DC0 to 9.999V	DC0V	DC9.999V or DC10V
419A-09	DC1 to 5V	DC1V	DC5V
419A-23	DC0 to 999.9 μ A	DC0 μ A	DC999.9 μ A or DC1mA
419A-29	DC4 to 20mA	DC4mA	DC20mA
419A-29R	DC4 to 20mA	DC4mA	DC20mA

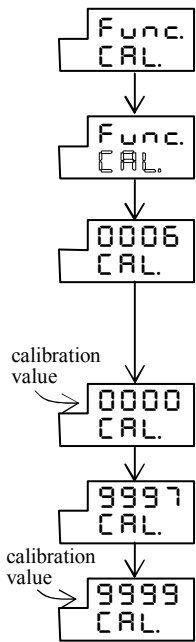

Enter the Calibration mode

- Press the **[MODE]** key for 2 sec or more. **Func.** and **CAL.** blinking and then lit up.

NOTE: If you will release the **[MODE]** key when flashing **Func.** and **CAL.**, return to the Measuring mode.

Choose the Calibration mode

- Each time you press the **[SHIFT]** key, **Func.** and **CAL.** alternately flashes. Choose the **CAL.**

Enter analog input calibration

- Press the **[UP]** key to enter calibration.

NOTE 3: Calibration value will display even though the rate display setting is turned off.

ZERO Calibration

- Connect the appropriate model to the meter. Refer to Table 1.

- Apply the minimum signal to the meter, and then press the **[UP]** key.

- The meter displays 0000 while the meter is accepting the signal as ZERO.

NOTE 4: "0000" display does not mean the setting of the rate offset.

Example: ZERO scales from 6 to 0.

MAX Calibration

- Connect the appropriate model to the meter. Refer to Table 1.

- Apply the maximum signal to the meter, and then press the **[SHIFT]** key.

- The meter displays 9999 while the meter is accepting the signal as MAX.

NOTE 5: "9999" display does not mean the setting of the rate full scale.

Example: MAX scales from 9997 to 9999.

Return to the Measuring mode

- Press the **[MODE]** key for 3 sec or more to success the calibration.

- Then, return the Measuring mode automatically.

11. Dimensions

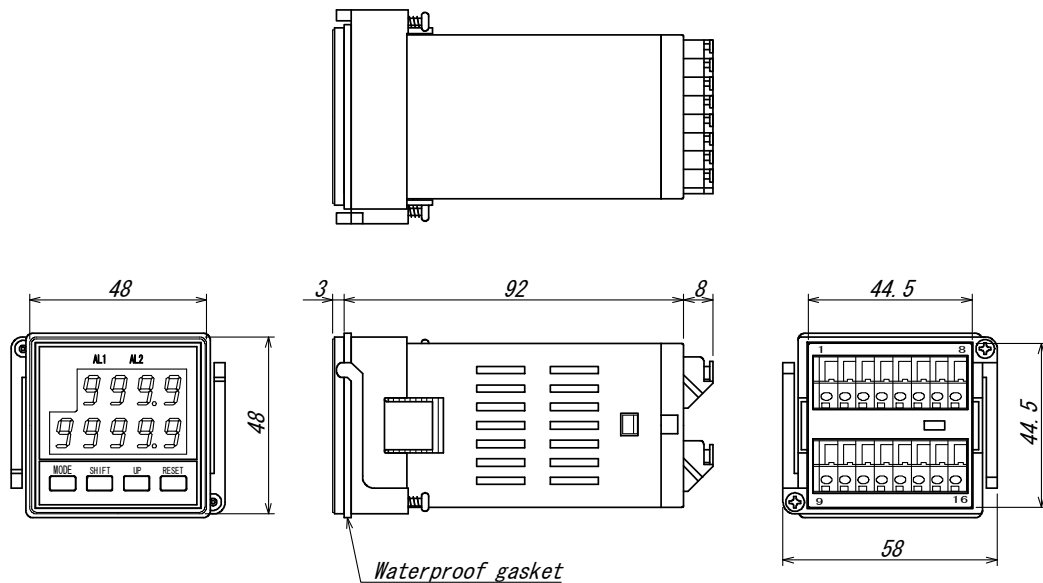

Panel cut dimension: $45^{+0.6/0} \times 45^{+0.6/0}$ mm

Contact Information

Name : Tsuruga Electric Corporation

Address : 1-3-23 Minami-Sumiyoshi, Sumiyoshi-ku, Osaka-shi
558-0041 Japan