

Quick Manual

Digital Meter Relay, Model 452G DC Voltage & Current

I-01902

1. Preface

Thank you for purchasing our digital meter relay 452G series.

Before use, read this manual carefully and thoroughly, and keep this manual available for routine reference.

Please check contents of the package you received as outlined below.

- (1) 452G itself (2) packing (3) This manual (4) Unit label (5) Indication label
(6) Sensor power supply unit (Sensor power supply option) (7) Connector with 2m flat cable (BCD output option)

For safe use of this product, please observe the following warning and caution.

In order to help the users' safe use of the products, the following symbol marks are used in this manual.

WARNING

This is the warning to avoid the danger when it is assumed that such danger as may cause fatal accident or severe injury to a user occurs in case that the product is mishandled.

CAUTION

This is the caution to avoid the danger when it is assumed that such danger as may cause minor injury to a user or generate only physical obstacle occurs in case that the product is mishandled.

WARNING

- There is no power on-off switch on the model 452G. It immediately starts to operate after turning the power.
- Do not touch terminals when turning the power on.

CAUTION

Preserve followings for your safety.

- The rated data is, however, defines with more than 15 minutes warming-up times.
 - When the product is installed in the cabinet, perform the appropriate heat radiation to keep less than 50°C in it.
 - Avoid the close-contacted mounting of the meter relay. The rise of internal temperature affects the life of product.
 - Do not install under the following conditions.
 - Where it is exposed to direct sunlight, dust, corrosive gases, rain, etc.
 - Where ambient temperature or humidity is high.
 - Where it is exposed to excessive noise or static electricity.
 - Where there is constant vibration or shock
 - Store the instrument within the specified temperature range for storage (-20~70°C).
 - When the front panel or the case becomes dirty, wipe it with soft cloth.
- For heavy dirt, wipe it lightly with the soft cloth wetted with the neutral cleaner thinned by water, and finish the cleaning with dry cloth. Do not use organic solvent like benzene or paint thinner as they may deform or discolor the case.

2. Specifications

2.1 Installation Specifications

Power Supply	: AC 100 to 240V (90-250V) 50/60Hz, DC12 to 24V (9-32V)
Power Consumption	: 452G itself Approx. 8.5VA at 100VAC, 10.5VA at 200VAC, 400mA at 12VDC, 200mA at 24VDC. Sensor power supply unit Approx. 7VA at 100VAC, 9VA at 200VAC, 200mA at 12VDC, 100mA at 24VDC.
Comparator output	: Relay output 4-SPST (NO) for AL1 to AL4, and 1-SPDT for GO Contact capacity (resistive): AC250V 1A, DC30V 1A Min. 10 ⁵ electrical operation life (ON-OFF 1200 times / hr) Min. 20x10 ⁶ mechanical operation life (ON-OFF 18000 times / hr) Open Collector output 5-NPN for AL1 to AL4, and GO Contact rating: Max. DC30V 30mA, saturation voltage: Max. DC 1.6V
Operating Temperature	: 0 to 50°C
Storage Temperature	: -20 to 70°C
Weight	: Approx. 300g (60g of the sensor power supply unit)
Mounting Method	: Panel mount with the bracket

2.2 General Specifications

- Display : 0~9999, “-” polarity, with zero-suppress function. ±99999 when calibrating.
 PV: red or green LED (character height 15.2mm)
 SV1 and SV2: red LED (character height 7.6mm)
- Decimal Point : Programmable.
- Over-range indication and err indication : Single input, Blinking with 130% display. When exceeded 9999, blinking with 0000.
 In case of calibration, “Err_A” displays when exceeded 130% of A input.
 “Err_b” displays when exceeded 130% of B.
 “ErrAb” displays when exceeded both A and B.
 When exceeded ±99999, blinking with 00000.
 “Err_Y” is displayed at the calibration error.(At Y=A/B and B=0.)
- Dual input operation : Y=A+B, Y=A-B, Y=A × B, Y=A/B, Y=A × B/10, Y=A × B/100, Y=A × B/1000
- Resolution : 1/10000
- Sampling rate : Approx. 2000 times / sec.
- Insulation Resistance : DC500V 100MΩ or more.
- Withstanding Voltage : Input terminals - Case : AC2000V each for 1 min.
 Power supply terminals - Case : AC2000V each for 1 min.
 Power supply terminals - Input and output terminals : AC1500V each for 1min.
 Input terminals - Output terminals : AC500V each for 1 min.

⚠ CAUTION

•It is not insulated between input A and input B.

Housing protection : IP65 for the front panel, IP20 for the rear case, IP00 for terminals

3. Mounting

Insert the case with the suitable gasket from the panel front.
 Fix the case using the mounting bracket.
 Cut the panel to mount the case in accordance with the illustration.

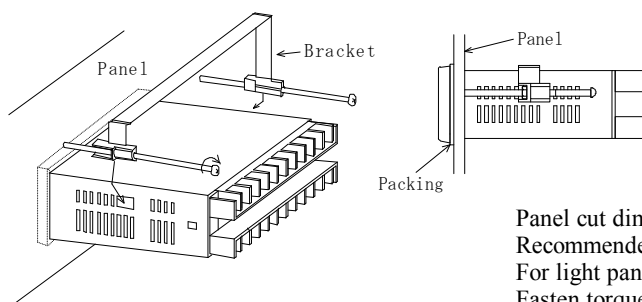

Panel cut dimension: $92^{+0.8/0} \times 45^{+0.6/0}$ mm
 Recommended panel thickness is 0.6 to 6mm.
 For light panel, such as aluminum, should be 1.5mm or more to avoid deform.
 Fasten torque of the mounting bracket is 0.2 to 0.3N·m.

⚠ CAUTION

- Do not over tighten the mounting bracket.
- When plural mounting, pay attention to ventilation to cool down in the panel.

4. Nomenclature

4.1 Front panel

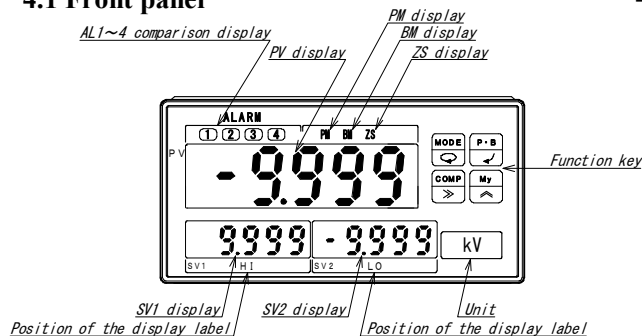

4.2 Function key

- MODE** (circular arrow icon) Switch the measuring, the parameter setting, and the calibration mode.
 (circular arrow icon) Switch modes during the parameter setting mode.
- P·B** (curved arrow icon) Switch indications during the measuring mode.
 (curved arrow icon) Enter the input value during the parameter setting mode.
- COMP** (right arrow icon) Switch alarm points during the measuring mode.
 (right arrow icon) Shift among the digits during the parameter setting mode.
- My** (up arrow icon) Switch to My mode during the measuring mode.
 (up arrow icon) Change values during the parameter setting mode.

4.3 Rear panel

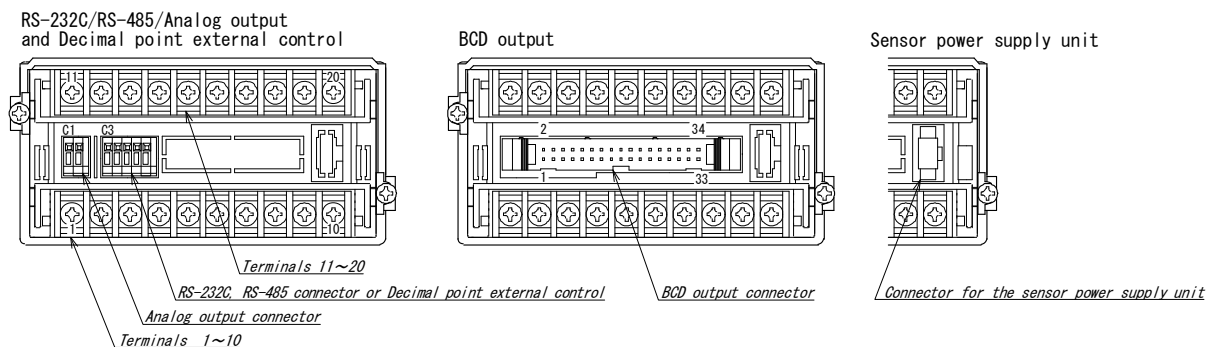

5. Connections

5.1 Terminals and Connections

⚠ WARNING
<ul style="list-style-type: none"> To avoid an electrical shock, turn the power off when wiring. Do not wire with moistened hands. Locate away from the wet place. Do not touch terminals when turning the power on.
⚠ CAUTION
<ul style="list-style-type: none"> Power supply and load should be within the suitable range. Power supply should be rapidly reach the rated power within few seconds. When the power is turned OFF and ON again soon after, provide the downtime of 10 seconds or more. Do not miswiring.

• Note for wiring

- (1) Lay the input cable and the power cable separately.
 Otherwise indication may be fluctuated.
- (2) Provide appropriate noise protection when operating solenoid or large relay by using the relay output.
 Sealed case or power line filter or isolated transformer may be effective.
- (3) COM, L/S, ZS, MR and ALRESET terminals are not insulated.
 Terminals shall be wired to photo coupler, relay, switch, and so on.
 Each meter shall be insulated when plural mounting.

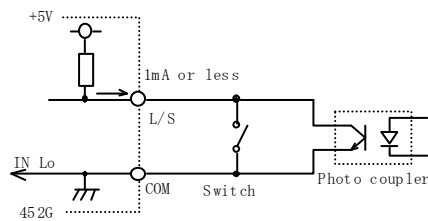

■ Terminals

Terminals are not insulated from the input.

Active "L" $I_{IL} \leq -1\text{mA}$, "L"=0~1.5V, "H"=3.5~5V

- Latch /Synchronization (L/S) : Displayed data, data output, current value, peak memory, bottom memory, display amplitude and comparator output.
Hold the data when the L/S input is active.
- Zero Setting (ZS) : Offset the electrical input value at ZERO.
The ZS LED is lit when the Zero set function is effective.
- Memory Reset (MR) : Rest peak memory, bottom memory, and jump width.
You can reset the memory by turning off or pushing function key.
Minimum pulse width: 10ms
- Alarm Reset (ALRESET) : Release (OFF) alarm outputs and GO outputs.
Minimum pulse width: 10ms

● Terminals

Relay output

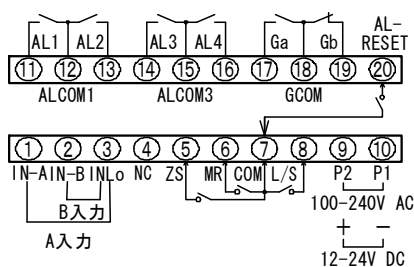

Open collector output(NPN)

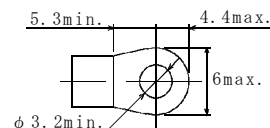
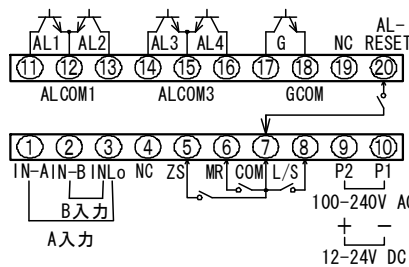

Terminal screws : M3
Fastening torque : 0.46 to 0.62N·m
Crimped terminal : Refer to the figure at the above.

CAUTION

Wire correctly. Unnecessary wiring may cause damage of other equipments, out-of-order, malfunction, and so on.

● Analog output connector

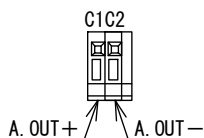

● BCD connector

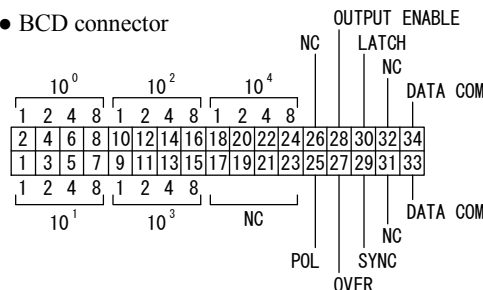

Suitable connector
XG4M-3430-T:OMRON Corp.
with 2m cable

● RS-232C output connector

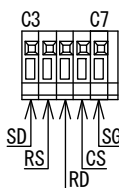

● RS-485 output connector

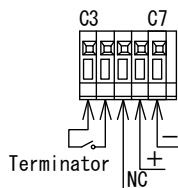

● Decimal point external control connector

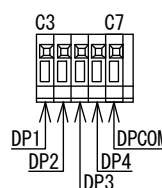

Recommended wire { Solid wire : AWG28 to 22
Twisted wire : AWG28 to 22
O.D. 0.125 min.

Strip-off length: 9 to 10mm

● Sensor power supply unit

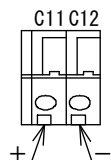

Recommended wire { Solid wire : AWG26 to 16
Twisted wire : AWG22 to 20
O.D. 0.125 min.

Strip-off length: 9mm

5.2 Attaching and detaching of terminal block cover

• Assemble procedures

- (1) Direct the claws of the cover to the terminal blocks. ㉑
- (2) Insert the claw on either side of the cover as the figure shows. ㉒
Insert the claw on another side until it clicks.
Thus, the attaching is completed.

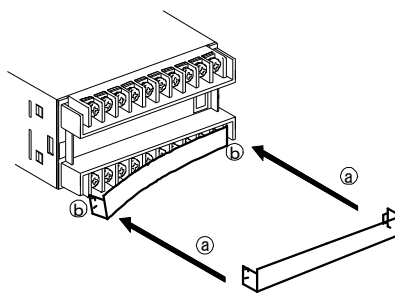

• Disassemble procedures

- (1) Pressing the surface on one side of the cover, slightly slide it downwards. ㉓
- (2) Insert a small screwdriver into the gap made between the side wall of the terminal blocks and the claw of the cover, and stretch it outward. ㉔
- (3) Move whole the cover downwards, then the claw on another side is departed from the terminal blocks. ㉕

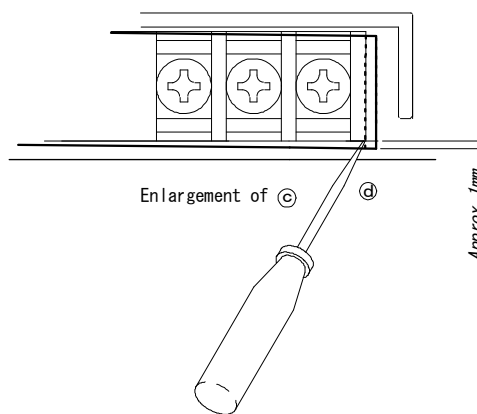
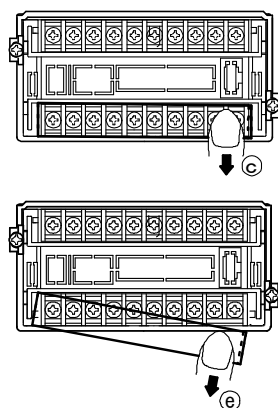

5.3 How to mount the sensor power supply unit (Option)

• Assemble procedures

- (1) Make sure that there is no miswiring to the case.
- (2) Connect the connector of the sensor power supply unit to the case. ㉖
- (3) Hook up the unit to the case. ㉗

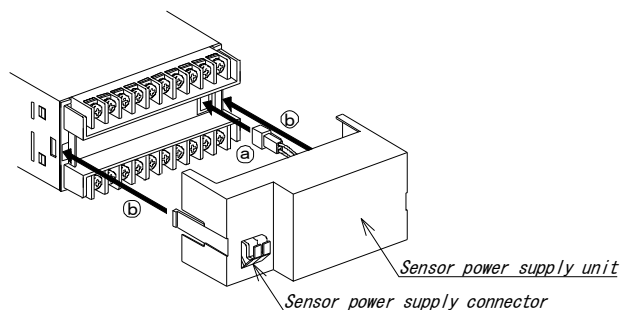

⚠ CAUTION

• Make sure that the supply voltage and serial number matches to that of the case. Wrong voltage or miss-combination will damage the unit.

• Disassemble procedures

- (1) Insert the slotted blade driver to the ㉘ position on the drawing, and turn it outward as ㉙.
- (2) After hooking off the hook of the sensor power supply unit, pull it out as ㉚.
- (3) Disconnect the connector.

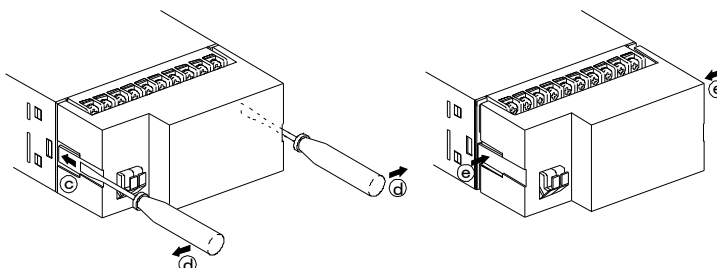

●Key protect

No.	Function	Display	Contents	Default
98	Key protect	PEUPr.	ON, OFF	OFF

● My setting mode

No.	Function	Display	Contents	Default
99	Code registration	114	00 to 98 (00 for non-registration)	

● My setting mode

Registration No.	No.	Function
1	42	AL1
2	43	AL2
3	44	AL3
4	45	AL4
5	02	Offset A
6	03	Full scale A
7	04	Offset B
8	05	Full scale B

6.2 Explanation of function

● Display function

- Parameter 01 : Input/Calibration expression
Select calibration expression at 1-or 2-input.
A, B, A+B, A-B, A × B, A/B, A × B/10, A × B/100, A × B/1000
- Parameter 02, 04 : Scaling offset A,B
Select the scaled offset display reading.
- Parameter 03, 05 : Scaling full-scale A,B
Select the scaled full-scale display reading.
- Parameter 06 : Decimal point
Select the decimal point position.
- Parameter 07 : Average calibration
Select either simple averaging or moving averaging.
- Parameter 08 : Number of averaging sample
Simple: 1,2,4,10,16,33,40,100,120,200,400,1000,2000-time.
Moving: 1,2,4,8,16,32,64,128-time.
- Parameter 09 : Display cycle
Select the display cycle. (Valid only to display. No effect on comparator)
SP1:20ms, SP2:100ms, SP3:400ms, SP4:1s.(When simple average:20ms)
- Parameter 10 : Low cut
Set the width of offset value by low cut, Set to OFF if unnecessary.

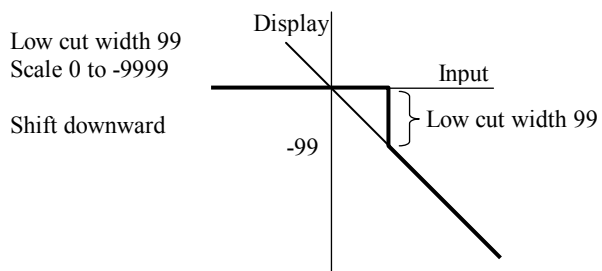
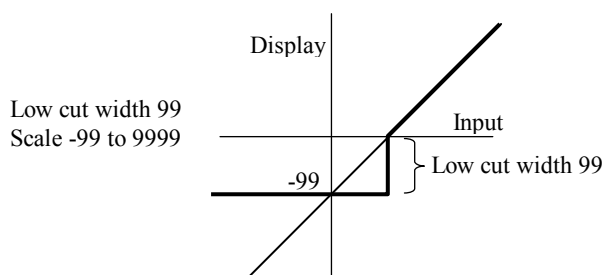
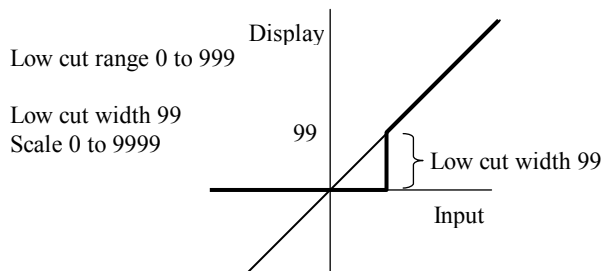

- Parameter 11 : Low cut width
0~999
- Parameter 12 : Indication resolution
Change the resolution of the least significant digit. Step width: 1,2,5,10
(Valid only to display. No effect on comparator)
- Parameter 13 : Extinguished lower digit
Select either lit up or turn off for 10⁻⁰ or 10⁻¹ digit of PV. Comparator outputs at the turn off.
(Valid only to display. No effect on comparator)
- Parameter 14 : Zero setup
Set the initial input value to electrically 0% (offset value) input.
- Parameter 15 : PV indication color
Select the PV indication color, red or green.
- Parameter 16 : SV1 indication value
Select the SV1 indication, lit up or turn off of AL1 to AL4 value.
- Parameter 17 : SV2 indication value
Select the SV2 indication, lit up or turn off of AL1 to AL4 value.
- Parameter 18 : Display turn off
Select the stand-by time of turn off after the end of key operation (PV, SV1, SV2 disappears)
- Parameter 19 : Latch, Synchronization
Select the function of the L/S terminal input: Latch, Synchronization, or 1-sampling synchronization.

● Comparison output

- Parameter 40 : Select the stand-by time for AL 1 to 4 and GO after supplying the power.
- Parameter 41 : Code No.19: When choosing the synchronization at the Latching-Asynchronous measuring function, select any comparison data from existing value, peak memory value, bottom memory vale, and amplitude.
- Parameter 42 to 45 : Select the comparison data of the AL1, AL2, AL3, and AL4.
- Parameter 46 to 49 : Select hysteresis of the AL1, AL2, AL3, and AL4. When the zone is set, it is invalid.
- Parameter 50 to 53 : Select any comparison method of the AL1, AL2, AL3, and AL4 from HI, LO to OFF.
- Parameter 54 : Select the ON delay time for AL 1 to AL 4.
Output delay is ON delay, and outputs upper or lower limit judgment after the delay of your setting time.
- Parameter 55 : Select the OFF delay time for AL 1 to AL 4.
Output delay is ON delay, and breaks upper or lower limit judgment after the delay of your setting time.
- Parameter 56 : Select the comparison condition for AL 1 to AL 4 whether equal NG or equal GO.

Equal NG	Equal GO
Display value ≥ Max. setting value·····HI	Display value > Max. setting value·····HI
Min. setting value < Display value < Max. setting value···GO	Min. setting value ≤ Display value ≤ Max. setting value···GO
Display value ≤ Min. setting value·····LO	Display value < Min. setting value·····LO

- Parameter 57 : Select the judgment of the comparison output whether standard or zone.
- Parameter 58 : Error comparator output
Select the output type of AL1 to AL4 if A or B input overflows: OFF, ON, or last condition (---).
- Parameter 59 : Comparator to last value
Select either enable (ON) or disable (OFF).

● Analog output

- Parameter 78 : Switch the analog output.
Set the display value at the 0% output.
- Parameter 79 : Switch the analog output.
Set the display value at the 100% output.

● RS232C / RS485

- Parameter 80 : Select the Baud rate
- Parameter 81 : Select the Data length.
- Parameter 82 : Select the Parity.
- Parameter 83 : Select the Stop bit.
- Parameter 84 : Disable / Enable the BCC.
- Parameter 85 : Select the Device number.

● Key protect

- Parameter 98 : Key protect
Key protect prevents changes to most of parameters' key operation, such as setting mode, comparison output, PV indication, My setting mode, default value, and calibration mode. "LOCK" appears if touches any key.

● My setting mode

- Parameter 99 : Register well-used 8 code numbers in the setting mode.

Judgment example

Comparator output compares the current value regardless of the display value.

When selecting synchronization, compared data is selectable from the current value, peak memory, bottom memory, and display amplitude.

[Standard setting]

- AL1 (LO setting): 2000
- AL2 (LO setting): 3000
- AL3 (HI setting) : 7000
- AL4 (HI setting) : 8000

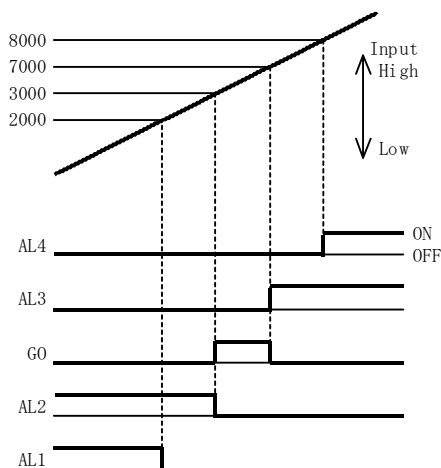

Setting condition

No limitation by varying size of each alarm from AL1 to AL4.

[Zone setting]

- AL1 (LO setting): 2000
- AL2 (LO setting): 3000
- AL3 (HI setting) : 7000
- AL4 (HI setting) : 8000

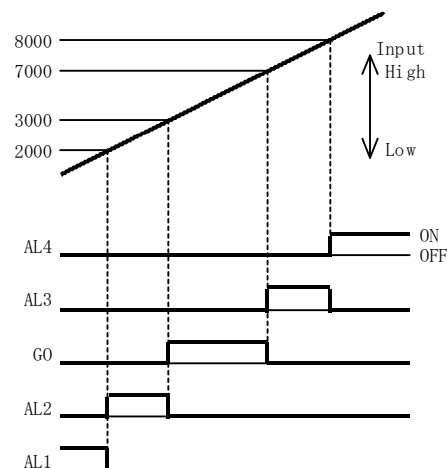

Setting condition

AL1 < AL2 < AL3 < AL4

Hysteresis, output ON delay, and output OFF delay are disable. (enable by setting to 1 to Hysteresis, 0 to ON delay, and 0 to OFF delay)

Comparator of last value

Detect the rapid variation only, and display differences between last and present value. When setting.

Response time of alarm

Response time: (Data calibration time) + (Output time)

Update cycle: It varies averaging time, not synchronize display cycle.

Ex.) Single (1-time) averaging

[In case of single (1) input]

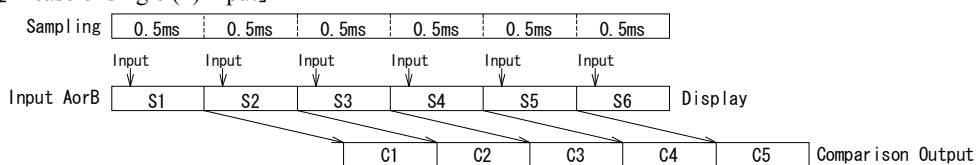

Input capture: each 0.5ms
Output update: each 0.5ms

[In case of dual (2) input]

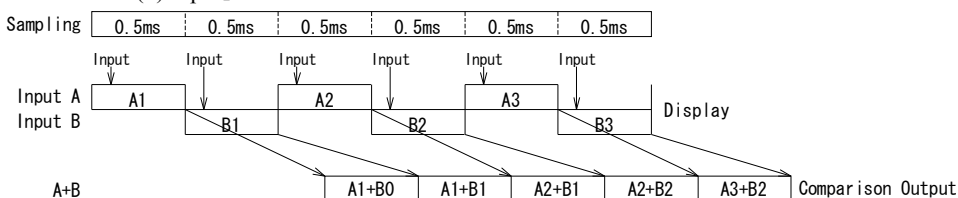

A input capture: each 1ms
B input capture: each 1ms

Output update: each 0.5ms

Averaging times

Select the number of averaging times as a measuring value from the table below.

Averaging	Sampling rate	Noise suppression
1(2000-time/sec.)	0.5ms	-
2(1000-time/sec.)	1ms	-
4(500-time/sec.)	2ms	-
10(200-time/sec.)	5ms	-
16(125-time/sec.)	8ms	-
33(60-time/sec.)	16.6ms	60Hz
40(50-time/sec.)	20ms	50Hz
100(20-time/sec.)	50ms	60Hz
120(16-time/sec.)	60ms	50Hz
200(10-time/sec.)	100ms	50/60Hz
400(5-time/sec.)	200ms	50/60Hz
1000(2-time/sec.)	500ms	50/60Hz
2000(1-time/sec.)	1000ms	50/60Hz

Noise suppression:

Frequency which eliminates noise from utility power frequency.

Display resolution

Select the step width of the resolution of the least significant digit. Valid only to display. No effect on comparator.

Measuring value	0	1	2	3	4	5	6	7	8	9	10	11	12	13	14	15	16	17	18	19
Resolution 1	0	1	2	3	4	5	6	7	8	9	10	11	12	13	14	15	16	17	18	19
Resolution 2	0	2	4	6	8	10	12	14	16	18										
Resolution 5	0	5	10	15	20															
Resolution 10	0	10	20																	

Latch/Synchronization (L/S)

[Latch function]

Keep display value, data output, current value, peak memory, bottom memory, display amplitude, and comparator alarm. Keep datum at active COM level of L/S input.

[Synchronization]

The sampling after L/S activation displays and outputs.

Compared data is selectable from the present value, peak memory, bottom memory, and display amplitudes.

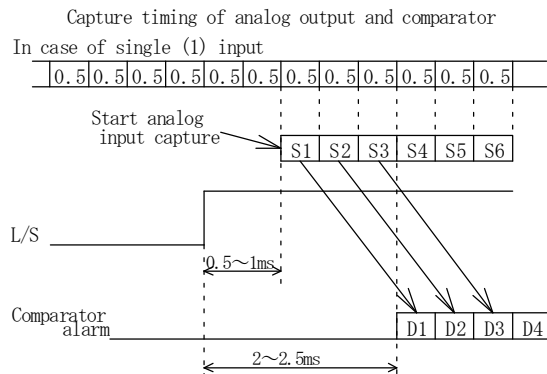
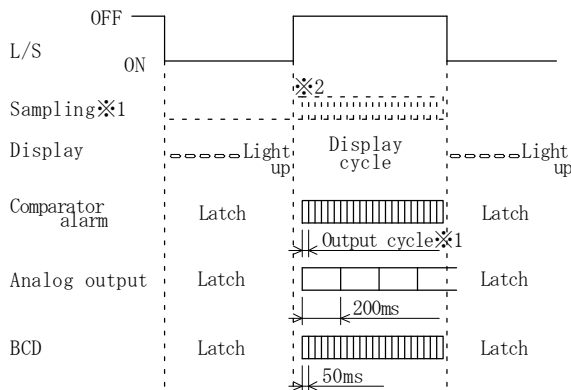

[1-sampling synchronization]

The single sampling only after L/S activation displays and outputs. Compared data is selectable from the present value, peak memory, bottom memory, and display amplitudes.

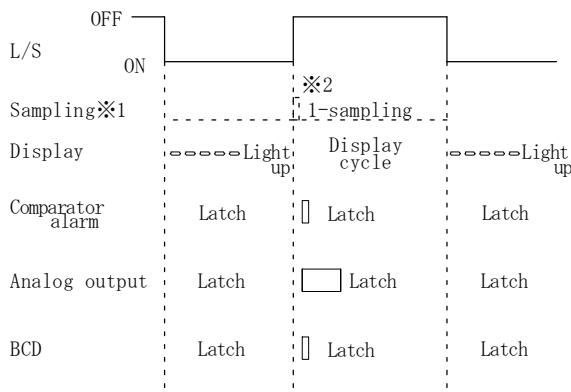

※2 Capture timing of analog input (at 2000-time/sec. Sampling)

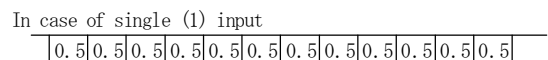

※1 0.5ms × n at simple averaging
0.5ms at moving averaging

7. Parameter Setting

7.1 How to change the comparison setting value

During the measuring mode, the comparison value of the SV1 and SV2 is changeable by pushing **COMP** key.

Setting example: Changes AL3 to 10.20 and AL2 to -11.00 when the comparison setting is AL3 and AL2 for the SV1 and SV2.

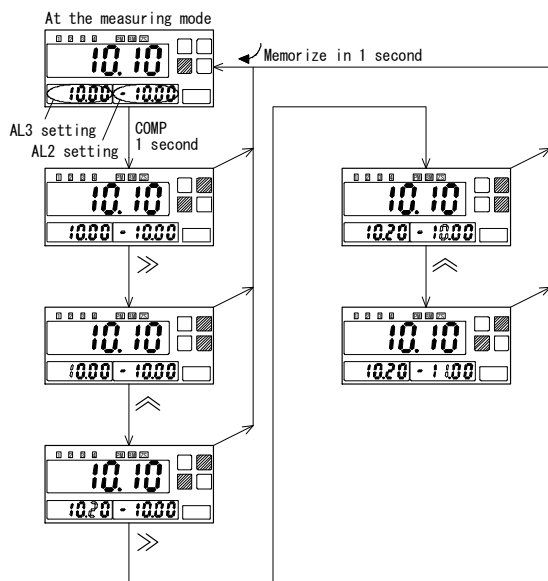

※This function is only available when SV1 and SV2 selecting to comparison setting value.

7.2 PV Display switching

During the measuring mode, the display switches from current value to peak memory, bottom memory, display amplitude, and current value, by pushing **P·B** key.

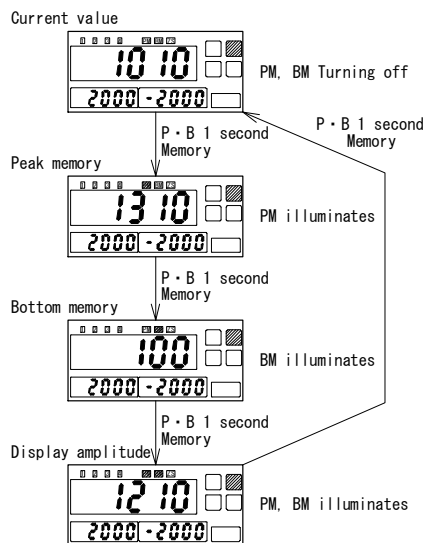

※During If keep the P·B key pushing more than 3 seconds, memory will be reset after switching the display.

7.3 Parameter setting mode

During the measuring mode, the display shows "Cod00" and switches to the parameter setting mode, by pushing the **MODE** key.

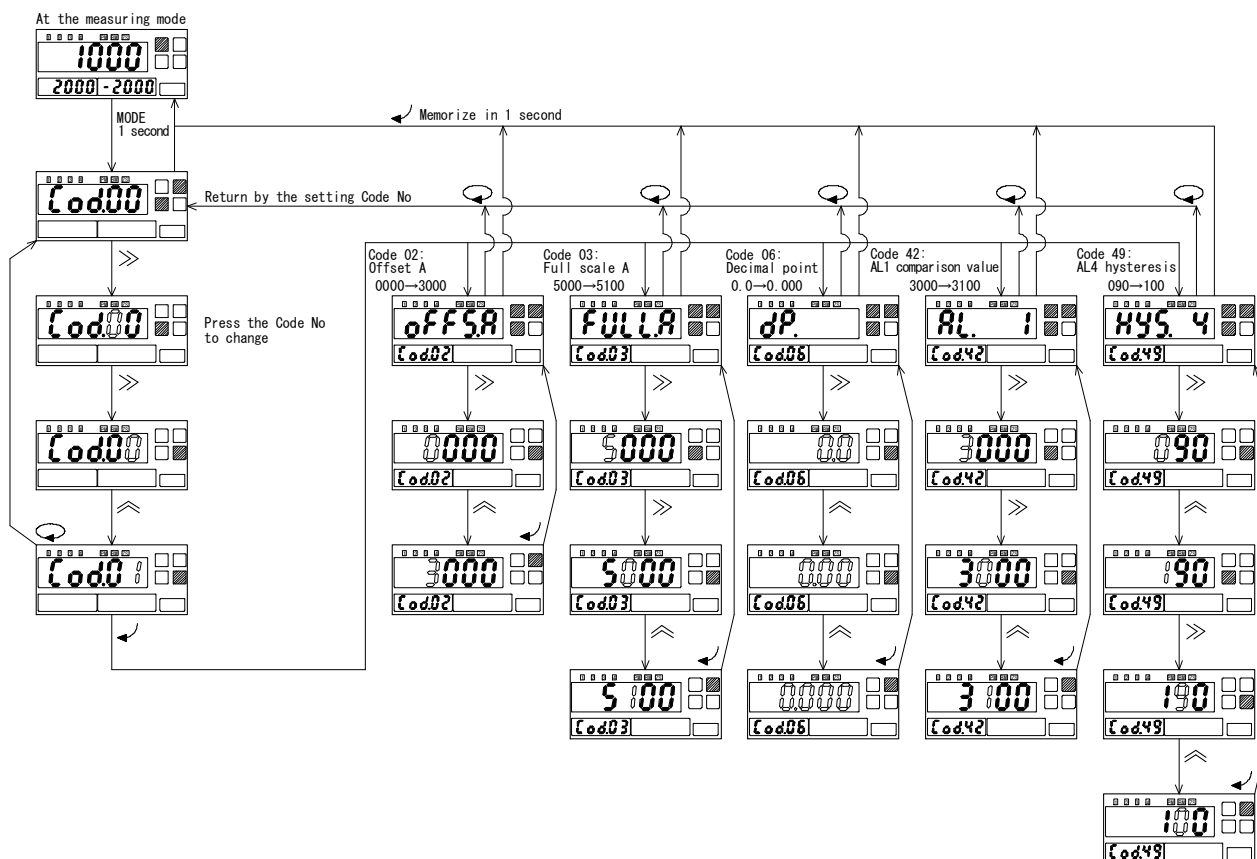

7.5 Calibration mode

This mode is ideal for fine calibration of the display, ZERO and maximum calibration and the optional analog output. During the measuring mode, the display shows “Adj.” and switches the Calibration mode by pushing **MODE** key.

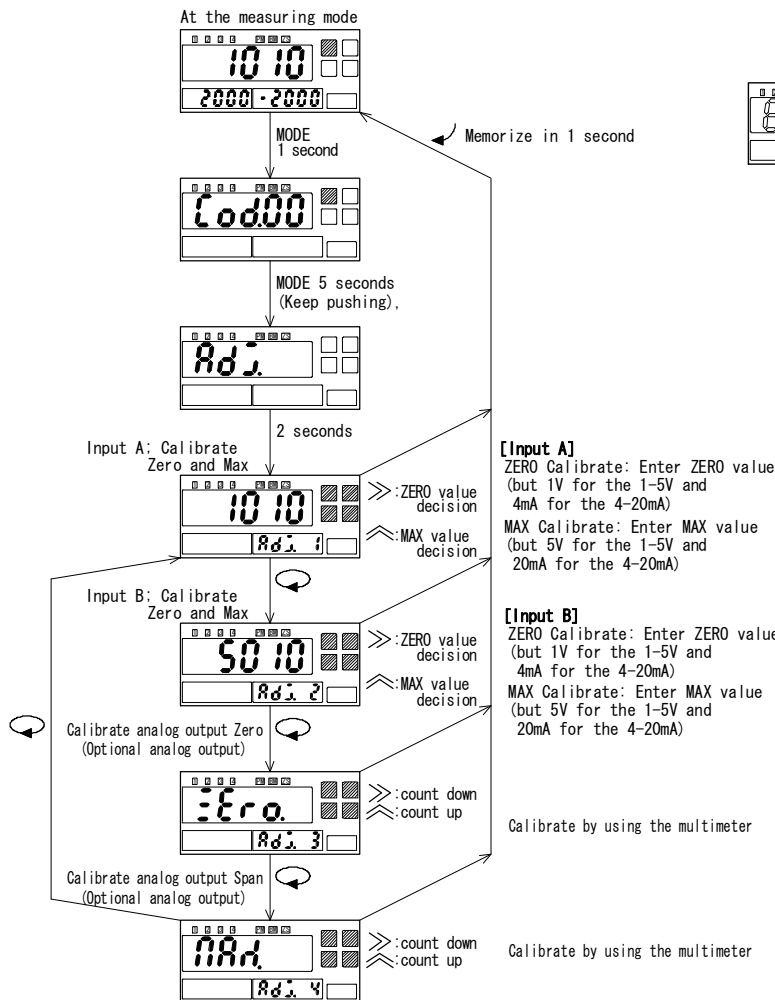

[Input A]
 ZERO Calibrate: Enter ZERO value (but 1V for the 1-5V and 4mA for the 4-20mA)
 MAX Calibrate: Enter MAX value (but 5V for the 1-5V and 20mA for the 4-20mA)

[Input B]
 ZERO Calibrate: Enter ZERO value (but 1V for the 1-5V and 4mA for the 4-20mA)
 MAX Calibrate: Enter MAX value (but 5V for the 1-5V and 20mA for the 4-20mA)

Calibrate by using the multimeter

Calibrate by using the multimeter

7.6 Reset to Default value

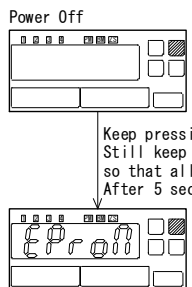

Keep pressing the PB key and turn the power on. Still keep pressing the PB key, so that all LED illuminates and then shuts off. After 5 seconds, release the key.

All parameter resets to default value, and return to the measuring mode.

7.7 Error message

Display	Cause of trouble	Countermeasure
Err 1	Entered Code No. is not applicable.	Enter correct Code No.
Err 2	Entered value is out of range.	Enter correct value.
Err 3	Comparator alarm and analog output scale is out-of-range.	Set within ± 9999 if the parameter 01 is set to A or B.
Err 4	Zero and Max. Calibration is out-of-range at calibration mode.	Set within the range. ($\pm 10\%$)
LoCP	Key protect is set to ON.	Select OFF.
Err A	Input A overflows during calibration.	Reset within the range.
Err b	Input B overflows during calibration.	
Err Ab	Input AB overflows during calibration.	
Err 5	Calibration error.	Set Input B to a value other than 0(zero).

※ During the parameter setting mode and the My setting mode, return automatically to the measuring mode if you do not touch the switch more than 5 minutes. Changed value does not memorize in this case.

7.8 Numeric and Character Indications



8. External Dimensions

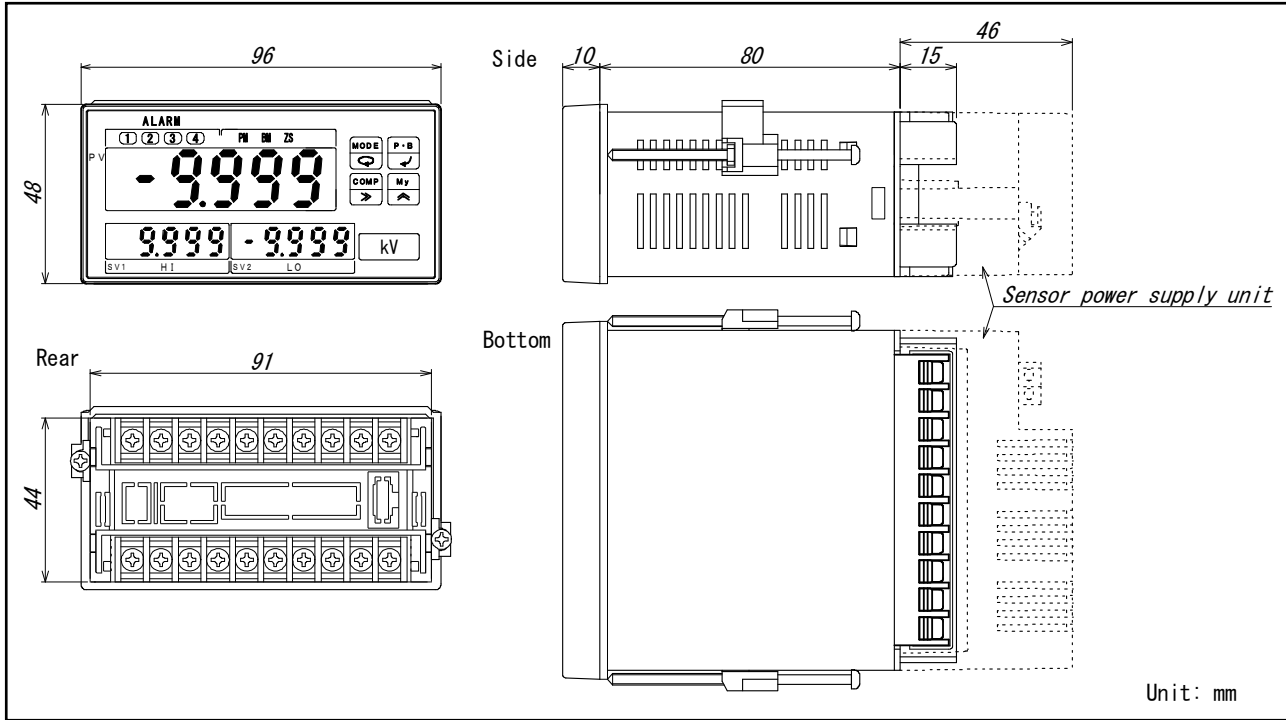

9. Model Numbering

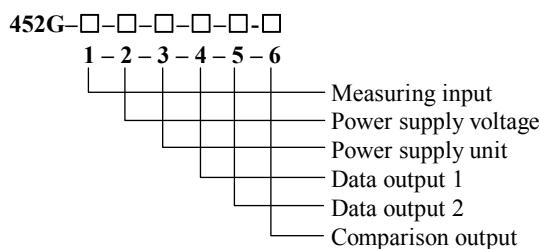

[1] Measuring Input

Model	Measuring Range	Input Resistance	Error *1	Overload
452G-03	±999.9mV	100MΩ	both Input A and B are the same. ±(0.1% FS + 1 digit)	DC±250V
452G-04	±9.999V	1MΩ		DC±250V
452G-V2	DC 0 to 5V	1MΩ		DC±250V
452G-09	DC 1 to 5V	1MΩ		DC±250V
452G-19	DC4 to 20mA	12.4Ω		DC±150mA

both Input A and B are the same.

*1: Error: 23°C±5°C, 45 ~ 75%RH

+1digit is defined within the resolution of 1/10000. (According to the error of IN-A and IN-B, Expression accuracy may expand.)

*2: Thermal effect: ±160ppm/°C It is applied when the operational temperature is 0 to 50°C.

[2] Power Supply Voltage

Code	Power Source Voltage
A	AC100 to 240V
B	DC 12 to 24V

[3] Sensor Power Supply

Code	Power Source Voltage	Output Current
Null	Not provided	-
2	DC +5V ±10%	100mA
3	DC +12V ±5%	150mA *3
5	DC +24V ±5%	100mA *4

*3: 100mA for the DC power supply

*4: 50mA for the DC power supply

[4] Data Output 1

Code	Specifications	Impedance	Max. Load
Null	No output	-	-
09	Analog voltage output. DC 0 to 10 V *5	Max. 0.1Ω	Min. 1kΩ
29B	Analog voltage output. DC 4 to 24 mA *6	Min. 5MΩ	Max. 500Ω
BP	BCD output (TTL level positive logic)	*5: Positive input side outputs. *6: 4mA or less is output up to 0mA.	
BN	BCD output (TTL level negative logic)		
DP	BCD output (transistor output, source type)		
DN	BCD output (transistor output, sink type)		
E0	RS-232C output		
E1	RS-485 output		
EC	External control of decimal point		

[5] Data Output 2

Code	Specifications
Blank	No output
E0	RS-232C
E1	RS-485
EC	External control of decimal point

Valid only with -09 and -29B of the data output 1.

[6] Comparison Output

Code	Specifications
TN	Open collector output (NPN)
RY	Relay output (not possible to combine with analog output -29B.)

Contact Information

Name : Tsuruga Electric Corporation
Address : 1-3-23 Minami-Sumiyoshi, Sumiyoshi-ku, Osaka-shi
558-0041 Japan

Quick Manual

Digital Meter Relay, Model 452G BCD Output

I-01903

1. Data Output Code

Code	Specifications
BP	BCD output (TTL level positive logic)
BN	BCD output (TTL level negative logic)
DP	BCD output (transistor output, source type)
DN	BCD output (transistor output, sink type)

2. Connector and Connections

⚠ WARNING

- To avoid an electrical shock, turn the power off when wiring.
- Do not wire with moistened hands. Locate away from the wet place.
- Do not touch terminals when turning the power on.

⚠ CAUTION

- Do not miswiring. Otherwise, the meter may be broken.

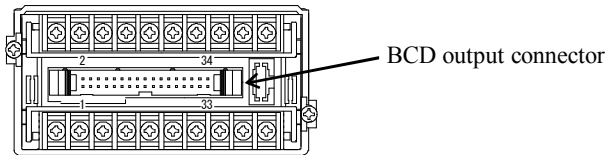

2.1 Connections

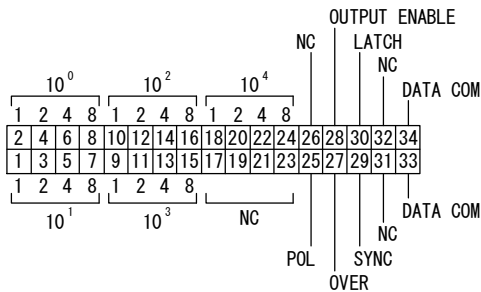

Suitable connector (attached)
XG4M-3430-T:OMRON Corp.
with 2m cable

2.2 TTL output

- Input / Output rating

	Signal	Type -BP	Type -BN	Rating
Output	$\times 10^0$ to $\times 10^4$	Positive logic	Negative logic	TTL level Fo=2 CMOS compatible
	POL	+ =H, - =L	+ =L, - =H	
	OVER	H at over	L at over	
	SYNC	L pulse of 10ms		
Input	LATCH	Hold at L (short-circuit)		$I_{IL} \leq -1\text{mA}$ L = 0 to 1.5V H = 3.5 to 5.0V
	ENABLE	Enable at H (open), Disable at L (short-circuit)		

- Measuring data output ($\times 10^0$ to $\times 10^4$)
Parallel BCD (1-2-4-8) code, latch output. The output is Tri-state type, so a connection to the data bus is easy.
- Polarity Output (POL)
Outputs data polarity to No.25 pin.

● Over Output (OVER)

Outputs over display to No. 27 pin.

1ch input : When exceeded 130% display, outputs both 130% display, POL data and OVER data.
When exceeded 99999, outputs 0 data , POL data and OVER data.

2ch inputs : When exceeded 130% display of the input A, the input B, and both A and B, outputs 0 for data and the over data.
When exceeded +/-99999 or made a processing error, outputs 0 for data and the over data. [POL: +fixed]

● Synchronization (SYNC)

Outputs L pulse of 10ms, which synchronizes display cycle, to No. 29 pin. Readouts the data on the rising edge of this SYNC.
Wired OR connection is possible when connecting several data bus.

● Data enable input (OUTPUT ENABLE)

Outputs datum, includes POL and OVER, when opening (setting to H) No. 28 pin.

When short-circuiting (setting to L) with DATA COM between No. 33 and No.34 pin, DATA, includes POL and OVER, changes to high impedance condition. In this state, SYNC output is prohibited and the connection to the data bus is easy.

● Latch input (LATCH)

Latches BCD data by short-circuiting between No. 30 and DATA COM (No. 33 and No. 34 pins) or setting to L. Display does not latch.

● Data common (DATA COM)

No. 33 and No. 34 pins are common for measuring data output, POL, OVER, SNYC, LATCH, OUTPUT ENABLE.

● NC

Do not use non-occupied NC pin for junction purpose.

●Output switching

BCD output is display data.(current value, peak memory, bottom memory, and display amplitude.)

※Do not apply 5V DC or more due to uniform to TTL level of data output and control signal. Arrange the wiring of data output and control input/output lines apart from the power source line, relays or magnet switches, etc. of big capacity, as well as the input line.

2.3 Transistor output

Wired OR connection is possible for the measuring data, including POL and OVER, and SYNC when connecting several BCD outputs to a PC.

● Input / Output rating

Signal		Item	Type -DP	Type -DN
Output	$\times 10^0$ to $\times 10^4$	Output	Source type	Sink type
	POL OVER SYNC	Output capacity	DC30V 30mA Max., Saturation Voltage: 1.6V Max.	
	LATCH ENABLE	Signal level	Input current: Max. 1mA OFF (H) = 3.5 to 5.0V, ON (L) = 0 to 1.5V	

● Measuring data output ($\times 10^0$ to $\times 10^4$)

Parallel BCD code (1-2-4-8), Latch output.
Transistor turns on (ON) at 1 measuring data.
Transistor turns off (OFF) at 0 measuring data.

● Polarity Output (POL)

Outputs data polarity to No.25 pin.
Transistor turns on (ON) at (+) display value.
Transistor turns off (OFF) at (-) display value.

● Over Output (OVER)

Outputs over display to No. 27 pin.

Transistor turns on (ON) at over display.

1ch input : When exceeded 130% display, outputs both 130% display, POL data and OVER data.
When exceeded 99999, outputs 0 data , POL data and OVER data.

2ch inputs : When exceeded 130% display of the input A, the input B, and both A and B, outputs 0 for data and the over data.
When exceeded +/-99999 or made a processing error, outputs 0 for data and the over data. [POL: +fixed]

● Synchronization (SYNC)

Outputs L pulse of 10ms, which synchronizes display cycle, to No. 29 pin.

Readouts the data on the rising edge (ON→OFF)of this SYNC.

- Data enable input (OUTPUT ENABLE)
Outputs datum, includes POL and OVER, when opening (OFF) No. 28 pin.
When short-circuiting (ON) with DATA COM between No. 33 and No.34 pin, DATA, includes POL and OVER, changes to OFF condition. In this state, SYNC output is prohibited and the connection to the data bus is easy.
- Latch input (LATCH)
Latches BCD data by short-circuiting between No. 30 and DATA COM (No. 33 and No. 34 pins). Display does not latch.
- Data common (DATA COM)
No. 33 and No. 34 pins are common for measuring data output, POL, OVER, SNYC, LATCH, OUTPUT ENABLE.
- NC
Do not use non-occupied NC pin for junction purpose.
- Output switching
BCD output is display data (current value, peak memory, bottom memory, and display amplitude.)

※Arrange the wiring of data output and control input/output lines apart from the power source line, relays or magnet switches, etc. of big capacity, as well as the input line.

3.Example of connection

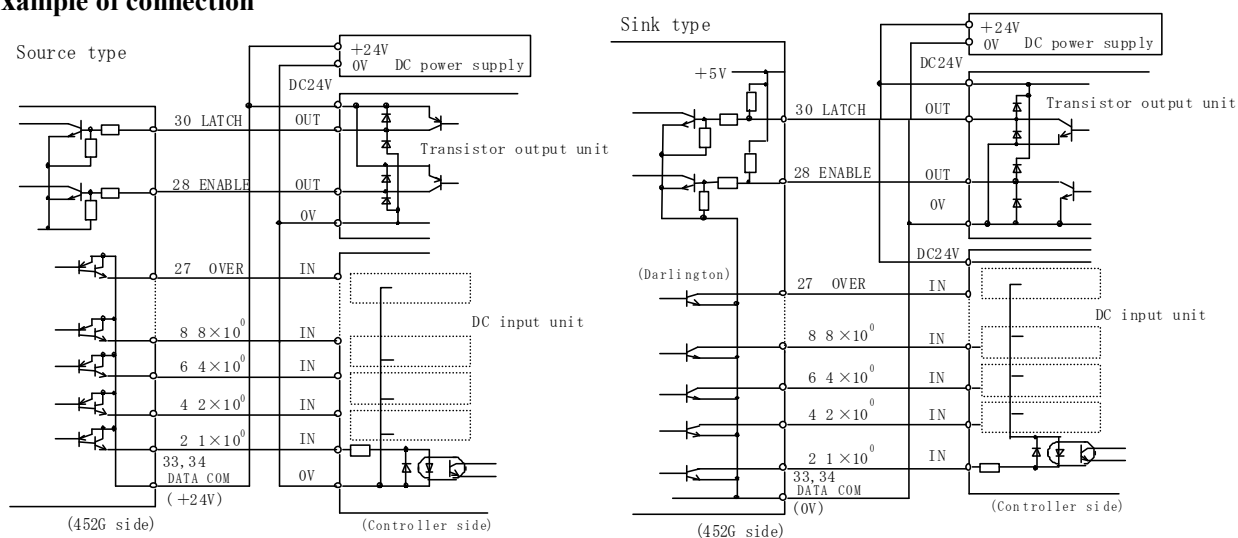

4.Timing chart

●BCD data and LATCH

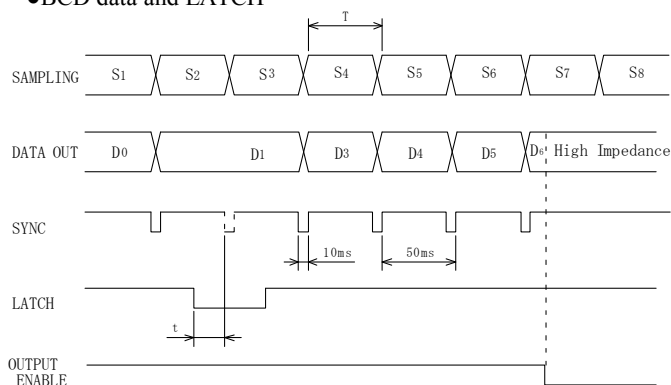

t: Internal operation time approx. 15ms
T: 0.5ms × n at simple averaging.
0.5ms at moving averaging.

●BCD data and L/S

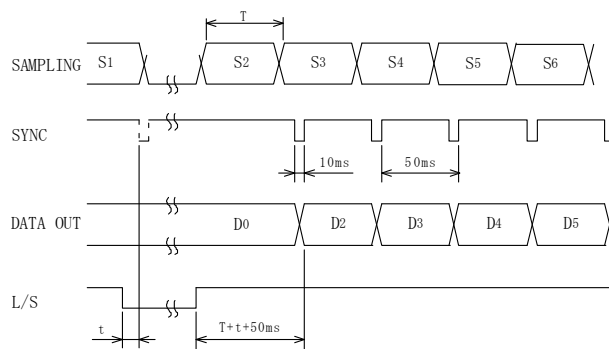

t: Internal operation time approx. 15ms
T: 0.5ms × n at simple averaging.
0.5ms at moving averaging.

Contact Information

Name : Tsuruga Electric Corporation
Address : 1-3-23 Minami-Sumiyoshi, Sumiyoshi-ku, Osaka-shi
558-0041 Japan

Quick Manual

Digital Meter Relay, Model 452G RS-232C / RS-485 Output

I-01905

1. Data Output Code

Code	Output
E0	RS-232C
E1	RS-485

2. Specifications

2.1 Common specifications for RS-232C and RS-485

The measuring input and the RS-232C and RS-485 output is insulated.

Transmission	: Start-Stop half-duplex transmission
Transmission speed	: 4800, 9600, 19200, 38400 bps
Data length	: 7bit / 8bit
Parity	: None, Odd, Even
Stop bit	: 1bit / 2bit
Data	: In conjunction with JIS 8 units code
X parameter	: None
Error detection	: Parity (Choose BCC availability) Operation results of exclusive logic sum just after STX to ETX
Control character	: STX (02H) start of text / ETX (03H) end of text
Device No.	: 00 to 99 Set the device No. to each device, and match each command of device
Transmission character	: Max. 32
Transmission process	: Ignored

452G transmits response in accordance with command frame from the upper PC.

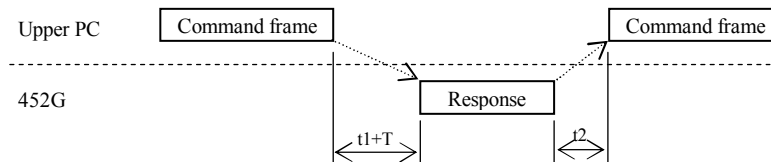

t1: Response time

Measuring datum does not update during response time.

Max. 2.5ms for measuring, judgement, and control command

Max. 3.5ms for setting request command

Max. 6ms for setting assignment command

Max. 100ms for STOR of memory control command

Max. 250ms for DEFAULT of memory control command

T: 10ms of switching time of transmission-reception time for RS485.

t2: Set Min. 50ms waiting time up to the next command transmission after receiving the response.

• RS-485

Connected device numbers: Max. 32, including the upper PC

Line length : Up to 500 m by using shielded twisted-pair cable, AWG28 to 22.

Terminator : Switched by the jumper at the terminal, terminated at 200 Ω

NOTE followings for the use of multi-drop.

- Unify the transmission format.
- Do not duplicate the device number.

3.Connector and Connections

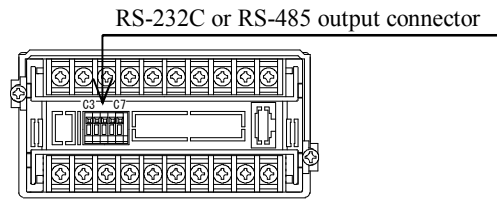

3.1 RS-232C

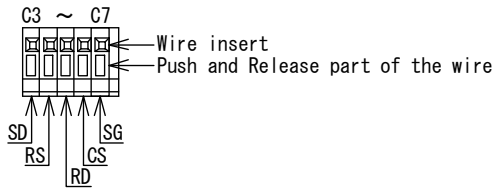

Recommended wire { Solid wire : AWG28 to 22
Twisted wire : AWG28 to 22
O.D. 0.125 min.
Strip-off length: 9 to 10mm

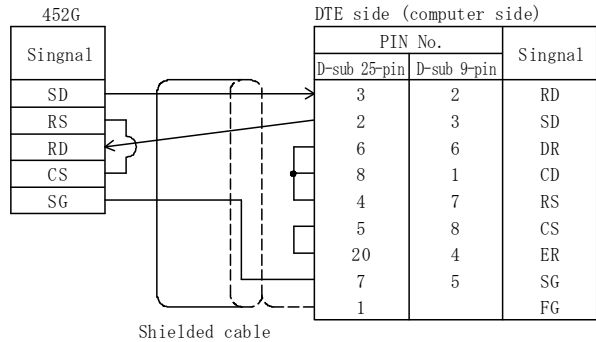

3.2 RS-485

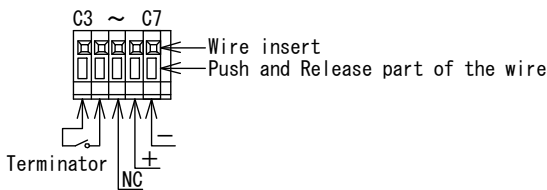

※ Recommended wire { Solid wire : AWG28 to 22
Twisted wire : AWG28 to 22
O.D. 0.125 min.
Strip-off length: 9 to 10mm

※ In case of multi-drop connection, strand twisted wire AWG28 to AWG26 and insert.

Terminator: When short-circuiting the connector, 200Ω resistor is connected in parallel to the line
Input/Output: “+” is non-inverse output, and “-” is inverse output.

● Connection

In case of RS-485 connection, up to 32 devices, includes the upper computer, are possible to connect. Specify the end station for both ends of device on the line. Set the terminator to be short-circuited for the identification of the end station. Lead wire for short-circuit is not attached. Use the converter for another identification to set the terminator.

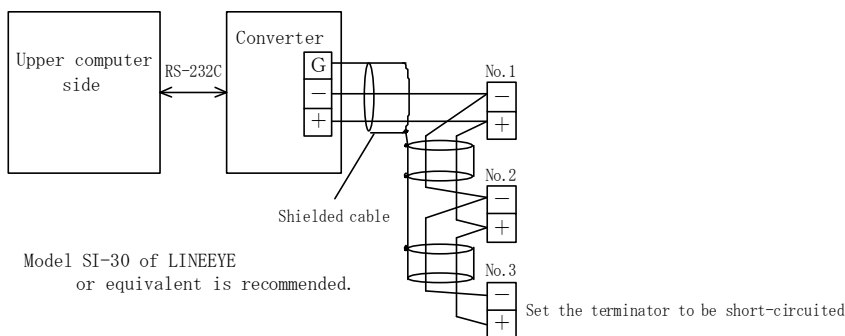

3.3 Communication setting

Use keys on the front panel for communication setting. Refer to I-01902 for key operation.

- Transmission speed, Data length, Parity, Stop bit, BCC availability
- Device number

• Readout the device information

Command : IDNT?, Read out the device information

Response : response to IDNT?

452G-04-09-E0, No.523-000 (Model No. Soft registration No. (Tsuruga))

Command frame

STX	Device No.	I	D	N	T	?	ETX (BCC)
02H	30H	30H	49H	44H	4EH	54H	3FH 03H

Device No. 00

Response End code

STX	Device No.	↓	4	5	2	G	-	0	4	-	0	9	-
02H	30H	30H	41H	34H	35H	32H	47H	2DH	30H	34H	2DH	30H	39H 2DH

E	0	,	N	o	.	5	2	3	-	0	0	0	ETX (BCC)
45H	30H	2CH	4EH	6FH	2EH	35H	32H	33H	2DH	30H	30H	30H	03H

• Readout the judgment

Command : ALARm, Read out the judgment

Response : response to ALARm

16 (GO output)

Command frame

STX	Device No.	A	L	A	R	M	ETX (BCC)
02H	30H	30H	41H	4CH	41H	52H	4DH 03H

Device No. 00

Response End code

STX	Device No.	↓	1	6	ETX (BCC)
02H	30H	30H	41H	31H	36H 03H

• Readout the setting data

Command : RC02, Read out the offset A setting

Response : response to RC02.

0000

Command frame

STX	Device No.	R	C	0	2	ETX (BCC)
02H	30H	30H	52H	43H	30H	32H 03H

Device No. 00

Response End code

STX	Device No.	↓	0	0	0	0	ETX (BCC)
02H	30H	30H	41H	30H	30H	30H	30H 03H

• Set the function command data

Command : WC02_0000, Set the offset A

Response : response to WC02_0000.

0000

Command frame

STX	Device No.	W	C	0	2	-	0	0	0	0	ETX (BCC)
02H	30H	30H	57H	43H	30H	32H	20H	30H	30H	30H	30H 03H

Device No. 00

Response End code

STX	Device No.	↓	0	0	0	0	ETX (BCC)
02H	30H	30H	41H	30H	30H	30H	30H 03H

• Readout the control command data

Command : RLATch, Read out the latching

Response : response to RLATch.

0 (OFF)

Command frame

STX	Device No.	R	L	A	T	C	H	ETX (BCC)
02H	30H	30H	52H	4CH	41H	54H	43H	48H 03H

Device No. 00

Response End code

STX	Device No.	↓	0	ETX (BCC)
02H	30H	30H	41H	30H 03H

• Set the control command data

Command : WLATch_0, Set the latching

Response : response to WLATch_0.
0 (OFF)

Command frame

STX	Device No.	W	L	A	T	C	H	_	0	ETX (BCC)
02H	30H	30H	57H	4CH	41H	54H	43H	48H	20H	30H 03H

Device No. 00

Response End code

STX	Device No.	↓	0	ETX (BCC)
02H	30H	30H	41H	30H 03H

• Memory control command

• Write command: Write the setting data into the EEPROM.

Command : STOR

Response : End code

Command frame

STX	Device No.	S	T	O	R	ETX (BCC)
02H	30H	30H	53H	54H	4FH	52H 03H

Device No. 00

Response End code

STX	Device No.	↓	ETX (BCC)
02H	30H	30H	41H 03H

Normal end

• Memory initialization: Setting datum resets to default, except of transmission speed, data length, parity, stop bit, BCC switch, and device No.

Command : DEFault

Response : End code

Command frame

STX	Device No.	D	E	F	A	U	L	T	ETX (BCC)
02H	30H	30H	44H	45H	46H	41H	55H	4CH	54H 03H

Device No. 00

Response End code

STX	Device No.	↓	ETX (BCC)
02H	30H	30H	41H 03H

Normal end

4.3 Command table

• Setting command

Function	Requested command		Specified command		
	Command	Response	Command frame	Response	Function, range
Input/Calibration expression	RC01	1	WC01_1	1	0:A,1:B,2:A+B,3:A-B,4:A×B,5:A/B 6:A×B/10,7:A×B/100,8:A×B/1000
Scaling offset A	RC02	0000	WC02_0000	0000	-9999~9999
Scaling full-scale A	RC03	9999	WC03_9999	9999	-9999~9999
Scaling offset B	RC04	0000	WC04_0000	0000	-9999~9999
Scaling full-scale B	RC05	9999	WC05_9999	9999	-9999~9999
Decimal point	RC06	0	WC06_0	0	0:0,1:0.0,2:0.00,3:0.000
Average Calibration	RC07	0	WC07_0	0	0: Simple averaging,1: Moving averaging
Frequency of average calibration	Simple averaging	0	WC08_0	0	0:1,1:2,2:4,3:10,4:16,5:33,6:40,7:100,8:120, 9:200,10:400,11:1000,12:2000
	Moving averaging				
Display cycle	RC09	1	WC09_1	1	0:20ms,1:100ms,2:400ms,3:1s
Low cut	RC10	0	WC10_0	0	1:ON,0:OFF
Low cut value	RC11	000	WC11_099	099	0~999
Indication resolution	RC12	1	WC12_3	3	0:1,1:2,2:5,3:10
Turn off lower digit	RC13	1	WC13_0	0	0:Lit up,1:10 ⁰ digits turn off, 2:10 ⁰ digit and 10 ¹ digit is turn off.
Zero setup	RC14	0	WC14_1	1	1:ON,0:OFF
PV indication color	RC15	1	WC15_3	3	0:RR,1:RG,2:GR,3:GG
SV1 indication value	RC16	3	WC16_0	0	0:OFF,1:AL1,2:AL2,3:AL3,4:AL4
SV2 indication value	RC17	2	WC17_1	1	0:OFF,1:AL1,2:AL2,3:AL3,4:AL4
Display turn off (Turn off time setup for PV, SV1 & SV2)	RC18	1,1,1,99	WC14_1,1,1,99	1,1,1,99	1:ON,0:OFF,0~99
Latch, Synchronization	RC19	1	WC19_0	0	0: Latch,1: Synchronization, 2: One sampling synchronization
Power on delay	RC40	2	WC40_99	99	2~99
Comparison data	RC41	5	WC41_5	5	5:RM (6:PM,7:BM,8:PB) Note1)
AL1 Comparison value	RC42	2000	WC42_99999	99999	-99999~99999 Note2)
AL2 Comparison value	RC43	3000	WC43_99999	99999	-99999~99999 Note2)
AL3 Comparison value	RC44	7000	WC44_99999	99999	-99999~99999 Note2)
AL4 Comparison value	RC45	8000	WC45_99999	99999	-99999~99999 Note2)
AL1 Hysteresis	RC46	1	WC46_999	999	1~999
AL2 Hysteresis	RC47	1	WC47_999	999	1~999
AL3 Hysteresis	RC48	1	WC48_999	999	1~999
AL4 Hysteresis	RC49	1	WC49_999	999	1~999
AL1 Comparison method	RC50	0	WC50_0	0	0:OFF,1:HI,2:LO
AL2 Comparison method	RC51	2	WC51_2	2	0:OFF,1:HI,2:LO
AL3 Comparison method	RC52	1	WC52_1	1	0:OFF,1:HI,2:LO
AL4 Comparison method	RC53	0	WC53_0	0	0:OFF,1:HI,2:LO
Output ON delay	RC54	0	WC54_99	99	0~99
Output OFF delay	RC55	20	WC55_1.00	20	0:0.0,1:0.05,2:0.1,3:0.15,4:0.2,5:0.25,6:0.3, 7:0.35,8:0.4,9:0.45,10:0.5,11:0.55,12:0.6, 13:0.65,14:0.7,15:0.75,16:0.8,17:0.85,18:0.9, 19:0.95,20:1.00sec
Comparison conditions	RC56	0	WC56_1	1	1:GO,0:NG
Zone setting	RC57	0	WC57_1	1	1:ON,0:OFF
Error comparator output	RC58	0	WC58_1	1	1:ON,0:OFF,2:---
Comparator to last value	RC59	0	WC59_1	1	1:ON,0:OFF
Analog output offset	RC78	00000	WC78_99999	99999	-99999~99999 Note2)
Analog output full scale	RC79	19999	WC79_99999	99999	-99999~99999 Note2)
Key protect	RC98	0	WC98_1	1	1:ON,0:OFF
Code registration of My setting mode	RC99	42,43,44,45, 01,02,03,00	WC99_42,43,44,45, 01,02,03,00	42,43,44,45, 01,02,03,00	00~98

Note1) Available when choosing synchronization to the code No.19.

Note2) Setting range is +/-9999 when choosing A and/or B to the code No.01.

• Measuring command

Function	Requested command	
	Command	Response
Current value data	DATA?	+0.9999E+1,16
Current value data	RMREad	+0.9999E+1
Peak data	PMREad	+0.9999E+1
Bottom data	BMREad	+0.9999E+1
Amplitude data	PBREad	+0.9999E+1

Note) In case of 2ch display, A+B, A-B, A*B, A/B, A*B/10, A*B/100, A*B/1000, response data is measuring over and 0 value when exceeding rated input or scale.

• Judgment command

Function	Requested command			
	Command	Response	Output	Item
AL1 to AL4, GO	ALARm	16 (00 at ALRESET)	AL1 AL2 AL3 AL4 GO	Weight of data 01 02 04 08 16

• Control command

Function	Requested command		Specified command		
	Command	Response	Command frame	Response	Item
Latch	RLATch	1	WLATch 1	1	1:ON, 0:OFF
Latch, Synchronization	RHOLd	0	WHOLd 1	1	1:ON, 0:OFF
Alarm reset	RALRst	1	WALRst 1	1	1:ON, 0:OFF
Memory reset			MR	End code	

• Memory control command

Function	Requested command		Specified command		
	Command	Response	Command frame	Response	Item
Write			STOR	End code	
Default			DEFAult	End code	

Contact Information

Name : Tsuruga Electric Corporation
 Address : 1-3-23 Minami-Sumiyoshi, Sumiyoshi-ku, Osaka-shi
 558-0041 Japan

Quick Manual

Digital Meter Relay, Model 452G Analog Output

I-01904

1. Data Output Code

Code	Specifications	Output Impedance	Max. Load
09	Analog voltage (positive input side outputs) * DC 0-10V	Max. 0.1 Ω	Min. 1k Ω
29B	Analog current (positive input side outputs) DC 0-20mA	Min. 5M Ω	Max. 500 Ω

* Outputs the positive input side

Example: Input signal is $\pm 9.999V$,
and analog output is 0 to 10V DC.

Input	Analog output
0V	0V
9.999V	10V

2. Connector and Connections

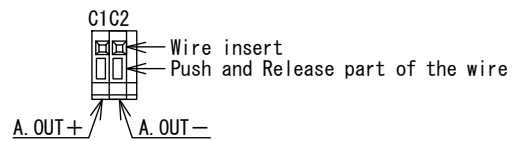
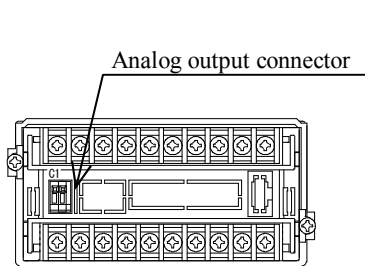

Recommended wire (Solid wire : AWG28 to 22
Twisted wire : AWG28 to 22
O.D. 0.125 min.)

Strip-off length: 9 to 10mm

Outputs voltage or current is in proportional to input signal.

⚠ CAUTION

●Do not apply voltage to the analog output connector. Otherwise, the meter may be broken.

3. Functions

Refer to our Quick manual, I-01902, for detailed setting procedures.

- Output switching : Analog output is display data (data from current value, peak memory, bottom memory, and display amplitude.)
- Offset / Full scale : (Parameter 78 and 79) Set the display value at the 0% input and 100% input. The offset value may be lower or higher than the full scale value.

Example 1: Input: $\pm 9.999V$, Scale: 0 to 9999

Output 0-10V in proportional to 0 ~ 1000 display.

Setting of analog scale: Parameter 78...0

Parameter 79...1000

Input	Display	Analog output
0.0V	0	0.000V
0.5V	500	5.000V
1.000V	1000	10.000V
9.999V	9999	10.000V

Example 2: Input: 1 to 5V, Scale: 1000 to 5000

Output 1-5V in proportional to 1000 ~ 5000 display.

Setting of analog scale: Parameter 78...0

Parameter 79...9999

Input	Display	Analog output
0.0V	0	0.000V
1.0V	1000	1.000V
5.0V	5000	5.000V
6.2V	6200	6.200V
6.2V is exceeded	6200 Blinking	6.200V

Note) In case of Input expressions display (A+B, A-B, A*B, A/B, A*B/10, A*B/100, A*B/1000), outputs 10V when exceeding rated input or scale.

Example 3: Input: 0 to 5V, Scale: 0 to 3000

Output 4-20mA in proportional to 0 ~ 3000 display.

Setting of analog scale: Parameter 78...0

Parameter 79...3000

Input	Display	Analog output
0.0V	0	4.00mA
5.0V	3000	20.00mA

Note) In case of Input expressions display (A+B, A-B, A*B, A/B, A*B/10, A*B/100, A*B/1000), outputs 20mV when exceeding rated input or scale.

4. Calibration

In order to maintain long term accuracy, periodical calibration at an interval of about one year is recommended.

Make a calibration in the ambient condition of $23^{\circ}\text{C} \pm 5^{\circ}\text{C}$, 75%RH or less.

Refer to our Quick manual, I-01902, for detailed calibration procedures.

5. Specifications

The measuring input and the analog output is insulated. Outputs the positive input side.

Conversion : PWM conversion system

Allowable Error : $\pm 0.15\%$ of Span at $23^{\circ}\text{C} \pm 2^{\circ}\text{C}$

Temperature coefficient : $\pm 200\text{ppm}/^{\circ}\text{C}$

Linearity : 0.1 % of Span

Resolution : 1/10000 (When analog scale is 10000 or more.)

Output periodicity : 200ms

Contact Information
Name : Tsuruga Electric Corporation
Address : 1-3-23 Minami-Sumiyoshi, Sumiyoshi-ku, Osaka-shi 558-0041 Japan

Quick Manual

Digital Meter Relay, Model 452G Special Analog Output

I-01907

1. Data Output Code

Code	Specifications	Output Impedance	Max. Load
13	Analog voltage (positive input side outputs) DC 0-±1V	Max. 0.1 Ω	Min. 100 Ω
15	Analog voltage (positive input side outputs) DC 0-±10V	Max. 0.1 Ω	Min. 1k Ω

Example: Input signal is ±9.999V, and analog output is 0-1V DC.

Input	Analog output 13	Analog output 15
-9.999V	-1V	-10V
0V	0V	0V
9.999V	1V	10V

2. Connections

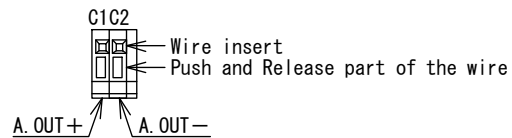
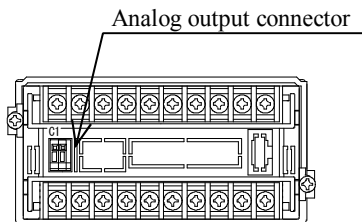

Recommended wire (Solid wire : AWG28 to 22
Twisted wire : AWG28 to 22
O.D. 0.125 min.

Strip-off length: 9 to 10mm

Outputs voltage is in proportional to input signal.

⚠ CAUTION

●Do not apply voltage to the analog output connector. Otherwise, the meter may be broken.

3. Functions

Refer to our Quick manual, I-01902, for detailed setting procedures.

- Output switching : Analog output is display data (data from current value, peak memory, bottom memory, and display amplitude.)
- Offset / Full scale : (Parameter 78 and 79) Set the display value at the 0% input and 100% input. The offset value may be lower or higher than the full scale value.

Example 1: Input: ±9.999V, Scale: 0 to 9999
Output 0-1V(-13) in proportional to 0-1000 display.
Setting of analog scale: Parameter 78...0
Parameter 79...1000

Input	Display	Analog output
-9.999V	-9999	-1.000V
-1.000V	-1000	-1.000V
-0.5	-500	-0.500V
0.0V	0	0.000V
0.5V	500	0.500V
1.000V	1000	1.000V
9.999V	9999	1.000V

Example 2: Input: ±9.999V, Scale: 0 to 9999
Output 1-5V(-15) in proportional to -1000-1000 display.
Setting of analog scale: Parameter 78...-1500
Parameter 79...3500

Input	Display	Analog output
-9.999V	-9999	-10.00
-1.500V	-1500	0.00V
-1.000V	-1000	1.00V
-0.5V	-500	2.00V
0.0V	0	3.00V
0.5V	500	4.00V
1.000V	1000	5.00V
3.500V	3500	10.00V
9.999V	9999	10.00V

Note) In case of Input expressions display (A+B, A-B, A*B, A/B, A*B/10, A*B/100, A*B/1000), outputs maximum voltage (+1V for -13, +10V for -15) when exceeding rated input or scale.

4. Calibration

In order to maintain long term accuracy, periodical calibration at an interval of about one year is recommended.

Make a calibration in the ambient condition of $23^{\circ}\text{C} \pm 5^{\circ}\text{C}$, 75%RH or less. Refer to our Quick manual, I-01902, for detailed calibration procedures.

5. Specifications

The measuring input and the analog output is insulated.

Conversion	: PWM conversion system
Allowable Error	: $\pm 0.15\%$ of Span at $23^{\circ}\text{C} \pm 2^{\circ}\text{C}$
Temperature coefficient	: $\pm 200\text{ppm}/^{\circ}\text{C}$
Linearity	: 0.1 % of Span
Resolution	: 1/10000 (for -13: -1V to 1V DC and -15: -10 to 10V DC output)
Output periodicity	: 200ms

Contact Information
Name : Tsuruga Electric Corporation
Address : 1-3-23 Minami-Sumiyoshi, Sumiyoshi-ku, Osaka-shi 558-0041 Japan

Quick Manual

Digital Meter Relay, Model 452G Decimal Point External Control

I-01906

1. Data Output Code

Code	Specifications
EC	Decimal point external control

2. Connector and Connections

⚠ WARNING

- To avoid an electrical shock, turn the power off when wiring.
- Do not wire with moistened hands. Locate away from the wet place.
- Do not touch terminals when turning the power on.

⚠ CAUTION

- Do not miswriting. Otherwise, the meter may be broken.

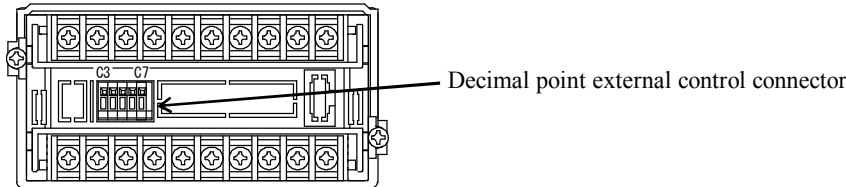

2.1 Connections

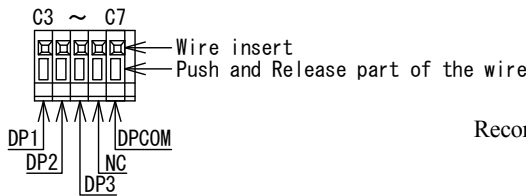

Recommended wire { Solid wire : AWG28 to 22
Twisted wire : AWG28 to 22
O.D. 0.125 min.

Strip-off length: 9 to 10mm

2.2 Specifications

- Setting: Decimal point is programmable from the front panel or external control.
 - Front panel setting: selectable by the front panel key. Refer to the quick manual, I-01902 for the 452G.
 - External control (DP1 to DP3)
- Decimal point is programmable at your desired position by setting the external control mode.
Short-circuit between 10^1 to 10^3 digit (DP1 to DP3) and DPCOM (Active "L").
Decimal point does not light up when overlapping DP1 to DP3 one another.

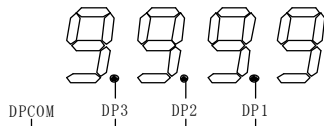

- Electrical specifications: Input terminal and external control terminal are insulated.
Those are insulated from ZS, MR, and L/S terminal.
Active "L", $I_{IL} \leq -1\text{mA}$, "L"=0 to 0.8V, "H"=3.5 to 5.0V

2.3 Input circuit

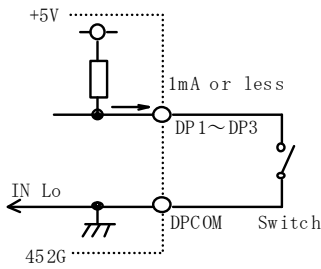

2.4 Function

Programmable external control by selecting OUT for the decimal point.

No.	Function	Display	Contents	Default
03	Decimal point	dP.	0, 0.0, 0.00, 0.000, OUT	OUT

2.5 Parameter setting mode

During the measuring mode, the display shows “[Cod00]” and switches to the parameter setting mode, by pushing the **MODE** key.

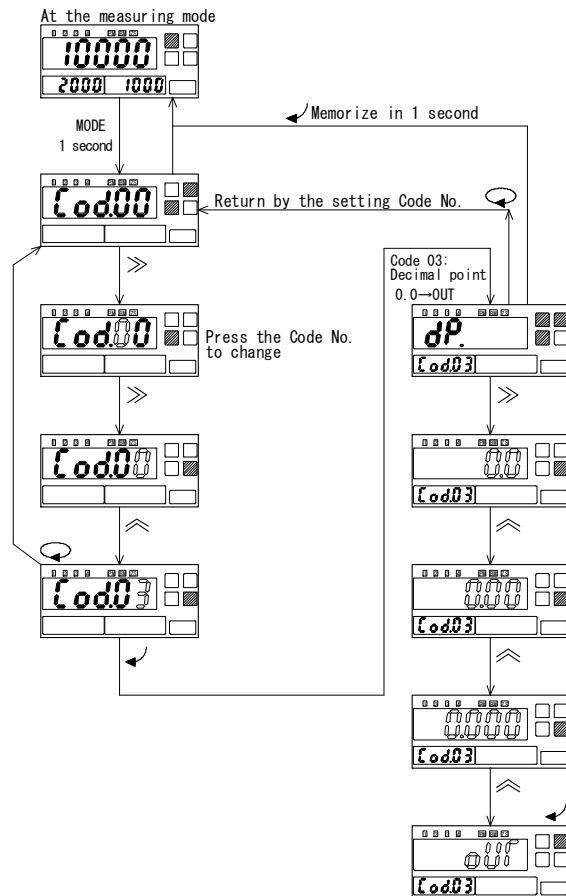

Contact Information

Name : Tsuruga Electric Corporation
 Address : 1-3-23 Minami-Sumiyoshi, Sumiyoshi-ku, Osaka-shi

558-0041 Japan