

MODEL 461A

**Digital Panel Meter
With
Totalizer Function**

Instruction Manual

I-01586

TSURUGA ELECTRIC CORPORATION

Contents

1. Preface	1
2. For safety use	1
3. Initial setting at factory	1
4. Standard specifications	2
4.1 Model designation	2
4.2 General specifications	3
4.3 Dimensions	4
5. Installation	4
6. Setting of each function	5
6.1 Name of parts	5
6.2 Function of setting switches	5
6.2 Function and change method	6
6.3.1 Change-over of pause (temporary stop input) / Latch function	6
6.3.2 Selection of blinking at over-range of totalized value display	6
6.3.3 Change-over of totalizer reset function	6
6.4 Preset output (AL1~4OUT, ALCOM)	Optional specifications ... 8
6.5 LED display mode	10
6.6 Totalizing constant	10
6.7 Initial totalizing value	11
6.8 Instantaneous value measurement full scale	11
6.9 Instantaneous value offset	12
6.10 Instantaneous value measurement sampling rate	12
6.11 Decimal point of instantaneous and totalized value	13
6.12 Cut-off	14
6.13 Totalization-synchronized pulse	15
6.14 Analog output constant	Optional specifications... 16
6.15 Change of totalized value alarm output and batch output mode	Optional specifications... 17
6.16 AL1 Low alarm limit of instantaneous value	Optional specifications... 18
6.17 AL2 High alarm limit of instantaneous value	Optional specifications... 18
6.18 AL3 High alarm limit of totalized value, or pre-warning batch output ..	Optional specifications... 19
6.19 AL4 Higher High alarm limit of totalized value, or stop batch output ...	Optional specifications... 19
7. Terminal arrangement	20
8. Lower row terminals	20
9. Upper row terminals	22
10. Error message	22
11. Maintenance	22
12. Calibration	23

1. Preface

We thank you for your purchase of our Model 461A series. For proper use of this instrument, please read these instructions before the initial operation. Please also take care that this instruction manual is certainly delivered to the person in charge of operation of this instrument.

2. For safety use

Check at delivery

When the model 461A is delivered,

- Please check whether it conforms to the required specifications and has not been damaged in transit. The instrument is carefully tested before the delivery from factory under our strict quality control program, but if any defect or inconvenience in quality or specifications is found, please inform us of the model name and serial number.
- Unpack the instrument and confirm that the followings are included.
(1) Instrument main unit, (2) Stickers of units, (3) Instruction manual.

Cautions for use

For safety in use of the instrument, please observe the following cautions.

• CAUTION
<p>No power on/off switch is provided on the Model 461A, so it immediately starts to work when connected to the power source. The specified data are defined, however, with the pre-heating for 15 minutes.</p> <p>When the Model 461A is mounted into the system cabinet, take care for ventilation so that the temperature inside the cabinet will not exceed 50°C.</p> <p>Do not use the instrument in such places as follows as it may cause break-down or malfunction of the instrument.</p> <p>Places where:</p> <ul style="list-style-type: none"> - exposed to rain, water drops or direct sunlight. - high temperature or humidity, much dust or corrosive gas. - affected by external noise, radio waves or static electricity. - vibration or shock is applied or they are big.

3. Initial setting at factory

Unless particularly requested, each function of the FUNCTION switches is set with the set values in the following table at the delivery from factory.

No.	Function	Setting	Display	User's set value
0	Totalizing constant	20	
1	Initial totalizing value	0	
2	Instantaneous value full scale	20000	
3	Instantaneous value offset	0	
4	Instantaneous value sampling rate	3.3 times/sec.	. . .	
5	Decimal point of instantaneous and totalized value	No DP	.	
6	-----	-----	-----	
7	Cut-off	No Cut-off	
8	Totalization-synchronized pulse	50ms, 1/1	
9	RS-232C Note)	9600bps, no parity, 8 bits	
A	Analog output constant	200	
B	Alarm* batch output mode	Alarm output	
C	AL1 value	0	
D	AL2 value	999999	
E	AL3 value	999999	
F	AL4 value	999999	

Other functions

Function	Setting	Display	User's set value
Change-over of pause/latch	Pause function	
With or without blinking at over-range of totalized value	Without blinking	
Change-over of totalizer reset function	OFF	

Note) FUNCTION switch 9 shows that the totalizer is with RS-232C output.

4. Standard specifications

4.1 Model designation

461A- - - - -
 1 2 3 4 5 6 7

1 Measuring input

Model Name	Measuring Range	Input Resistance	Overload
461A-01	DC0~10mV	1MΩ or more	DC±250V
461A-02	DC0~100mV	1MΩ or more	DC±250V
461A-03	DC0~1V	1MΩ or more	DC±250V
461A-04	DC0~5V	1MΩ or more	DC±250V
461A-05	DC0~10V	1MΩ or more	DC±250V
461A-09	DC1~5V	Approx. 1MΩ	DC±250V
461A-23	DC0~1mA	100Ω	DC±50mA
461A-29	DC4~20mA	Approx. 12.4Ω	DC±150mA

2 Power source voltage

Code	Power Source Voltage
A	AC90~264V 50/60Hz
9	DC24V±10%

3 Power source for sensor

No.	Power Source Voltage	Output Current	Ripple
Blank	Not available		
3	12V±5%	150mA	5% or less
5	24V±5%	50mA	5% or less

4 Analog output Optional specifications

No.	Analog Output	Output Impedance	Tolerable Resistive Load
Blank	Not available		
03	Instantaneous value output	DC0~1V	200Ω or more
04		DC0~5V	1kΩ or more
05		DC0~10V	2kΩ or more
09		DC1~5V	1kΩ or more
29		DC4~20mA	0~600Ω
03T	Totalized value output	DC0~1V	200Ω or more
04T		DC0~5V	1kΩ or more
05T		DC0~10V	2kΩ or more
09T		DC1~5V	1kΩ or more
29T		DC4~20mA	0~600Ω

5 BCD output, RS-232C output, RS-485 output Optional specifications

Refer to the respective instruction manual of BCD output, RS-232C output and RS-485 output.

6 Preset output Optional specifications

Code	Content
Blank	No preset output
R	Instantaneous : H·L Totalizing : With change-over of H·HH or 2 batch steps setting

7 Display colour

Code	Colour
Blank	Red LED
G	Green LED

4.2 General specifications

Instantaneous value measurement	
Instantaneous value display	0~20000, red or green LED, character height 15mm With zero-suppress function Decimal point display: Front switch setting
Scaling	Scaling display : 20~20000 Front switch setting Offset display : 0~19999 Front switch setting Over-range display : Blinking with 000000
Resolution	1/20000
Sampling rate	3.3 times/sec., 1 time/sec., 0.2 times/sec., selection by front switch
Accuracy	$\pm 0.2\%$ of SPAN at $23^{\circ}\text{C} \pm 5^{\circ}\text{C}$ 45~75%RH
Temperature coefficient	$\pm 200\text{ppm}/^{\circ}\text{C}$
Input type	Single ended, floating input
A/D conversion	V-F conversion system
Totalized value measurement	
Totalized value display	0~999999, red or green LED, character height 15mm With zero-suppress function Decimal point display : Front switch setting Over-range display : When exceeded 999999, the count starts from 0 in blinking. Function to select with or without blinking is provided.
Totalizing constant	Totalizing value per hour at 100% input, front switch setting. 20~999999 (180s/lp~36ms/lp)
Initial totalizing value	0~999999, front switch setting.
Accuracy	$\pm (0.2\% + 1\text{digit})$ of rated value. Rated value: Theoretical totalized value when the 100% input is continuously applied.
Display cycle	Same as the instantaneous sampling rate.
Cut off	0~10%, front switch setting.
Pause/Latch (switchable)	Pause: Hold of display and data output of instantaneous and totalized value. Count of totalizing is temporarily stopped. Latch: Hold of display and data output of instantaneous and totalized value. Count of totalizing is continued. No voltage contact or open collector (NPN) Output capacity : 5V 10mA Minimum pulse width : 10ms
Totalization-synchronized pulse output (P.O.)	Output isolated from input. Output signal : Open collector (NPN) Output capacity : 30V 200mA
Reset	RESET switch inside the front panel or RESET terminals on the rear terminal blocks allow to reset the totalized count (to 0) or to the initial totalizing value. It also clears the incomplete batch of pulses of P.O. output. No voltage contact or open collector (NPN) Output capacity : 5V 10mA Minimum pulse width : 10ms
Solutions for power cut	Totalized value is memorized and retained by EEPROM. No count is made during the electricity failure or power turn-off. Data storage duration about 10 years.
Noise rejection	Normal mode (NMR) 50dB Common mode (CMR) 110dB Power source line penetrating noise 1000V
Withstanding voltage	Power terminal - Case DC2100V for 1 min. Terminals - Case AC1500V for 1 min. Terminals - Power source AC1500V for 1 min. Input - Data output AC500V for 1 min.
Insulation resistance	DC500V, 100M Ω or more
Power source	AC90~264V (50/60Hz) or DC24V $\pm 10\%$
Power consumption	AC power source ... approx. 16VA, DC power source ... approx. 300mA
Operating ambient temp.	0~50 $^{\circ}\text{C}$
Storage temperature	-20~70 $^{\circ}\text{C}$
Weight	approx. 500g
Mounting	Fastening with metal brackets from the rear of the panel.

Stickers of units (attached):

m^3/s , m^3/min , m^3/h , Nm^3/s , Nm^3/min , Nm^3/h , l/s , l/min , l/h , kl/min , Nl/min , Nl/h , W/h , kW/h , kg/s , kg/min , kg/h , t/s , t/min , t/h , g/h , m/s , A , m^3 , Nm^3 , l , kl , Nl , Nkl , W , kW , $\text{W} \cdot \text{s}$, $\text{W} \cdot \text{h}$, $\text{kW} \cdot \text{h}$, cal , kcal , Mcal , Gcal , T , t , kg , g , m , km , $\text{A} \cdot \text{h}$, Pa , kPa , MPa , $\text{kA} \cdot \text{h}$, N/m^2 , bar

Note: Actual characters of the stickers may be different from the above printings.

4.3 Dimensions

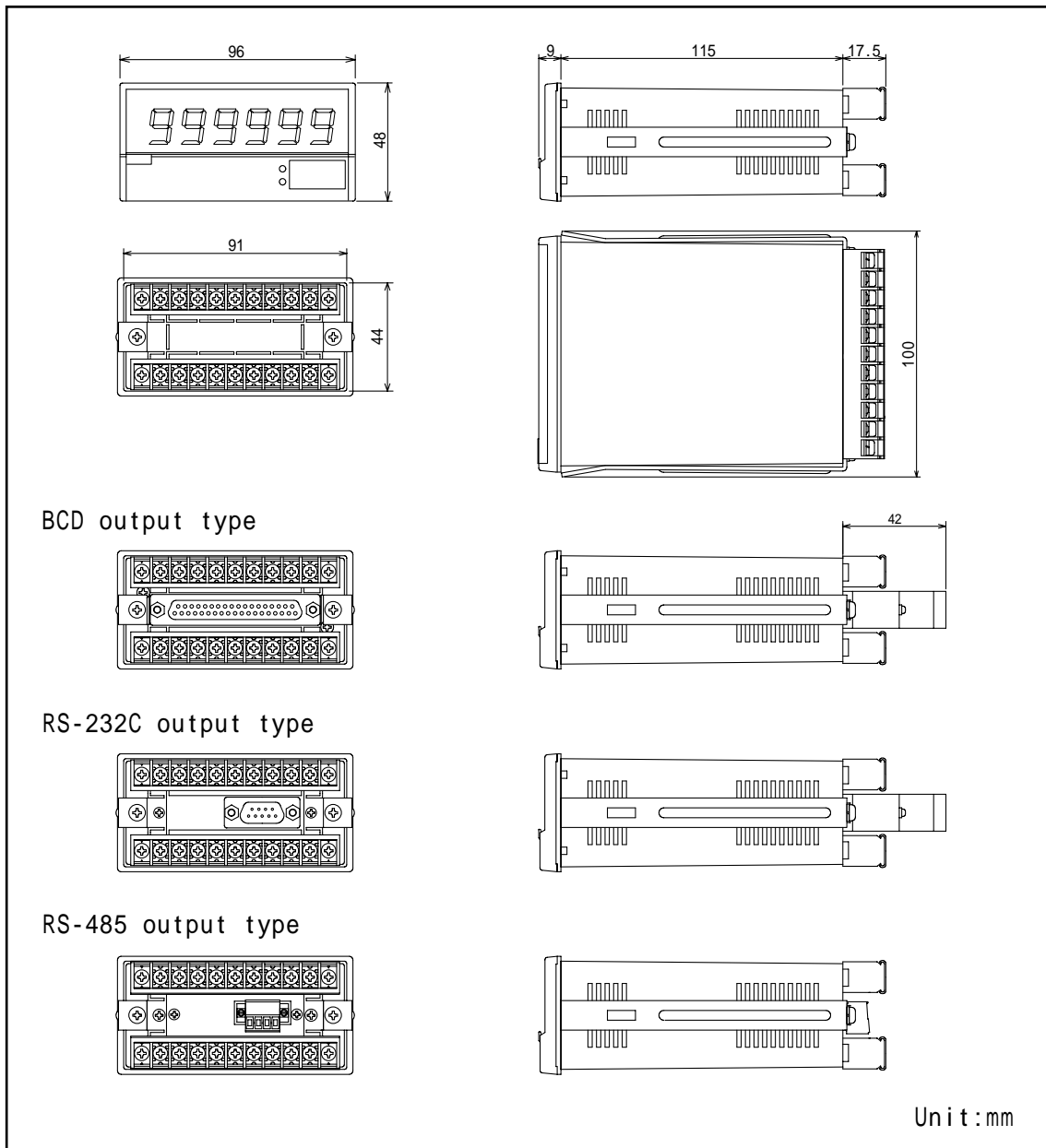

5. Installation

Remove the metal brackets at the both sides, insert the instrument from the front, and fix it with the brackets

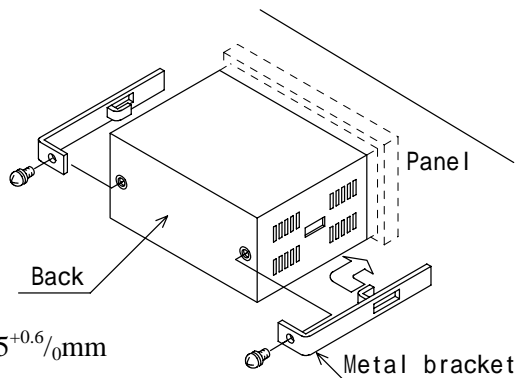

Panel cut-out dimension : $92^{+0.8/0} \times 45^{+0.6/0}$ mm
 Applicable panel thickness : 0.6~6mm
 Optimum fastening torque : 0.25~0.39N·m

· CAUTION

Do not fasten the screws too tight as it may cause a deformation of the case.

6. Setting of each function

6.1 Name of parts

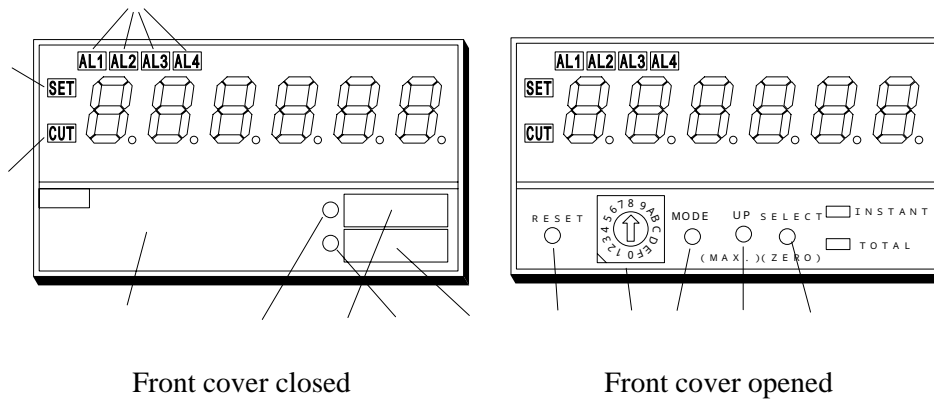

Front cover closed

Front cover opened

Name	Function
Alarm channel display	Monitor of alarm output.
SET display	Lit up in setting mode.
CUT display	Lit up when cut off is set.
Instantaneous value display	Lit up when the instantaneous value is displayed.
Instantaneous value unit	Place to apply a sticker of unit for the instantaneous value.
Totalizing display	Lit up when the totalized value is displayed.
Totalized value unit	Place to apply a sticker of unit for the totalized value.
RESET switch	Switch to reset (to 0) the totalized value.
FUNCTION switch	Selection switch of each setting mode.
MODE switch	Switch to select the measuring or setting mode.
UP switch	Numeral adjustment switch in setting mode.
SELECT switch	Switch to select the instantaneous or totalized value display. Switch to change a set in setting mode.
Front cover	Pull-open front cover.

6.2 Function of setting switches

Number	Functions (parameter to set)	Item No.
0	Totalizing constant	6.6
1	Initial totalizing value	6.7
	*Change-over of pause/latch	6.3.1
2	Full scale of instantaneous value	6.8
	*With or without blinking at over-range of totalized value	6.3.2
3	Offset of instantaneous value	6.9
	*Change-over of totalizer reset function	6.3.3
4	Sampling rate of instantaneous value (3.3, 1 or 0.2 times/sec.)	6.10
5	Decimal point for instantaneous and totalizing value	6.11
6	-----	
7	Cut off	6.12
8	Pulse synchronized with totalizing	6.13
9	RS-232C output, RS-485 output	Note 2
A	Analog output constant (in case of totalized value output type)	Note 3
B	Change-over of totalizing alarm or batch output mode	Note 4
C	AL1 - low limit of instantaneous alarm	Note 4
D	AL2 - High limit of instantaneous alarm	Note 4
E	AL3 - High limit of totalizing alarm or pre-warning batch output	Note 4
F	AL4 - Higher high limit of totalizing alarm or stop batch output	Note 4

* The function is allocated when the power supply is turned ON, simultaneously pressing the **MODE** switch.

Note 1: Function switch is ineffective during the setting mode.

Note 2: Function switch 9 is ineffective when the RS-232C or RS-485 are not optionally provided.

Note 3: Function switch A is ineffective when the analog output is not and instantaneous value optionally provided.

Note 4: Functions switches B, C, D, E, F are ineffective when the alarm output is not optionally provided.

Note 5: When no key is pressed for 5 minutes or more in setting mode, the unit returns to the measuring mode.

6.3 Function and change method

6.3.1 Change-over of pause (temporary stop input) / Latch function

No voltage contact or open collector (NPN)

Contact capacity : 5V 10mA (ON voltage 1.5V or less)

Input pulse width : 10ms or more

Pause function : When making a short-circuit between PA/LA and D.COM terminals on the rear panel, display and BCD data of instantaneous and totalized value are held, and the totalizing count is paused. Analog output is also held.

Latch function : When making a short-circuit between PA/LA and D.COM terminals on the rear panel, display and BCD data of instantaneous and totalized value are held, but the totalizing count is continued. Analog output is held.

How to change:

Set FUNCTION switch to 1, keep pressing MODE switch, turn the power ON.

SET display enters the state of blinking.

Change with UP switch.

PAUSE : PAUSE function

LATCH : LATCH function

Turn the power OFF.

(Note) Totalization-synchronized pulse (P.O.) is retained during the pause is functioning but not retained during the latch is functioning.

6.3.2 Selection of blinking at over-range of totalized value display

It is possible to select a recommended count from 0, with or without blinking when the totalized value display exceeded 999999.

How to change:

Set FUNCTION switch to 2, keep pressing MODE switch, turn the power ON.

SET display enters the state of blinking.

Change with UP switch.

oF.oFF : Recommence a count from 0 without blinking when the totalized value exceeded 999999.

oF.oF : Recommence a count from 0 with blinking when the totalized value exceeded 999999.

Turn the power OFF.

6.3.3 Change-over of totalizer reset function

When the totalizer reset function is ON, the totalized value is reset to the initial totalizing value.

When the function is OFF, the totalized value is reset to 0.

How to change:

Set FUNCTION switch to 3, keep pressing MODE switch, turn the power ON.

SET display enters the state of blinking.

Change with UP switch.

In 7on : Totalizer reset function ON.

In 7oFF : Totalizer reset function OFF.

Turn the power OFF.

Action when the totalized value is over-ranged

When the totalized value has exceeded 999999, the count is re-started from 0, whichever the totalizer reset function is set, ON/OFF.

Action at the totalized value batch output

When the auto-reset is OFF (ineffective)

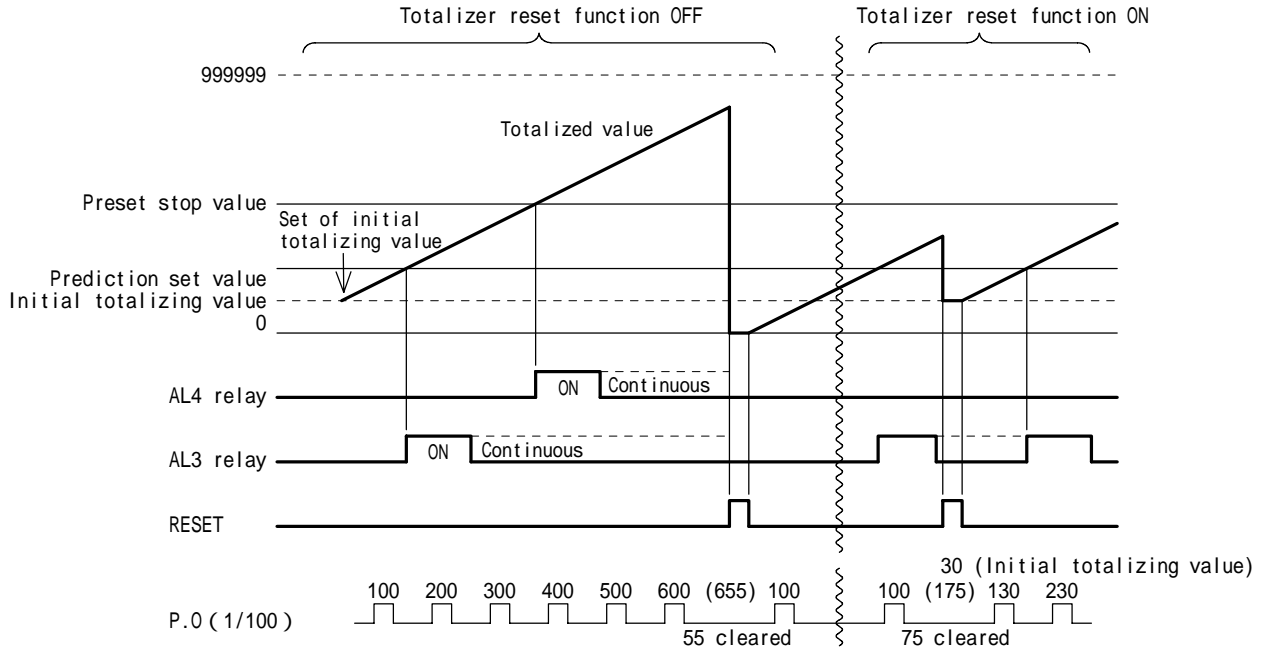

Note-1) When the totalizer reset function is OFF, the totalized value is reset to 0 with reset input, and the incomplete batch of pulses of P.O. output is also cleared.

Note-2) When the totalizer reset function is ON, the totalized value and the incomplete batch of pulses of P.O. output are reset to the initial totalizing value with reset input.

When the auto-reset is ON (effective)

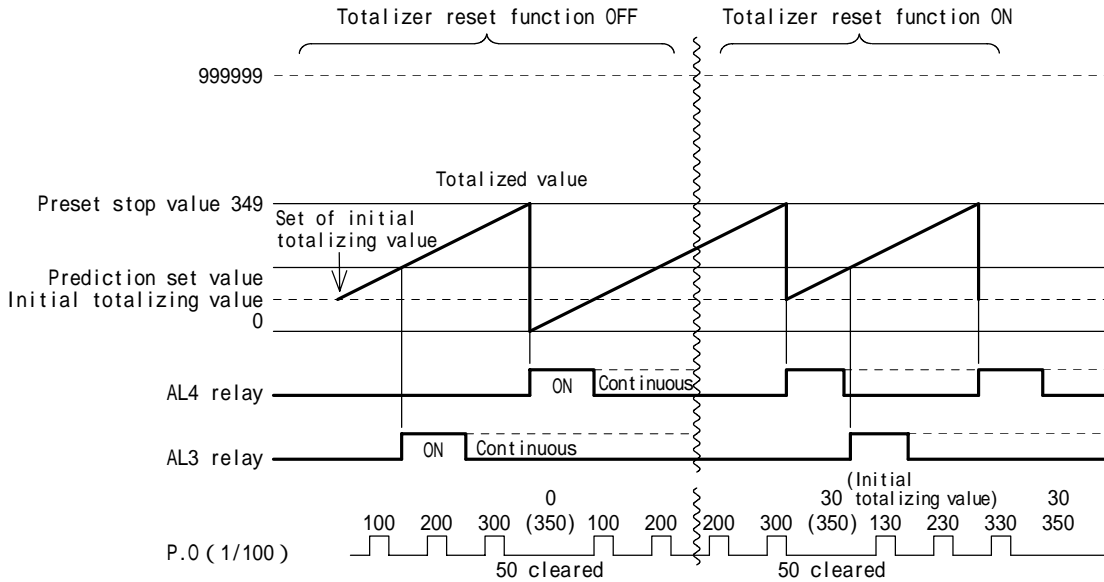

Note-3) When the totalizer reset function is OFF, the totalized value is reset to 0 and the incomplete batch of pulses of P.O. output is cleared when the auto-reset is turned ON.

Note-4) When the totalizer reset function is ON, the totalized value and the incomplete batch of pulses of P.O. output are reset to the initial totalizing value when the auto-reset is turned ON.

Note-5) Adjustable range for the preset stop value: Initial totalizing value < AL4
(If the setting is made out of the range, the display shows Err2.)

6.4 Preset output (AL1~4OUT, ALCOM) Optional specifications

Preset output is the output of instantaneous value alarm (AL1 low limit alarm output, AL2 high limit alarm output) and totalized value alarm (high and higher high limit alarm outputs or two stage batch output).

Contact capacity of output relay : AC250V 0.3A resistive load

(photo MOS relay, “a” contact output, common terminal)

Delay of relay output : Max. 20ms.

1) Instantaneous value alarm output

High and low limit alarm output of instantaneous value (with alarm output monitor on the front panel).

Adjustable range of comparison value is 0~999999 for both high and low alarm output.

The output is synchronized with the display cycle.

Refer to (6.16), (6.17) respectively for the setting of high and low limit.

Conditions for comparison

Instantaneous value > high limit value AL2OUT ON (Front panel monitor AL2 lit up)

Instantaneous value < low limit value AL1OUT ON (Front panel monitor AL1 lit up)

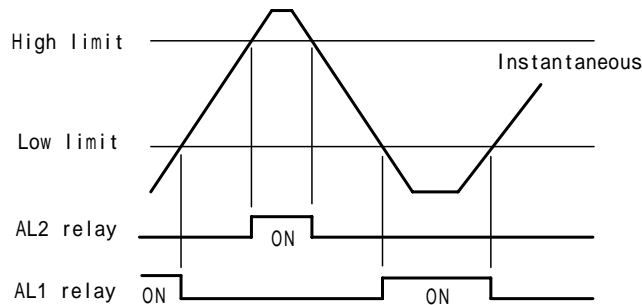

Judgement / Output	AL1OUT-AL.COM	AL2OUT-AL.COM
High limit alarm	OFF	ON
Low limit alarm	ON	OFF

Note: Alarm output is not reset by RESET.

2) Totalized value alarm output

For the totalized value alarm output, high and higher high limit alarm outputs, and two stage batch output are switchable.

Regardless of display, a comparison is made with the counter data one after another.

Refer to (6.15) for the change of mode.

- a) High and higher high limit alarm output (with alarm output monitor on the front panel).
Adjustable range of comparison value is 0~999999 for both high and higher high limit.

Refer to (6.18), (6.19) respectively for the setting method.

Conditions for comparison

Totalized value > high limit AL3OUT ON (Front panel monitor AL3 lit up)

Totalized value > higher high limit AL4OUT ON (Front panel monitor AL4 lit up)

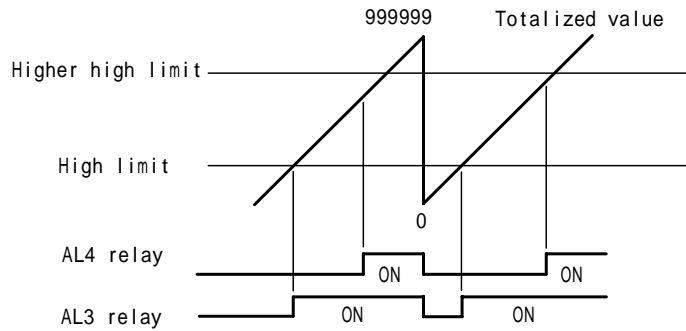

Judgement / Output	AL3OUT-AL.COM	AL4OUT-AL.COM
High limit alarm	ON	OFF
Higher high limit alarm	OFF	ON

b) Totalized value batch output

When the totalized value exceeds the set values at two steps, pre-warning (AL3OUT) and stop (AL4OUT), ON pulse of the relay is output.

Pulse width can be set respectively for pre-warning (T3) and stop (T4).

Stop output is provided with On/Off function for the auto-reset of totalized value.

Pulse width : 0.1 sec., 0.2 sec., 0.5 sec., 1 sec., continuous output.

Note: Continuous output turns OFF with RESET input.

Refer to (6.15) for the selection method.

For the setting of numerals, refer to (6.18), (6.19).

Note: When the mode is changed from the totalized value alarm output to the totalized value batch output, make a reset.

In case that the totalized value is smaller than the pre-warning and stop value, no reset is necessary.

When Auto-reset is OFF

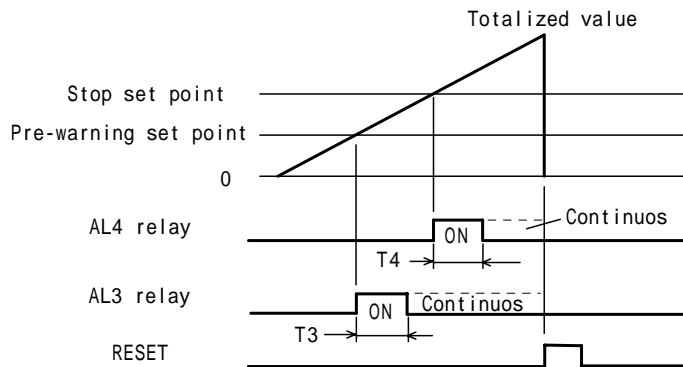

When Auto-reset is ON

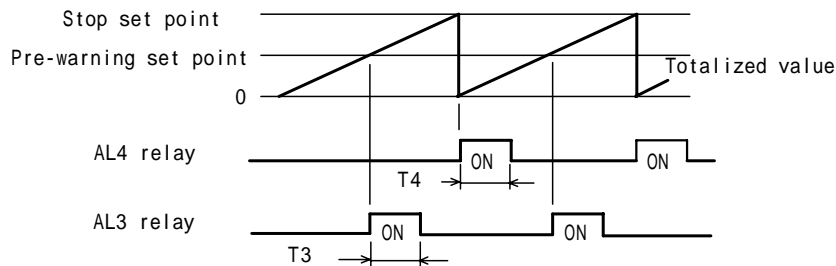

6.5 LED display mode

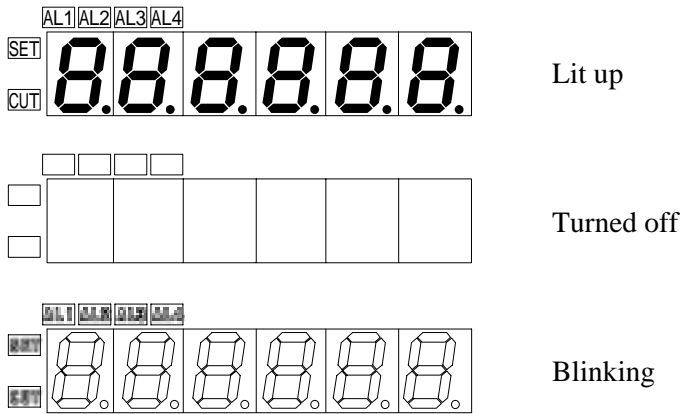

6.6 Totalizing constant.....switch " 0 "

Totalizing constant allows to set the totalized value for 1 hour with 100% input to 20~99999 counts.

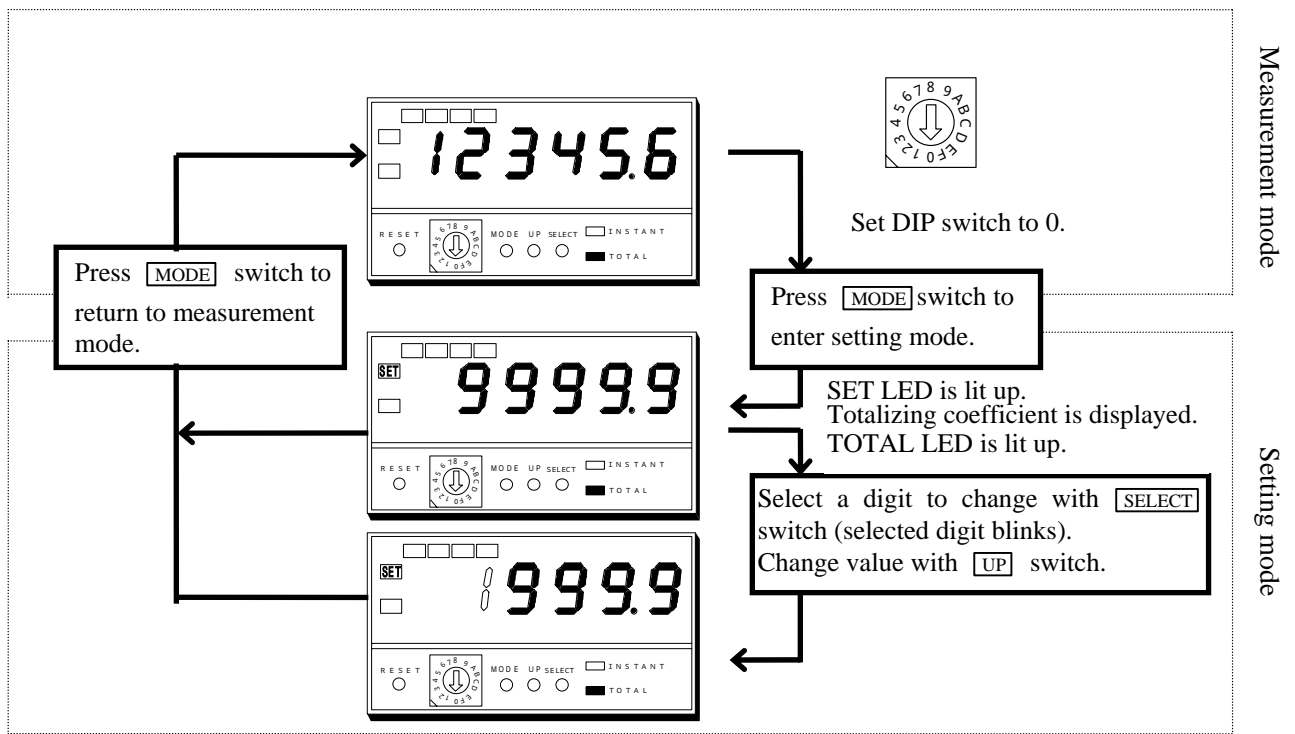

6.7 Initial totalizing value.....switch " 1 "

Initial totalizing value is set when making the count from a halfway.
Adjustable range: 0~999999

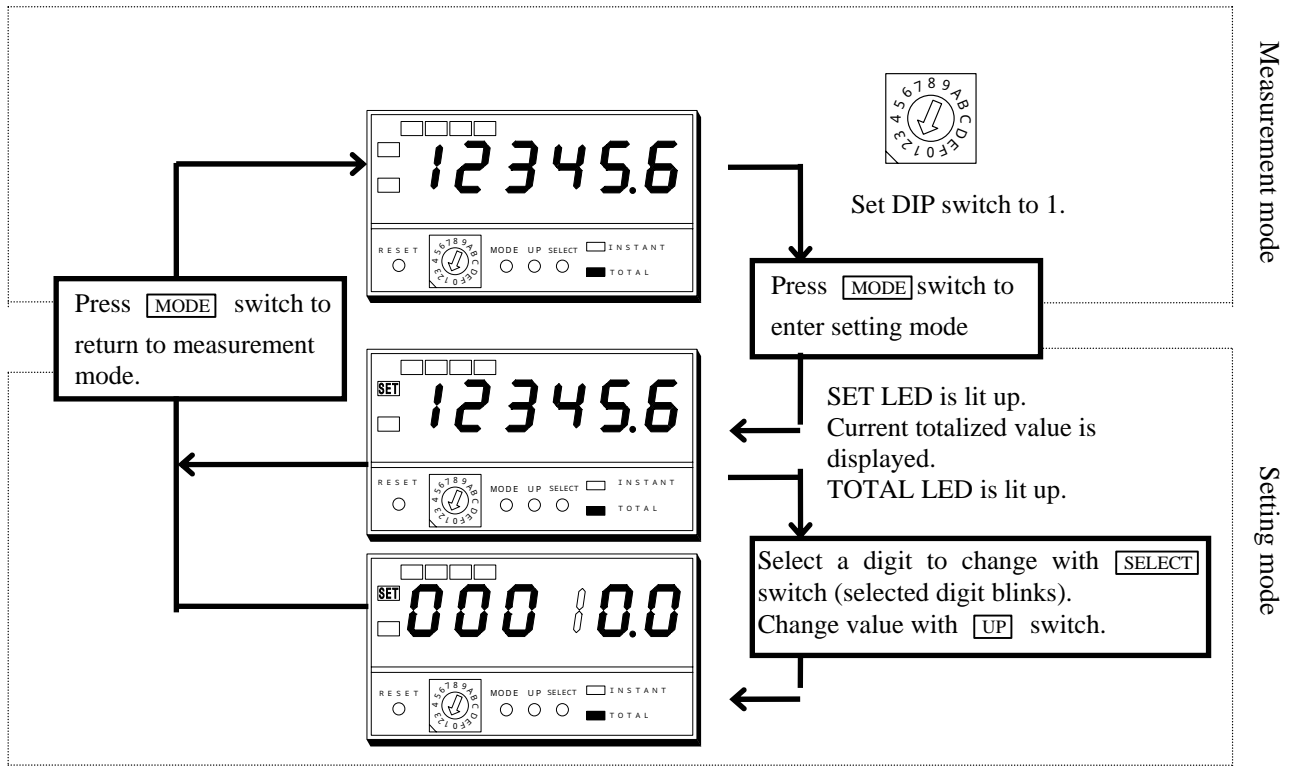

6.8 Instantaneous value measurement full scale.....switch " 2 "

Full scale of instantaneous value measurement can be set to an arbitrary value by the following switch operation.
Adjustable range (100% value of input) : 20~20000

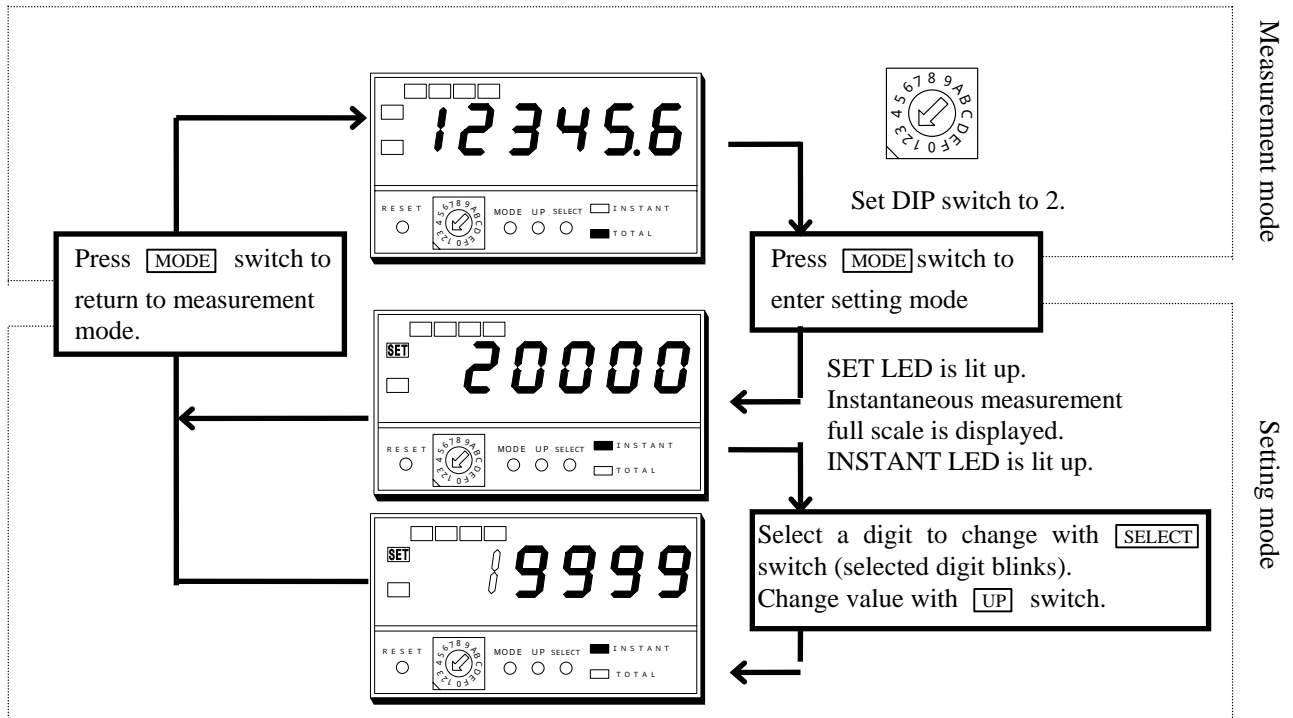

6.9 Instantaneous value offset.....switch " 3 "

Offset of instantaneous value measurement can be set to an arbitrary value by the following switch operation.

Adjustable range (0% value of input) : 0~19999

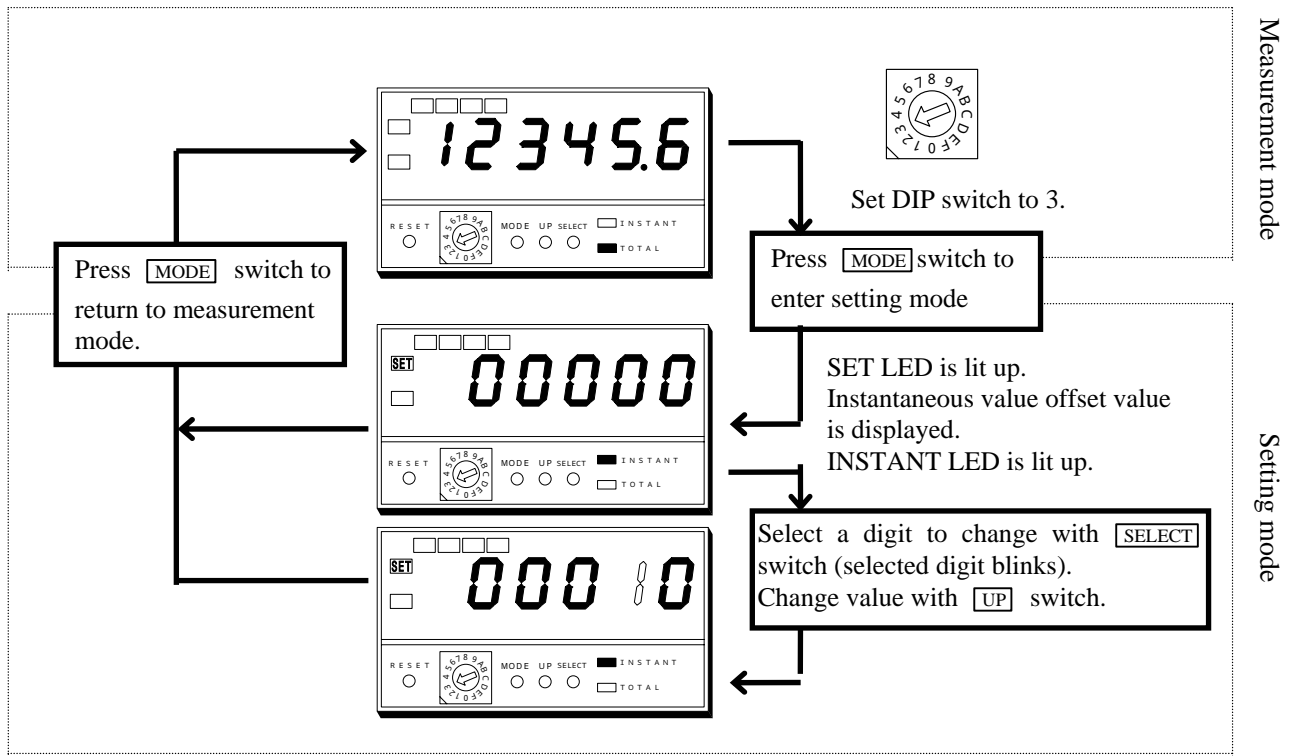

6.10 Instantaneous value measurement sampling rate.....switch " 4 "

Select and set the sampling rate per second, from 3.3 times, 1 time or 0.2 times.

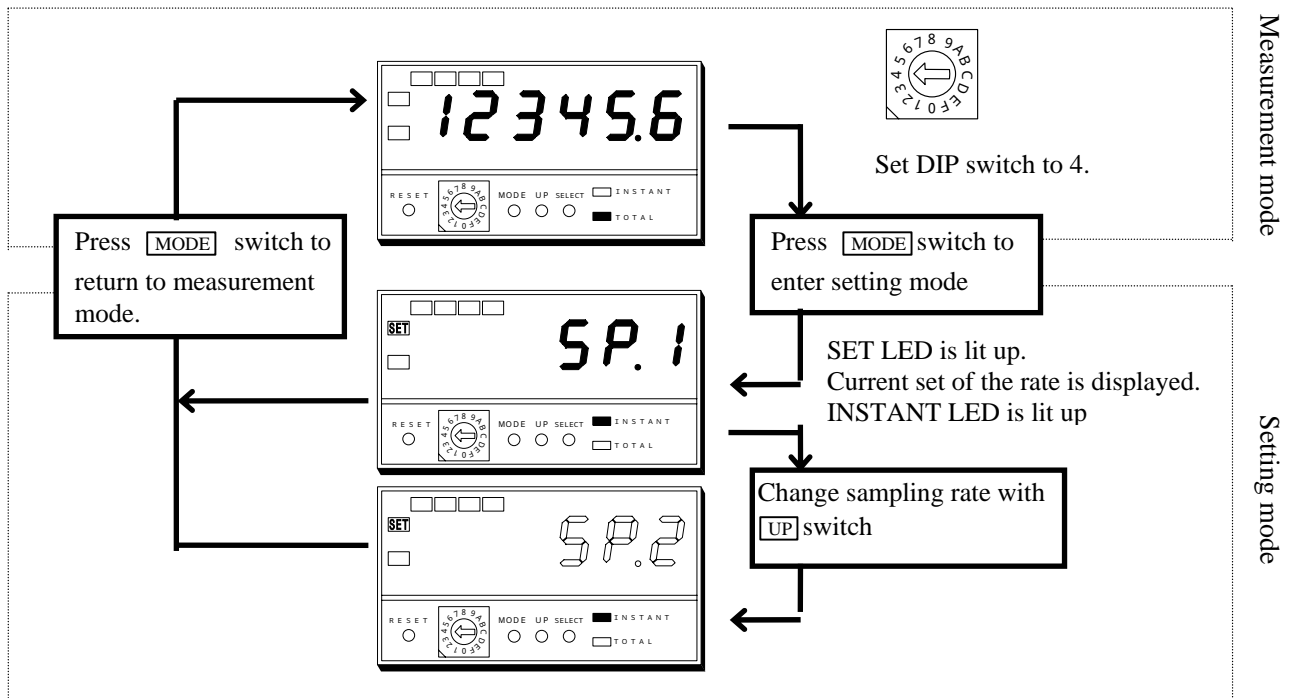

[UP] switch: Changes in the order of SP1 SP2 SP3 SP1.

SP1: 3.3 times/sec. (300ms) SP2: 1 time/sec. (1s) SP3: 0.2 times/sec. (5s)

6.11 Decimal point of instantaneous and totaled value.....switch “ 5 ”

Decimal point position of instantaneous and totaled value can be set by the following switch operation.

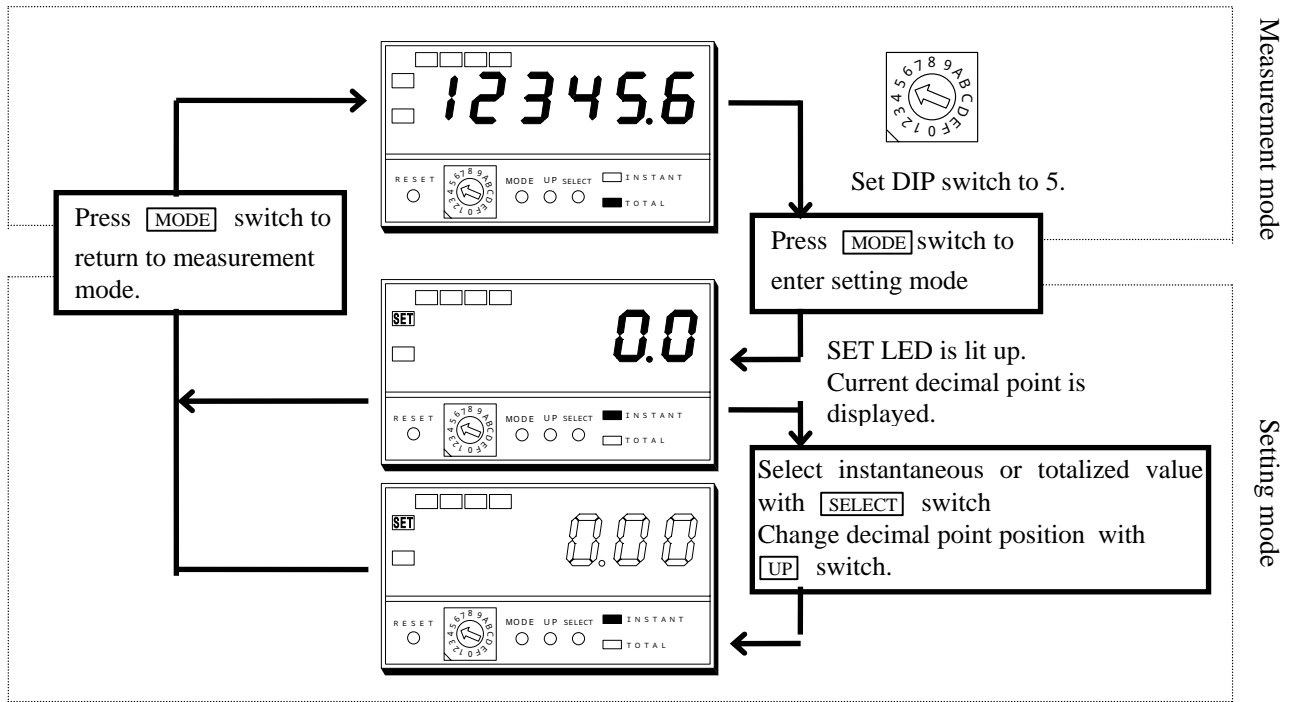

[UP] switch: Changes in the order of NoDP DP1 DP2 DP3 DP4 DP5 NoDP.
 0 : No DP 0.00 : DP2 0.0000 : DP4
 0.0: DP1 0.000: DP3 0.00000: DP5

6.12 Cut-off.....switch “ 7 ”

Input signal in the unstable area of the low level signal can be cut off. In the cut off area, the instantaneous value display is 0 display, and the totalizing count is not made.

When it is functioning, the letters CUT on the front panel is lit up.

Adjustable range: 0~10% (Select from 0, 1, 2, 3, 4, 5, 6, 7, 8, 9, 10)

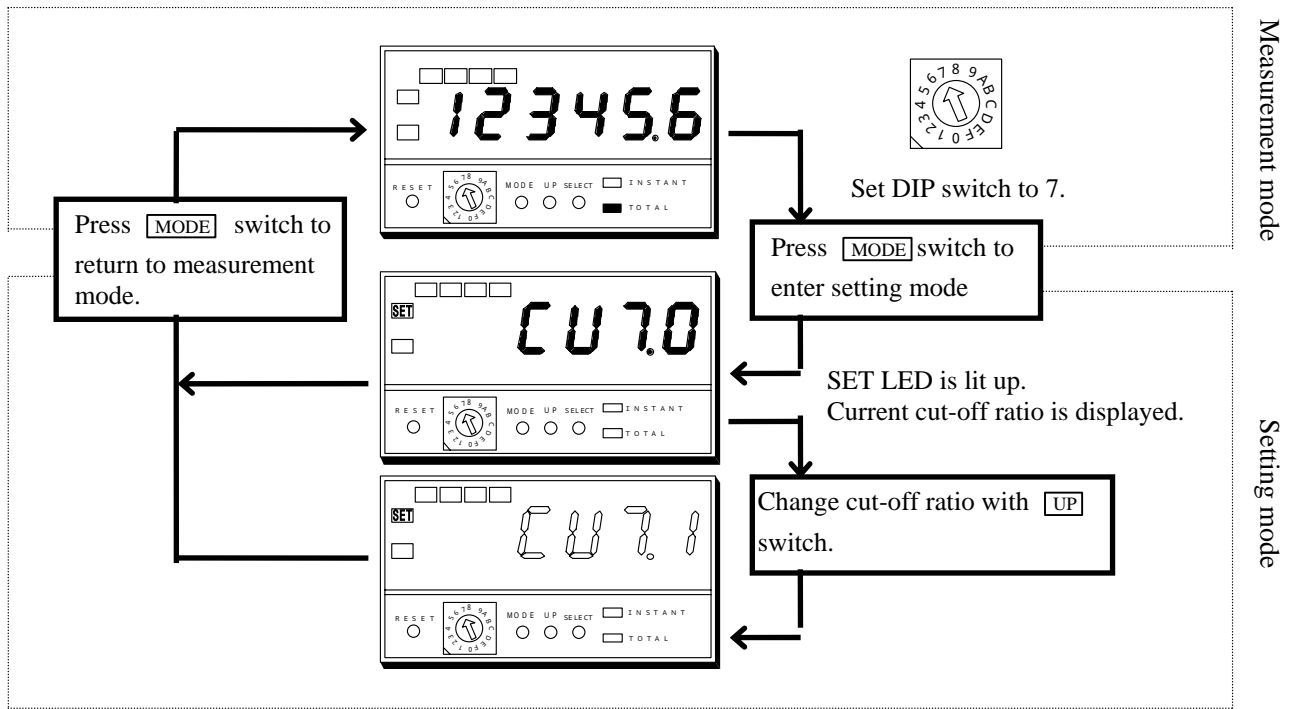

UP switch: Changes in the order of CUT.0 CUT.1 CUT.2 CUT.3 CUT.4 CUT.5
CUT.6 CUT.7 CUT.8 CUT.9 CUT.10 CUT.0.

Setting	Ratio to the input
CUT.0	0% (no cut) CUT turns off
CUT.1	1%
CUT.2	2%
CUT.3	3%
CUT.4	4%
CUT.5	5%
CUT.6	6%
CUT.7	7%
CUT.8	8%
CUT.9	9%
CUT.10	10%

6.13 Totalization-synchronized pulse (P.O)switch " 8 "

Pulse signal which is synchronized with the totalizing count is output.

Output capacity : Open collector output (NPN) DC30V, 200mA

Pulse coefficient : Synchronized pulse output can be set to 1/1, 1/10 or 1/100 of the totalized value by changing the sampling ratio.

Output pulse width : Select a pulse width according to the output frequency.

50ms (when the output frequency is 0Hz~10Hz)

1ms (when the output frequency is 0Hz~30Hz)

50μs (when the output frequency is 0Hz~30Hz)

Note 1: Select the output pulse width so that it will not be wider than the output cycle ($1 / (\text{totalizing constant} \div 3600 \text{ seconds}) \times \text{pulse coefficient}$).
In case that the output cycle is narrower than the output pulse width, the output becomes continuously ON (pulse output is not formed).

Note 2: When the totalizing constant is max. 99999 and the pulse coefficient (ratio) is 1/1, the output frequency is,
 $99999 / 3600 \text{ seconds} \times 1 = 27.78\text{Hz}$.

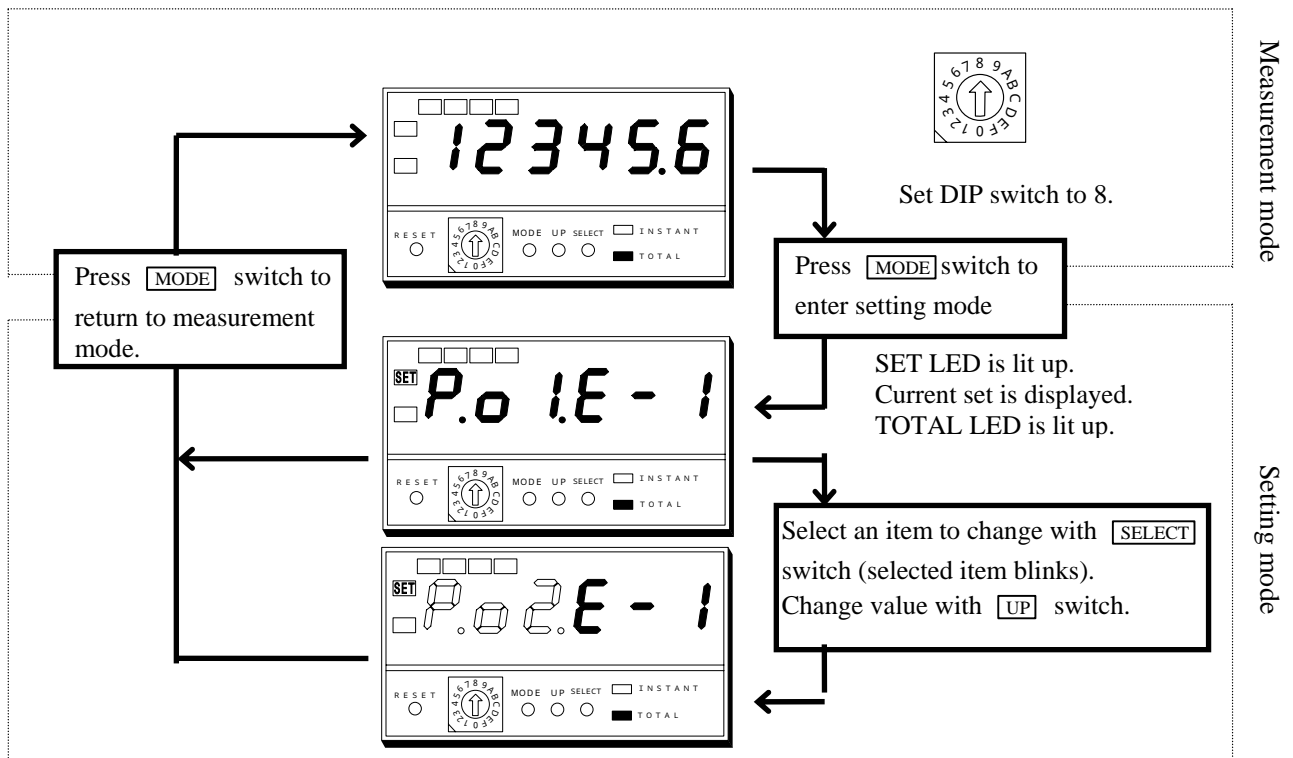
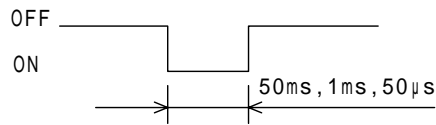

P.o1 E-1

Item 1. Pulse coefficient

Display	Pulse coefficient
E-1	1/1
E-2	1/10
E-3	1/100

UP switch: Changes in the order of E-1 E-2 E-3 E-1

Item 2. Pulse width

Display	Output pulse width
P.o1	50ms
P.o2	1ms
P.o3	50μs

UP switch: Changes in the order of P.o1 P.o2 P.o3 P.o1

6.14 Analog output constant.....switch " A " (Option specifications)

Analog output is isolated from the input and input/output signal.

Instantaneous value output type and totalized value output type output the linear analog data respectively corresponding to the instantaneous input, totalized value.

Analog output constant : 200~999999 (in case of totalized value output type)

When the totalized value reaches the analog output constant value, the analog output gives MAX output.

Accuracy : Instantaneous value analog output type $\pm 0.1\%$ of SPAN ($23^\circ\text{C} \pm 5^\circ\text{C}$)
 Totalized value analog output type $\pm 0.5\%$ of SPAN ($23^\circ\text{C} \pm 5^\circ\text{C}$)

Resolution : 1/2000

Output response : 30ms to instantaneous value or totalized value display.

Note: The output is retained during the PAUSE input or LATCH input.

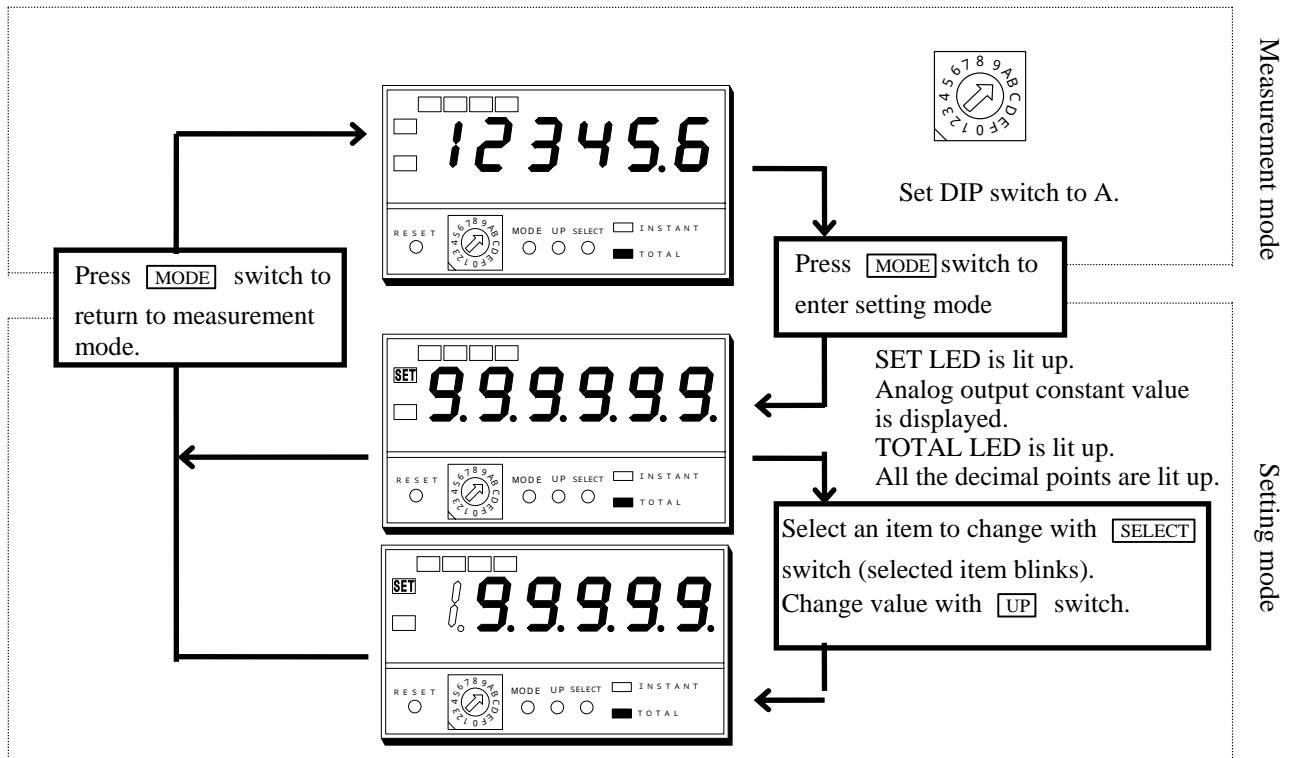

6.15 Change of totalized value alarm output and batch output mode

..... switch " B " (Option specifications)

Change-over of totalized value alarm output and batch output, auto reset ON/OFF and pulse width can be set by the following switch operation.

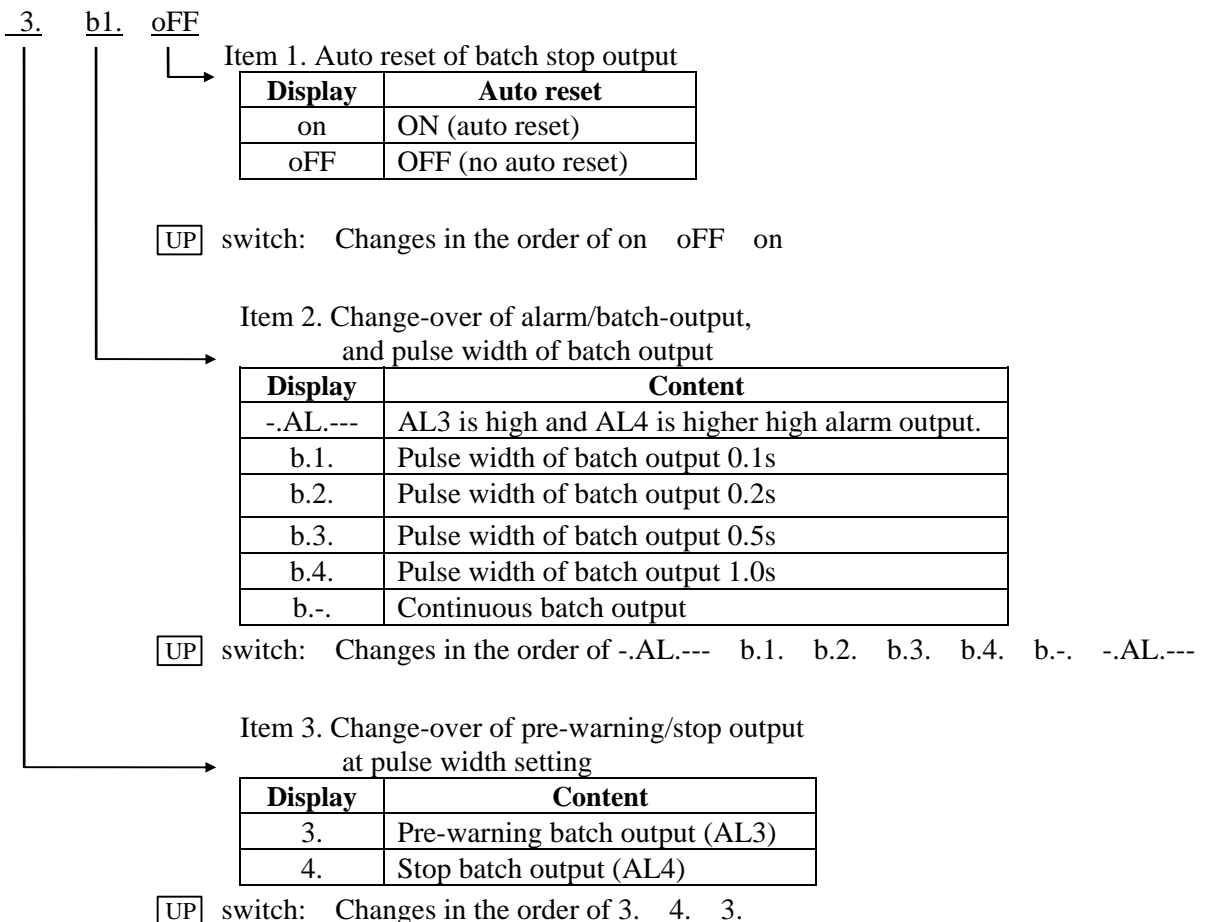
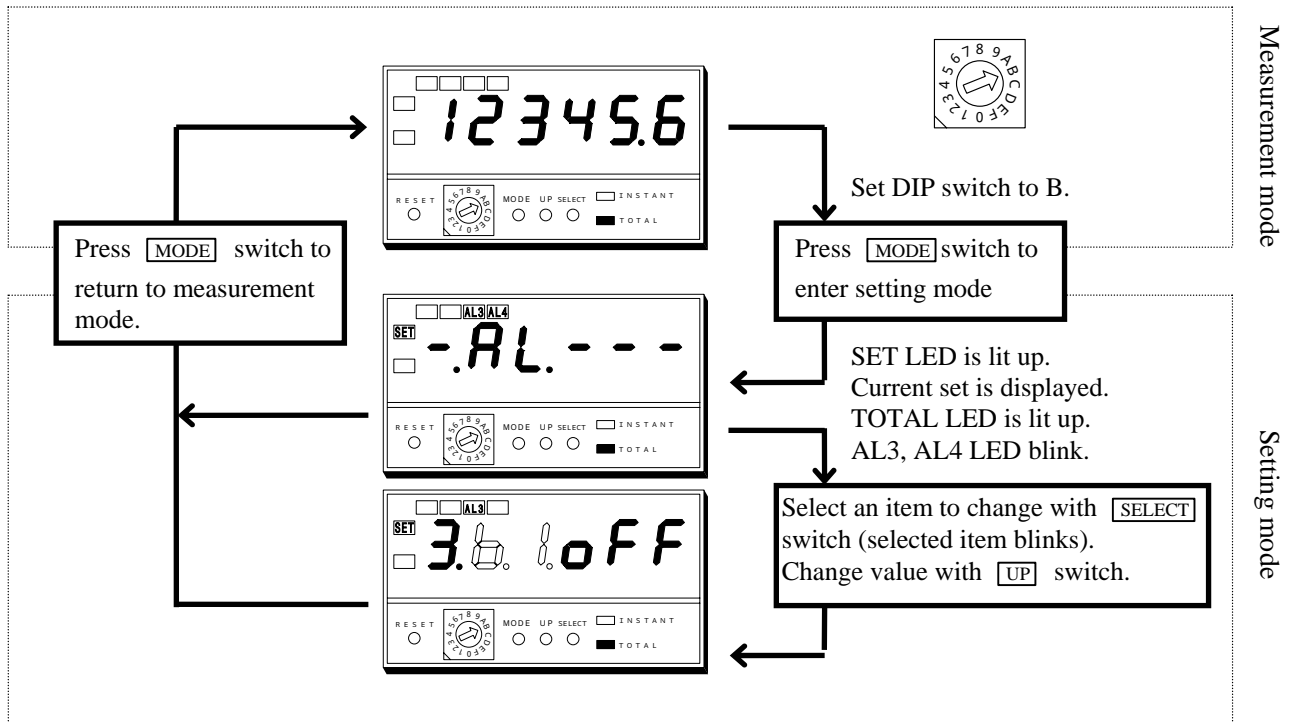

Note: Setting of auto-reset ON/OFF for the stop batch output is possible in both pre-warning and stop mode.

6.16 AL1 Low alarm limit of instantaneous value····switch “ C ” (Option specifications)

Low alarm limit of instantaneous value can be set to an arbitrary value by the following switch operation.

Adjustable range: 0~999999

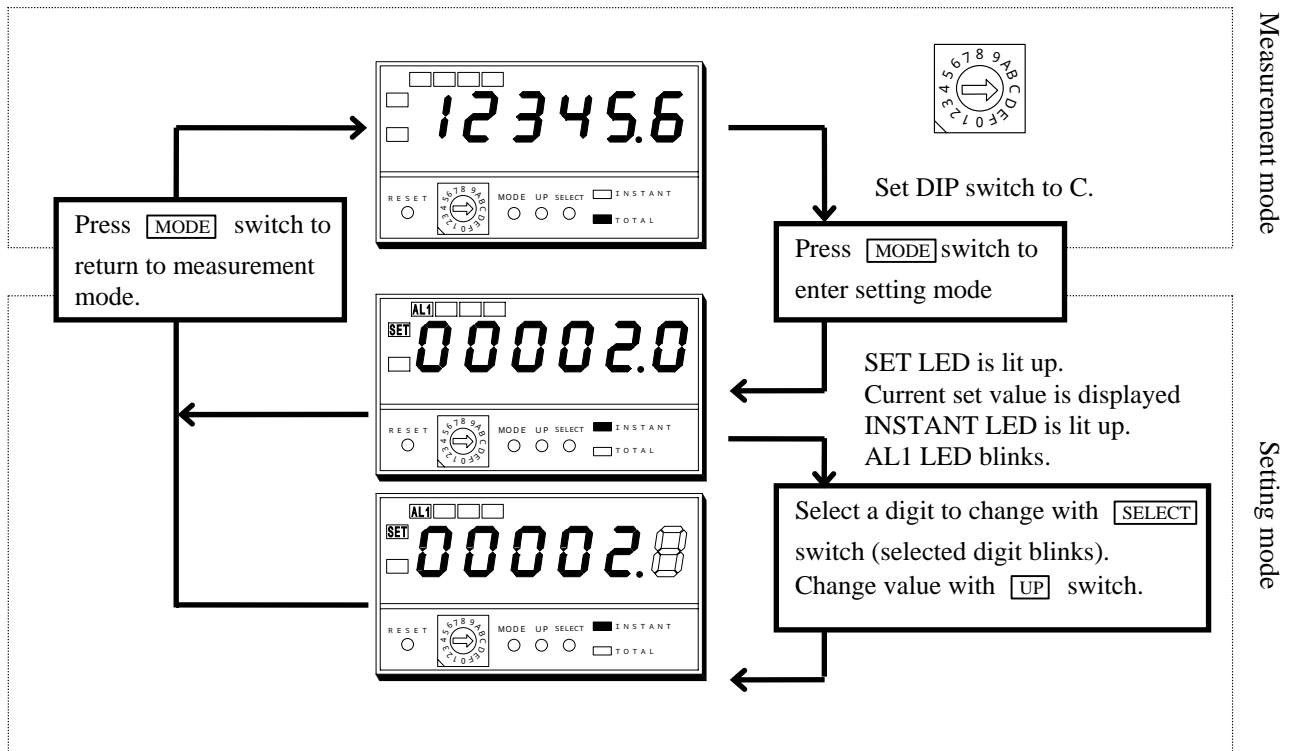

6.17 AL2 High alarm limit of instantaneous value····switch “ D ” (Option specifications)

High alarm limit of instantaneous value can be set to an arbitrary value by the following switch operation.

Adjustable range: 0~999999

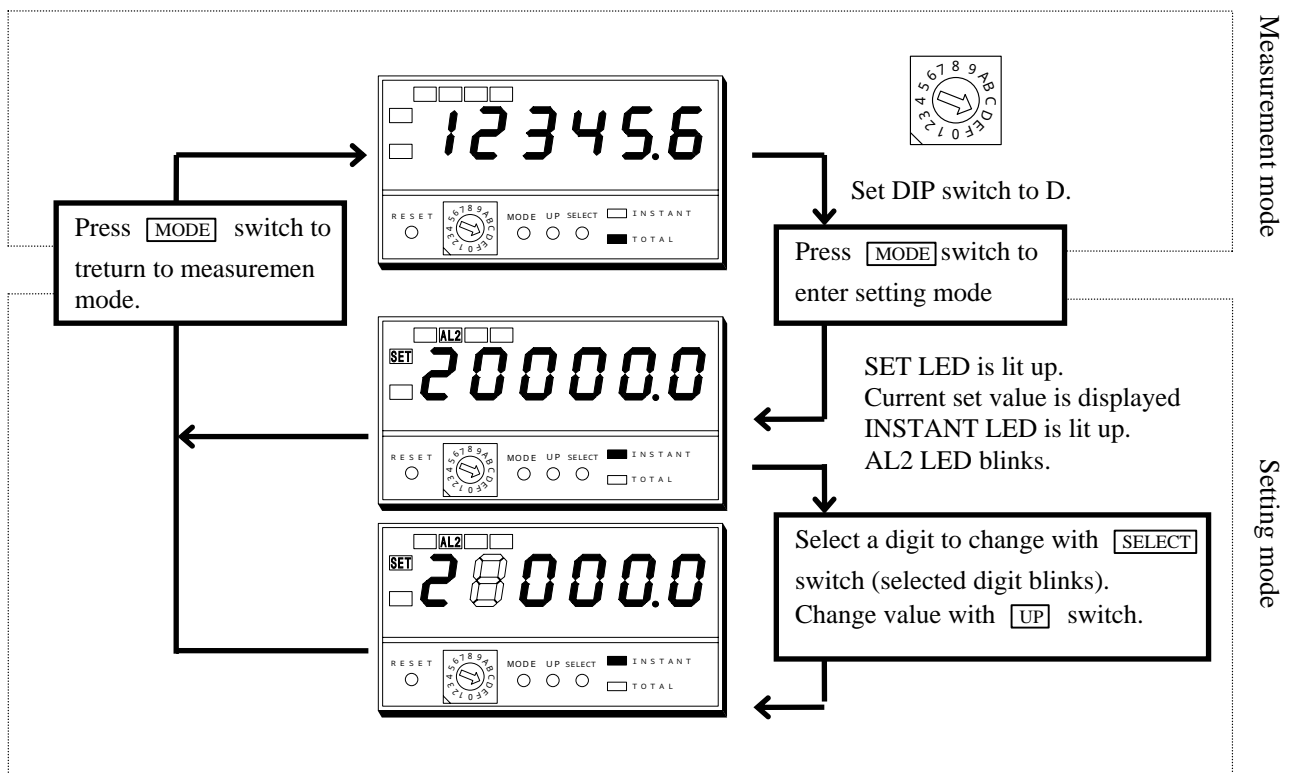

6.18 AL3 High alarm limit of totalized value, or pre-warning batch output
switch " E " (Option specifications)

High alarm limit or pre-warning batch output value of totalized value can be set to an arbitrary value by the following switch operation.
 Adjustable range: 0~999999

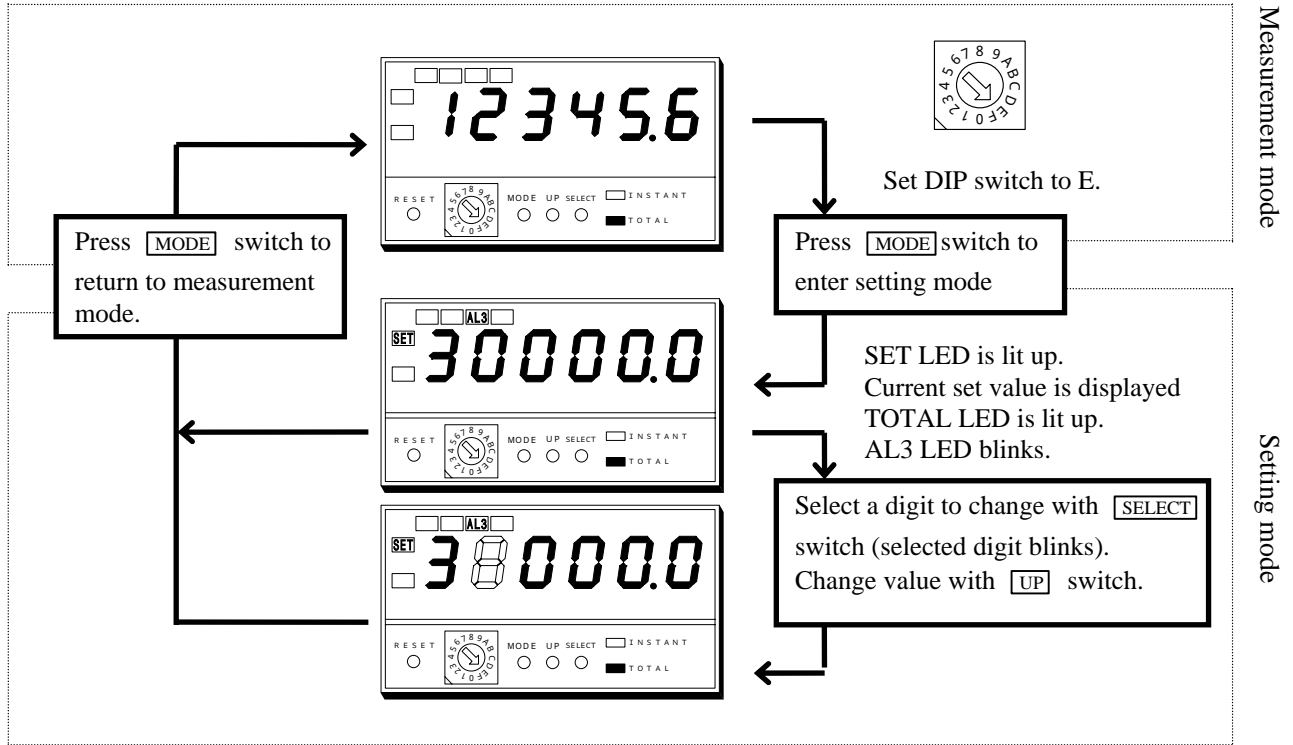

6.19 AL4 Higher High alarm limit of totalized value, or stop batch output
switch " F " (Option specifications)

Higher high alarm limit or stop batch output value of totalized value can be set to an arbitrary value by the following switch operation.
 Adjustable range: 0~999999

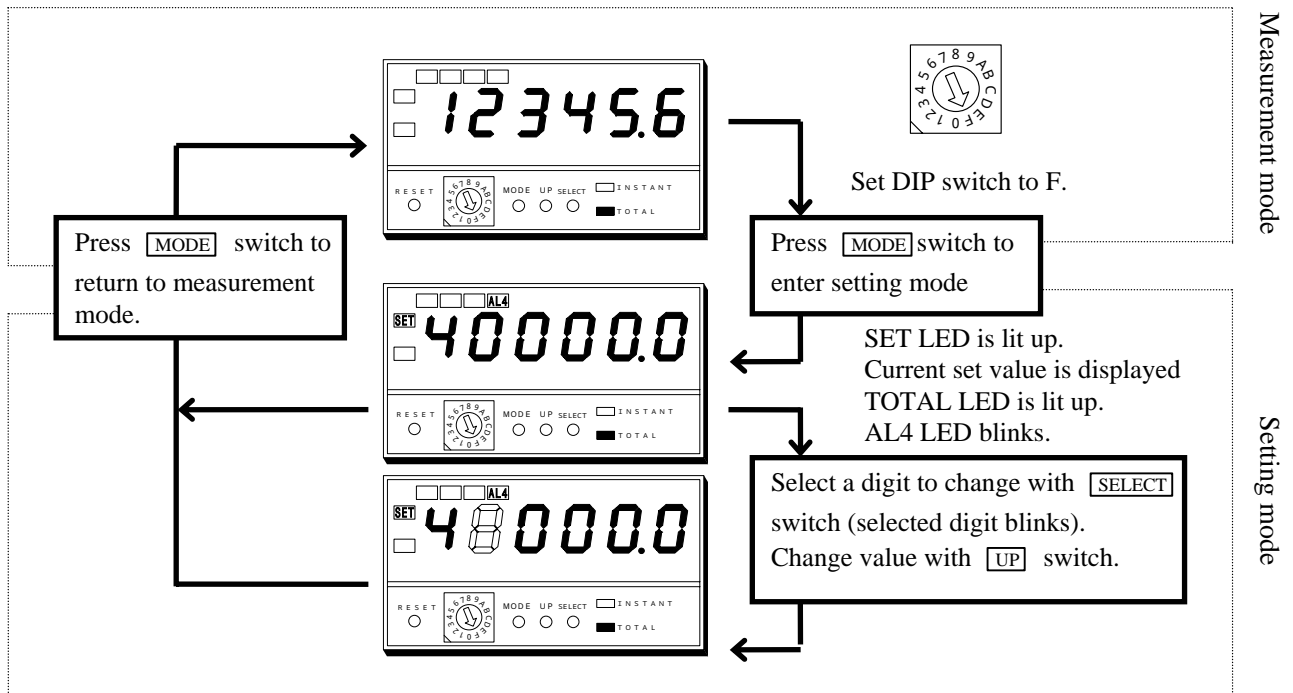

7. Terminal arrangement

Upper row

(without preset output)

Terminal	NC	NC	NC	NC	NC	P.O	RESET	PA/LA	D.COM
	1	2	3	4	5	6	7	8	9
Function	NC					Pulse output	Reset	Pause/Latch	Common

(with preset output)

Terminal	AL1OUT	AL2OUT	AL3OUT	AL4OUT	AL.COM	P.O	RESET	PA/LA	D.COM
	1	2	3	4	5	6	7	8	9
Function	Preset output					Pulse output	Reset	Pause/Latch	Common

Lower row

Note: () at ground and power source terminals are for DC power source types.

(without sensor power source or analog output)

Terminal	Hi	Lo	COM	NC	NC	NC	GND(NC)	P2(+)	P1(-)
	1	2	3	4	5	6	7	8	9
Function	Input		Common	-----			Ground	Power source	

(with sensor power source and analog output)

Terminal	Hi	Lo	COM	SENSOR	A.OUT+	A.OUT-	GND(NC)	P2(+)	P1(-)
	1	2	3	4	5	6	7	8	9
Function	Input		Common	Sensor power	Analog output		Ground	Power source	

Terminal screws : M3

Fastening torque : 0.46~0.62N·m

Crimped terminal : Refer to the figure at the right.

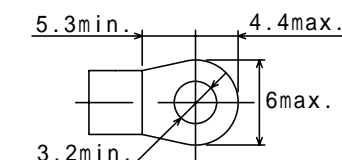

• WARNING

Do not use the meter with wrong wiring as it may cause breakage of the meter.

To avoid an electric shock;

- Turn off the power when the wiring work is done.
- Do not do the wiring work in the humid environment or with the wet hands.
- Do not touch the power source terminals while the meter is powered.

Be careful with the polarity in case of the DC power source types.

Incorrect polarity causes a malfunction of the meter.

8. Lower row terminals

Input (Hi, Lo)

Connect the measurement input with correct polarity.

Connect the line of input with high electric potential to Hi.

Be sure to make a separate wiring for the input line and the power source line. It may cause unstable readings if the wiring of input and power source lines are bundled or close with each other.

Common (COM)

Common terminal for the sensor power source.

Do not use this terminal when the meter is not provided with the power supply to the sensor.

Sensor power source (SENSOR)

Make a connection with correct polarity and without short-circuit. COM terminal is the 0V side.

DC12V built-in type : 12V ± 5% 150mA Ripple 5% or less

DC24V built-in type : 24V ± 5% 50mA Ripple 5% or less

Connection example of sensor power source (+V, 0V)

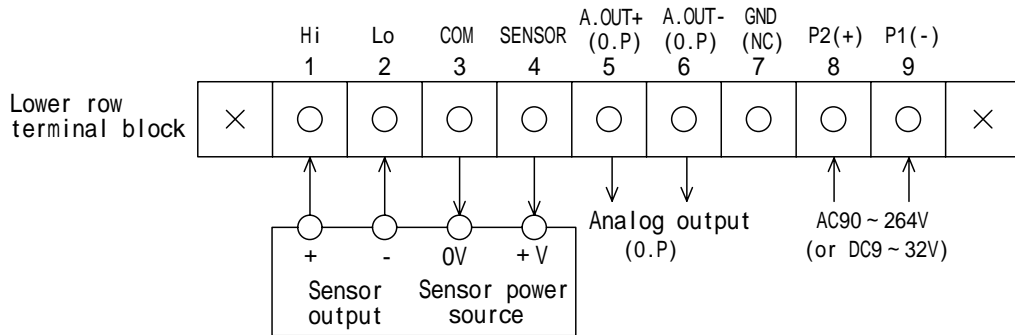

Connection example of 2-wire system transmitter

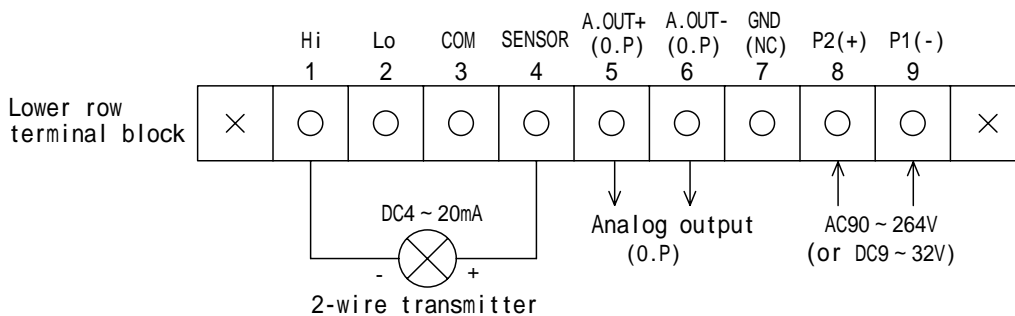

Analog output (A.OUT+, A.OUT-)

Analog signal which is proportional to the instantaneous value (instantaneous value output type) whose full scale is analog output constant value, or the totalized value (totalized value output type) is output.

• CAUTION

Do not apply the voltage externally to the analog output terminals as it may cause breakage of the meter.

NC

NC are the open terminals but do not use these terminals as a relay terminal.

Ground (GND)

In case of fear that the noise is frequently generated on the power source line, it is effective to earth the ground terminal directly to the ground. If the meter is not affected by environmental noise, the earthing can be omitted. In this case, take care that the ground terminal does not touch other terminals, as it is charged with the neutral electric potential of power source voltage.

Supply power source (P1(+), P2(-))

The power source voltage to be supplied is specified on the terminal plate when delivered from factory.

AC power source Use the meter within the range AC90~264V.

DC24V Use the meter with DC24V ± 10%.

Connect +24V of DC power source to P2(+) and 0V side to P1(-).

9. Upper row terminals

Preset output (AL1OUT, AL2OUT, AL3OUT, AL4OUT, AL.COM)

Contact capacity of output relay: AC250V 0.3A resistive load
 (photo MOS relay, “a” contact output, common terminal)
 Delay of relay output Max. 20ms

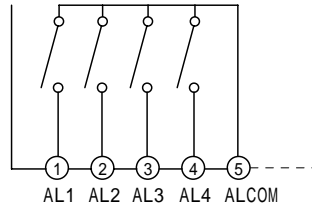

Pulse output (P.O)

Outputs the totalization-synchronized pulse in open collector (NPN).

Reset input (RESET)

Totalized value, totalizing initial value are reset by making a short-circuit between RESET terminal and D.COM terminal.

Pause/latch input (PA/LA)

Short-circuit between PA/LA terminal and D.COM terminal makes pause or latch action.

Data common (D.COM)

COM terminal of P.O, RESET, PA/LA.

10. Error message

When an abnormality occurs during the setting, etc., the following error display appears. Apply the respective remedy.

Display	Cause	Remedy
	When the totalizing constant, full scale of instantaneous value is out of the range.	Press MODE switch and make a setting again.
	When the full scale of instantaneous value is offset of instantaneous value.	Press MODE switch and make a setting again.
	In case of totalizer reset function ON Auto-reset ON at batch output When the relation is initial totalizing value AL4	

11. Maintenance

Store the instrument within the specified temperature range for storage (-20~70°C).

When the front panel or the case becomes dirty, wipe it with soft cloth.

For heavy dirt, wipe it lightly with the soft cloth wetted with the neutral cleaner thinned by water, and finish the cleaning with dry cloth. Do not use organic solvent like benzene or paint thinner as they may deform or discolor the case.

12. Calibration

In order to maintain long term accuracy, periodical maintenance at an interval of about one year is recommended.

Instantaneous value of min. and max. measuring input can be calibrated in the following order.

- (1) ZERO: Input the min. value and calibrate the display to 0.
(calibration range: within $\pm 10\%$)
- (2) MAX: Input the max. value and calibrate the display to 20000
(calibration range: within $\pm 10\%$)

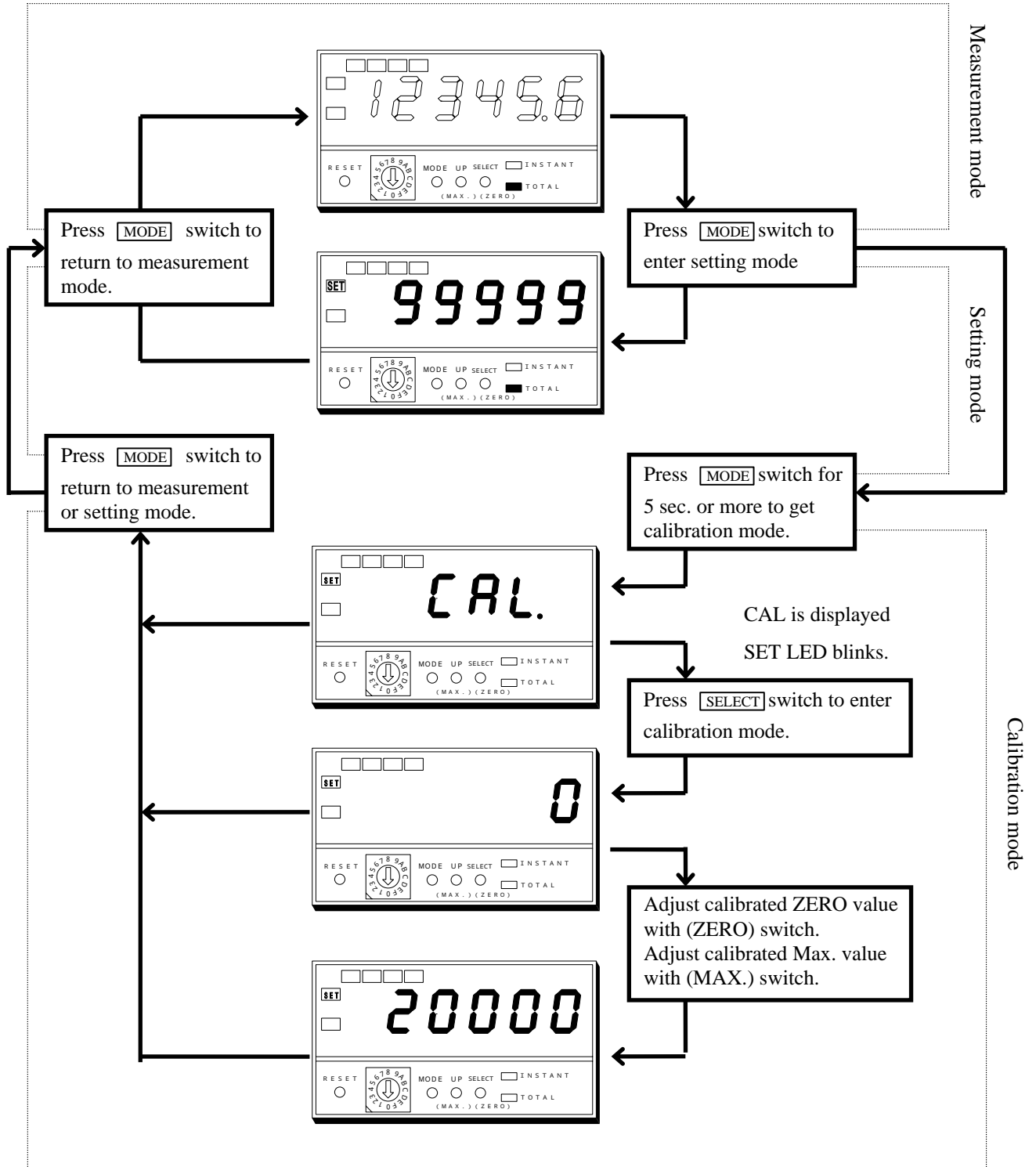

MODEL 461A

- **BCD output**
- **RS-232C output**

Instruction Manual

I-01587

Contents

1. Option specifications	1
1.1 Model designation	1
2. BCD data output	2
2.1 TTL output	2
2.2 Transistor output	3
2.3 Connector arrangement	4
2.4 Timing chart	5
2.5 Connection examples	5
3. RS-232C output	6
3.1 Specifications	6
3.2 Function name and pin number	7
3.3 Output mode	7
3.4 Control, setting mode	8
3.5 Connection	10
4. RS-232C sample program	11

1. Option specification

1.1 Model designation

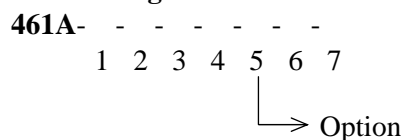

5 BCD output, RS-232C outputt Optional specifications

No.	Specifications
Blank	Not available
BP	BCD output (TTL level, positive logic)
BN	BCD output (TTL level, negative logic)
DP	BCD output (Transistor output, source type)
DN	BCD output (Transistor output, sink type)
E	RS-232C output

2. BCD data output

2.1 TTL output

1) Input and output rates

Name of input & output		TYPE-BP	TYPE-BN	Rate
Output	$\times 10^0 \sim \times 10^5$	Positive logic	Negative logic	TTL level
	DP1, DP2, DP3, DP4, DP5	“L” at output	“H” at output	Fo=2
	OVER	“H” at over	“L” at over	“L”=0~0.8V, “H”=3.5~5V
	SYNC	“L” pulse of 50ms		
Input	LATCH	Latch with short-circuit (“L”)		I _{IL} -1mA “L”=0~0.8V, “H”=3.5~5V
	RESET	Resets counter with short-circuit (“L”)		
	SEL	Totalized value with open (“H”), instantaneous value with short-circuit (“L”)		
	ENABLE	Enabled with open (“H”), prohibited with short-circuit (“L”)		

2) Measurement data output ($\times 10^0 \sim \times 10^5$)

Parallel BCD (1-2-4-8) code, latch output. The output is Tri-state type, so a connection to the data bus is easy.

3) Over-range output (OVER)

The signal is output at the pin [32] when the instantaneous or totalized value is over-ranged.

Note: Over-range of the totalized value is held until reset.

4) Decimal point output (DP1, DP2, DP3, DP4, DP5)

Decimal point of instantaneous or totalized value is output.

5) Synchronized signal output (SYNC)

50ms “L” pulse synchronized with the display cycle is output at the pin [33]. Read a data at the rising point of this SYNC signal. Note: A wired connection is not possible.

6) Data enable input (OUTPUT ENABLE)

When the pin [34] is opened (“H”), a data (including OVER) is output.

When short-circuited (“L”) with the DATA COM ([19] or [37]), the data (including OVER) becomes “high impedance” state. In this state, SYNC output is prohibited and the connection to the data bus is easy.

7) Remote latch input (LATCH)

By short-circuiting the pin [35] and DATA COM ([19] or [37]), or made to “L”, the displayed value and BCD data are held, though the totalizing is continued.

8) Remote reset input (RESET)

Same function as the reset switch inside the front panel. When the pin [36] is short-circuited with DATA COM ([19] or [37]), or made to “L”, the totalized value is reset.

9) Data select input (SEL)

Input to select the BCD output. When the pin [18] is opened (“H”), the totalized value data is output. When short-circuited (“L”) with DATA COM ([19] or [37]), the instantaneous value data is output. The display does not change.

10) Data common (DATA COM)

The pins [19], [37] are the common terminals for the measurement data output, OVER, LATCH, RESET, decimal point output, OUTPUT ENABLE.

Note: Data output and control signal are unified to TTL level, so ensure not to apply the voltage DC5V or higher. Arrange the wiring of data output and control input/output lines apart from the power source line, relays or magnet switches, etc. of big capacity, as well as the input line.

2.2 Transistor output

In case that the BCD output of plural numbers of the instruments are connected to one PC, the wired OR connection of measurement data (including OVER), SYNC is possible.

1) Input and output rates

Name of input & output		Item	TYPE-DP	TYPE-DN
Output	× 10 ⁰ ~ × 10 ⁵ OVER SYNC DP1, DP2, DP3, DP4, DP5	Output type	Source type	Sink type
		Output capacity	DC30V 30mA MAX Saturated voltage 1.6V or less	
Input	LATCH RESET SEL ENABLE	Signal level	Input current = 1mA or less OFF(H)=3.5~5V, ON(L)=0~1.5V	

2) Measurement data output (× 10⁰ ~ × 10⁵)

Parallel BCD (1-2-4-8) code, latch output.

Transistor ON with measurement data “1”. Transistor OFF with measurement data “0”.

3) Over-range output (OVER)

Transistor ON at the pin [32] when the instantaneous or totalized value is over-ranged.

Note: Over-range of the totalized value is held until reset.

4) Decimal point output (DP1, DP2, DP3, DP4, DP5)

Decimal point of instantaneous or totalized value is output.

Transistor OFF with “1”. Transistor ON with “0”.

5) Synchronized signal output (SYNC)

50ms “L” pulse synchronized with the display cycle is output at the pin [33]. Read a data at the rising point (ON OFF) of this SYNC signal.

6) Data enable input (OUTPUT ENABLE)

When the pin [34] is opened (“OFF”), a data (including OVER) is output.

When short-circuited (“ON”) with the DATA COM ([19] or [37]), the data (including OVER), SYNC become “OFF” state, making a connection to the data bus easy.

7) Remote latch input (LATCH)

By short-circuiting the pin [35] and DATA COM ([19] or [37]), the displayed value and BCD data are held, though the totalizing is continued.

8) Remote reset input (RESET)

Same function as the reset switch inside the front panel. When the pin [36] is short-circuited with DATA COM ([19] or [37]), the totalized value is reset.

9) Data select input (SEL)

Input to select the BCD output. When the pin [18] is opened, the totalized value data is output. When short-circuited with DATA COM ([19] or [37]), the instantaneous value data is output. The display does not change.

10) Data common (DATA COM)

The pins [19], [37] are the common terminals for the measurement data output, OVER, LATCH, RESET, decimal point output, OUTPUT ENABLE.

2.3 Connector arrangement

Function		Pin No.		Function	
$\times 10^1$	1	1	20	1	$\times 10^0$
	2	2	21	2	
	4	3	22	4	
	8	4	23	8	
$\times 10^3$	1	5	24	1	$\times 10^2$
	2	6	25	2	
	4	7	26	4	
	8	8	27	8	
$\times 10^5$	1	9	28	1	$\times 10^4$
	2	10	29	2	
	4	11	30	4	
	8	12	31	8	
DP1		13	32	OVER	
DP2		14	33	SYNC	
DP3		15	34	OUTPUT ENABLE	
DP4		16	35	LATCH	
DP5		17	36	RESET	
SEL		18	37	DATA COM	
DATA COM		19			

Connector: (D-sub 37P) XM2A-3701 is attached.

2.4 Timing chart

TTL level output (-BP, -BN)

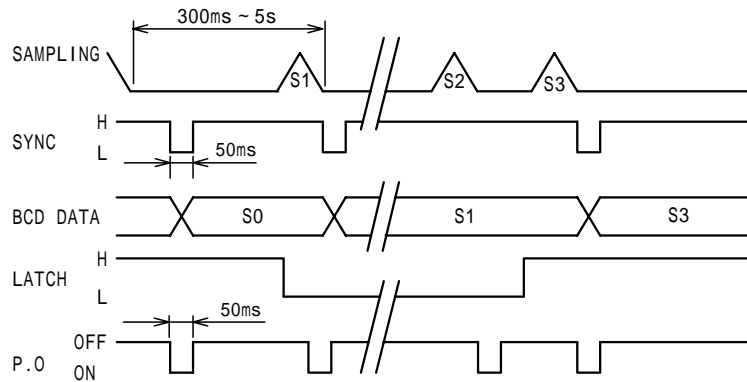

Note 1) P.O is non-synchronized with SYNC.

Transistor output (-DP, -DN)

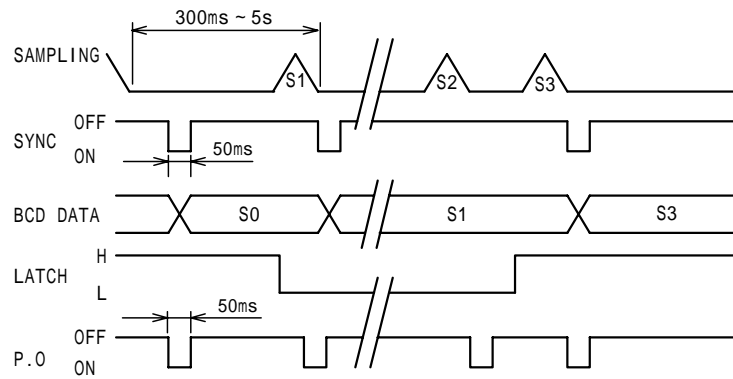

Note 1) P.O is non-synchronized with SYNC.

2.5 Connection examples

Source type

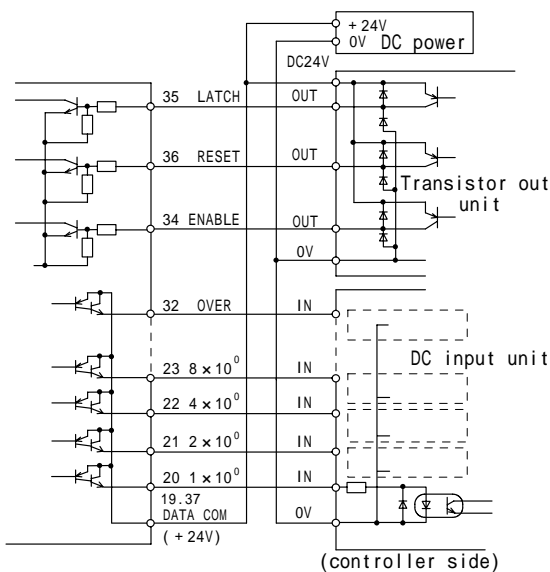

Sink type

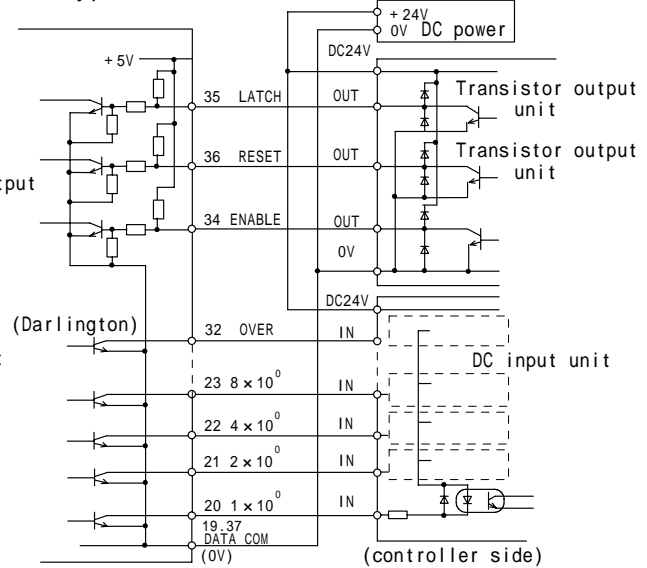

3. RS-232C output

Prior to the communication, make a setting of transmission speed, data bit, parity with the front switch.

3.1 Specifications

- Transmission system : Start-stop synchronous duplex transmission
- Transmission speed : 9600, 4800, 2400 bps
Note: Use the 9600bps with LF range of the input frequency range.
- Data length : 8bit + 1 stop bit, 7bit + 1 stop bit.
- Parity : None, even number, odd number
- Data : Compatible with JIS 8 units code.
- Parameter : ON/OFF provided(DC1, DC3).
- Note: Isolated from the measurement input.

RS-232C output

Transmission speed, data bit and parity can be set by the following switch operation.

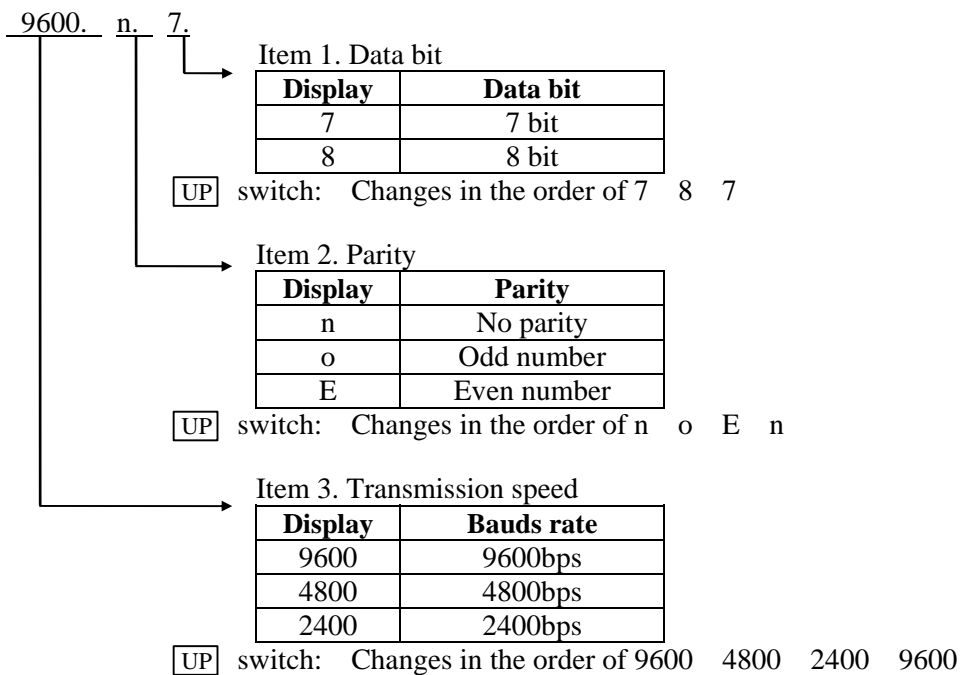
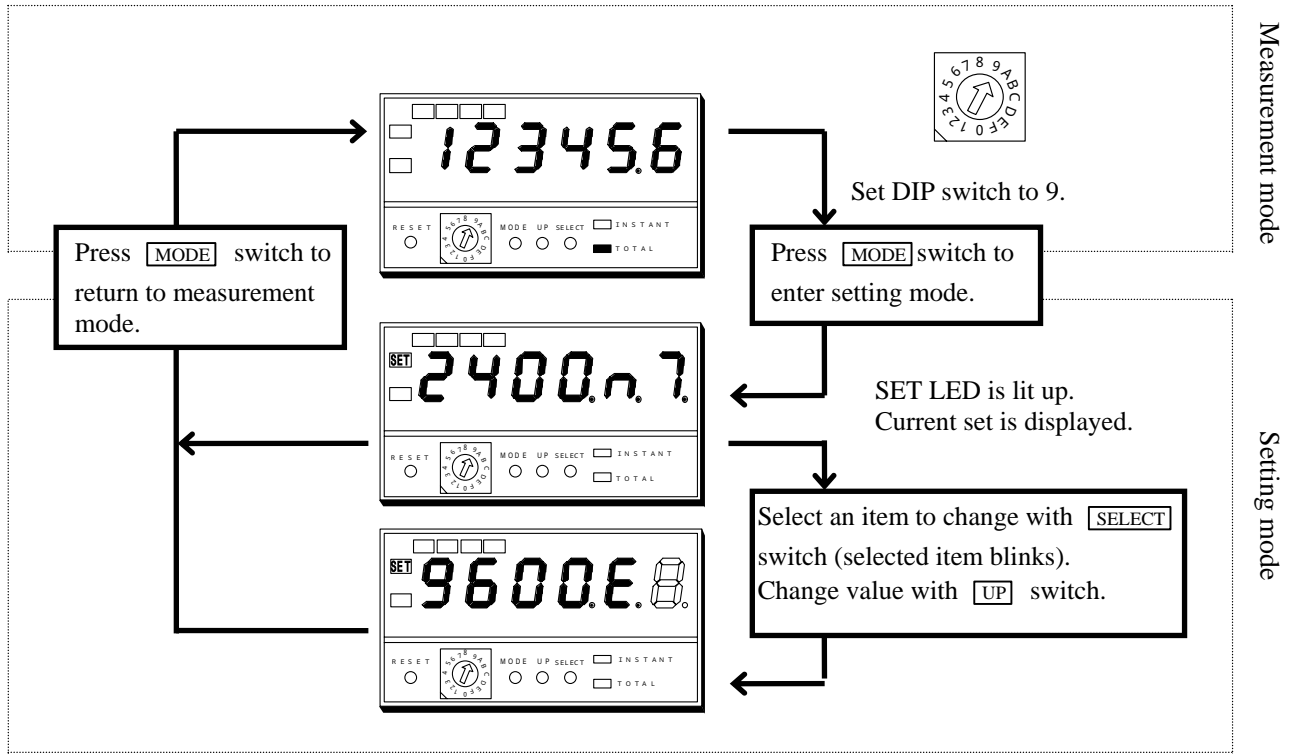

Note: Stop bit is fixed at 1.

3.2 Function name and pin number

Function	Pin No.		Function
NC	1	6	NC
Receiving data (RD)	2	7	Ready to send (RS)
Sending data (SD)	3	8	Clear to send (CS)
Data end ready (ER)	4	9	NC
Signal grounding (SG)	5		

Connector: (D-sub 9P) XM2D-0901 is attached.

3.3 Output mode

Data is output only when it is requested.

1) Read out of measurement data

Control data format

DATA? ·

Measurement data format

When the data is instantaneous value

+0. 19999E+0, AL1AL2 ·

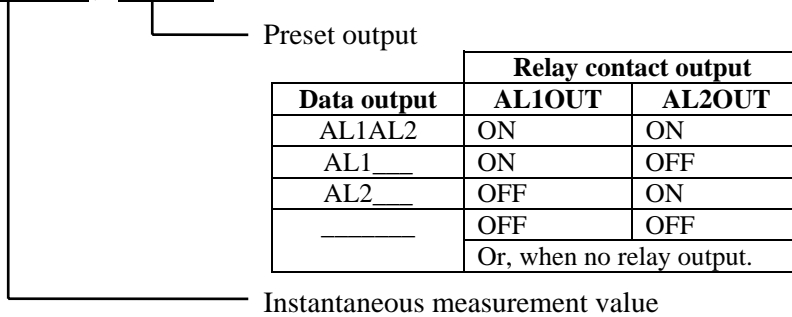

Measurement value:

Decimal point position is indicated by actual numeral article and index article.

Output examples

+0.00000E+5, _____ ·
 +0.00000E+0, _____ ·
 +0.00000E+1, _____ ·
 +0.19999E+2, AL1 ___ ·
 +0.19999E+3, AL1AL2 ·
 +0.19999E+4, AL2 ___ ·
 At over-range
 +OVER _____ ·

Instantaneous value	AL1OUT	AL2OUT
0	OFF	OFF
0.0000	OFF	OFF
0.000	OFF	OFF
199.99	ON	OFF
1999.9	ON	ON
19999	OFF	ON

When the data is totalized value

+1.99999E+0, _____ ·

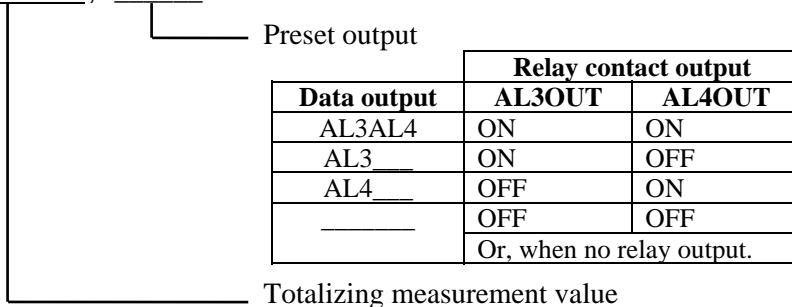

Measurement value:

Decimal point position is indicated by actual numeral article and index article.

Output examples

+0.00000E+5, _____ ·
 +0.00000E+0, _____ ·
 +0.00000E+1, _____ ·
 +1.99999E+2, AL3 ___ ·
 +1.99999E+3, AL3AL4 ·
 +1.99999E+4, AL4 ___ ·
 At over-range
 *1.99999E+0, _____ ·

Totalized value	AL3OUT	AL4OUT
0	OFF	OFF
0.00000	OFF	OFF
0.0000	OFF	OFF
199.999	ON	OFF
1999.99	ON	ON
19999.9	OFF	ON

Note: ___ is space (20H).

3.4 Control, setting mode

Various set values are memorized and held by EE-PROM.

Note: When the various setting are done in sequence, keep an interval of 10 ms between each setting.

- 1) Change of instantaneous and totalized value data output
Control data format
Designation of totalized value data
DATA=TOTAL__ ·
Designation of instantaneous value data
DATA=INSTANT ·
- 2) Designation of totalizing constant setting
Control data format TOTAL=99999 ·
TOTAL=10000 ·
TOTAL=00100 ·
- 3) Designation of initial totalizing value setting
Control data format INITIAL=000100 ·
- 4) Designation of instantaneous pulse conversion value
Control data format FULLSCAL=20000 ·
FULLSCAL=10000 ·
FULLSCAL=00100 ·
- 5) Designation of instantaneous value offset setting
Control data format OFFSET=19999 ·
OFFSET=10000 ·
OFFSET=00100 ·
- 6) Designation of display sampling rate setting
Control data format SAMPLING=3.3 · (3.3 times/sec.)
SAMPLING=1__ · (1 time/sec.)
SAMPLING=0.2 · (0.2 time/sec.)
- 7) Designation of decimal point setting
Instantaneous value
Control data format DPINSTANT=0 · (0)
DPINSTANT=1 · (0.0)
DPINSTANT=2 · (0.00)
DPINSTANT=3 · (0.000)
DPINSTANT=4 · (0.0000)

Totalized value
Control data format DPTOTAL=0 · (0)
DPTOTAL=1 · (0.0)
DPTOTAL=2 · (0.00)
DPTOTAL=3 · (0.000)
DPTOTAL=4 · (0.0000)
DPTOTAL=5 · (0.00000)

8) Designation of cut-off setting

Control data format CUTOFF=0 • (CUTOFF=OFF) CUTOFF=6 • (CUTOFF=6%)
CUTOFF=1 • (CUTOFF=1%) CUTOFF=7 • (CUTOFF=7%)
CUTOFF=2 • (CUTOFF=2%) CUTOFF=8 • (CUTOFF=8%)
CUTOFF=3 • (CUTOFF=3%) CUTOFF=9 • (CUTOFF=9%)
CUTOFF=4 • (CUTOFF=4%) CUTOFF=10 • (CUTOFF=10%)
CUTOFF=5 • (CUTOFF=5%)

9) Designation of totalization-synchronized pulse output setting

Pulse width

Control data format P.OWIDTH=1 • (50ms)
P.OWIDTH=2 • (1ms)
P.OWIDTH=3 • (50μs)

Pulse coefficient

Control data format P.ORATIO=100 • (1/100)
P.ORATIO=10_ • (1/10)
P.ORATIO=1__ • (1/1)

10) Designation of analog output constant value (totalized analog output type)

Control data format ANALOG=002000 • (2000)

11) Designation of change of mode for preset totalized value output

Control data format

Designation of totalizing value alarm output

AL3, 4=ALARM •

Designation of totalizing value batch output

AL3, 4=BATCH •

Designation of AL3 pulse width at batch output

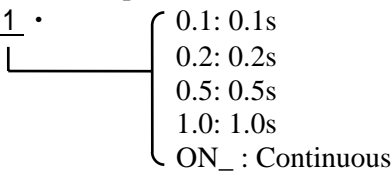
AL3BATCH=0.1 • 

Designation of AL4 pulse width at batch output

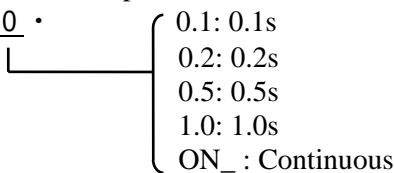
AL4BATCH=1.0 • 

Designation of auto reset at batch output

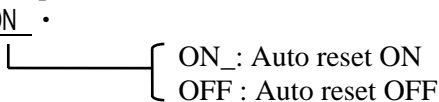
AUTORESET=ON_ • 

12) Designation of preset output set values

Control data format AL1=001000 • (AL1 set value (instantaneous value alarm L))
AL2=020000 • (AL2 set value (instantaneous value alarm H))
AL3=003000 • (AL3 set value (instantaneous value alarm H))
AL4=040000 • (AL4 set value (instantaneous value alarm HH))

13) RESET control

The same work as when there is an input at the reset terminal is available. When the control is done by communication, make the reset terminal open.

Control data format

When RESET is controlled

RESET=ON_ .

When RESET is canceled

RESET=OFF .

14) PAUSE control

The same work as when there is an input at the pause terminal is available. When the control is done by communication, make the pause terminal open.

Control data format

When PAUSE is controlled

PAUSE=ON_ .

When PAUSE is canceled

PAUSE=OFF .

15) LATCH control

The same work as when there is an input at the latch terminal is available. When the control is done by communication, open the latch terminal.

Control data format

When LATCH is controlled

LATCH=ON_ .

When LATCH is cancelled

LATCH=OFF .

Note: __ is space (20H).

3.5 Connection

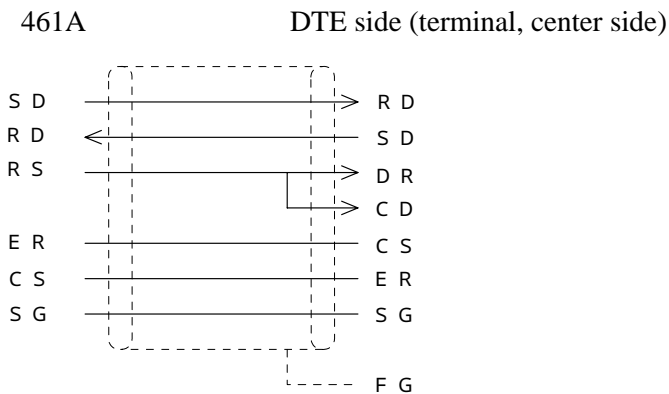

4. RS-232C sample program
N88BASIC (for NEC PC98)

```

1000 '-----
1010 ' 461A RS-232C Sample program
1020 '
1030 ' Copyright 1998 TSURUGA ELECTRIC COPORATION
1040 ' All Righth Reserved
1050 ' Verssion 1.00.00
1060 ' Jan.6 1998
1070 '
1080 ' Conditions of communication      Data length      : 8 bit
1090 '                                Stop bit length   : 1 stop bit
1100 '                                Parity             : None
1110 '                                X parameter        : XON/XOFF
1120 '
1130 ' Profile of transaction:  Communication with 461A is made by cut-in of function key.
1140 '
1150 ' Cut-in of function key
1160 ' F1 key : Receipt of measured data from 461A          (DATA?)
1170 ' F2 key : Change-over of output of totalized value of 461A (DATA=TOTAL__)
1180 ' F3 key : Change-over of output of instantaneous value of 461A (DATA=INSTANT)
1190 ' F4 key : Reset control of 461A                      (RESET=ON_)
1200 ' F5 key : Reset control of 461A                      (RESET=OFF)
1210 ' F6 key : Latch control of 461A                     (LATCH=ON )
1220 ' F7 key : Latch control of 461A                     (LATCH=OFF)
1230 '
1240 '-----
1250 CLS :ON ERROR GOTO *RS232CERR ' Error solution
1260 CONSOLE 0,25,0,1
1270 CLOSE #1
1280 '
1290 OPEN "COM:N81X" AS #1 ' RS-232C mode setting 8BIT P=NONE STOP-BIT1
1300 ON COM GOSUB *RS232CREC :COM ON ' RS-232C cut-in of receiving
1310 PRINT #1,CHR$(&H11); ' X ON
1320 ON KEY GOSUB *F1KEY , *F2KEY , *F3KEY , *F4KEY , *F5KEY , *F6KEY , *F7KEY
1330 LOCATE 0,25
1340 PRINT" F1:DATA F2:TOTAL F3:INSTANT F4:RESET ON ";
1350 PRINT"F5:RESET OFF F6:LATCH ON F7:LATCH OFF"
1360 KEY ON
1370 '
1380 I = 1 : WHILE I = 1 : WEND ' Infinite loop
1390 '
1400 '-----
1410 ' F1 key: Receiving measured data of input A from 461A (DATA?)
1420 '-----
1430 *F1KEY
1440 PRINT #1,"DATA?";:PRINT #1,CHR$(&HD);
1450 RETURN
1460 '
1470 '-----
1480 ' F2 key: Chang-over of data output of totalized value of 461A (DATA=TOTAL__)
1490 '-----
1500 *F2KEY
1510 PRINT #1,"DATA=TOTAL ";:PRINT #1,CHR$(&HD);
1520 RETURN
1530 '
1540 '-----
1550 ' F3 key: Change-over of data output of instantaneous value of 461A (DATA=INSTANT)
1560 '-----
1570 *F3KEY
1580 PRINT #1,"DATA=INSTANT";:PRINT #1,CHR$(&HD);
1590 RETURN
1600 '

```

```

1610 '-----
1620 '   F4 key: Reset control of 461A           (RESET=ON_)
1630 '-----
1640 *F4KEY
1650   PRINT #1,"RESET=ON ";:PRINT #1,CHR$(&HD);
1660   RETURN
1670 '
1680 '-----
1690 '   F5 key: Reset control of 461A           (RESET=OFF)
1700 '-----
1710 *F5KEY
1720   PRINT #1,"RESET=OFF";:PRINT #1,CHR$(&HD);
1730   RETURN
1740 '
1750 '-----
1760 '   F6 key: Latch control of 461A           (LATCH=ON_)
1770 '-----
1780 *F6KEY
1790   PRINT #1,"LATCH=ON ";:PRINT #1,CHR$(&HD);
1800   RETURN
1810 '
1820 '-----
1830 '   F7 key: Latch control of 461A           (LATCH=OFF)
1840 '-----
1850 *F7KEY
1860   PRINT #1,"LATCH=OFF";:PRINT #1,CHR$(&HD);
1870   RETURN
1880 '
1890 '-----
1900 '   Error transaction
1910 '-----
1920 *RS232CERR
1930   CLOSE #1
1940   RESUME
1950 '
1960 '-----
1970 '   Cut-in of receiving
1980 '-----
1990 *RS232CREC
2000   WHILE LOC(#1) <> 0
2010     INPUT #1,D$
2020     LOCATE 20,10:PRINT SPC(20):LOCATE 20,10:PRINT D$
2030     LOCATE 20,11:PRINT SPC(10):LOCATE 20,11:PRINT VAL(D$)
2040   WEND
2050   RETURN
2060 '-----
2070 END

```